

Nibley City Engineering Design Standards



A handwritten signature in blue ink, appearing to read "Tom Dickinson", is positioned above a horizontal blue line.

Tom Dickinson, PE City
Engineer Nibley City

03-23-2023

Updated

The Engineering Design Standards, Construction Standards, Details, and Specifications shall together with all referenced documents and the City Code, govern the design and construction of all public and where appropriate private infrastructure in Nibley City. These standards may be updated periodically and revised as deemed appropriate and necessary. Visit www.nibleycity.com to verify this document is the most current version of the standards.

Mayor
Larry Jacobsen



Council Members
Erin Mann
Kay Sweeten
Nathan Laursen
Norman Larsen
Tom Bernhardt

Nibley City Engineering Design Standards History of Edits

SECTION	ACTION	DATE
Ch. 4 Water Systems	Updated Entire Section	March 2023
Approved Materials List- Water Systems	Updated Entire Section	March 2023
Ch. 5 Sewer Systems	Updated Entire Section	March 2023
Approved Materials List- Sewer Systems	Updated Entire Section	March 2023
APWA Details- Water	Updated All Details	March 2023
APWA Details- Sewer	Updated All Details	March 2023
Cold Weather Paving Standard	Adopted Standard- Amends APWA Cold Weather Paving Standards	March 2023

Tom Dickinson, PE
City Engineer, Nibley City

3/23/2023
Date

TABLE OF CONTENTS

SECTION 0	General Notes
SECTION 1	General Definitions
SECTION 2	Development Standards
SECTION 3	Drawing Standards – Plat & Construction
SECTION 4	Water Systems
SECTION 5	Sewer Systems
SECTION 6	Storm Water Systems
SECTION 7	Other Utility Systems
SECTION 8	Transportation Standards
SECTION 9	Landscape and Irrigation Systems
SECTION 10	Standard Details and Specifications
SECTION 11	Amendments to APWA Standard Specifications
SECTION 12	Construction Inspection and Acceptance Summary
SECTION 13	Bridge Standards
SECTION 14	Secondary Water Systems
SECTION 15	Private Infrastructure Standards
SECTION 16	Standard Details & Modifications to APWA Standard Plans



0.1 General Notes

0.1.1 General Notes for Construction

ALL plans for construction within the Nibley City Shall have the following shown on either the Cover Sheet or the Detail Sheet

NIBLEY CITY GENERAL NOTES FOR CONSTRUCTION

- A. CONTRACTOR SHALL OBTAIN ALL NECESSARY PERMITS PRIOR TO CONSTRUCTION.
- B. ALL CONSTRUCTION SHALL CONFORM TO THE CITY ENGINEERING STANDARDS, CITY STANDARD DETAILS, CURRENT APWA MANUAL OF STANDARD SPECIFICATIONS / STANDARD PLANS, OR OTHER STANDARD APPROVED BY THE CITY ENGINEER IN WRITING.
- C. THIS SET OF PLANS HAS BEEN REVIEWED FOR COMPLIANCE WITH CITY REQUIREMENTS PRIOR TO ISSUANCE OF CONSTRUCTION PERMITS. HOWEVER, SUCH REVIEW SHALL NOT PREVENT THE CITY FROM REQUIRING CORRECTION OF ERRORS IN PLANS FOUND TO BE IN VIOLATION OF ANY LAW OR ORDINANCE.
- D. THE CITY DOES NOT WARRANT ANY QUANTITIES SHOWN ON THESE PLANS.
- E. THE CITY APPROVAL IS FOR GENERAL LAYOUT IN THE RIGHT-OF-WAY ONLY. THIS APPROVAL IS VALID FOR A PERIOD OF ONE YEAR. CONSTRUCTION PERMITS SHALL BE OBTAINED DURING THIS PERIOD OR THE PLANS SHALL BE RESUBMITTED FOR REVIEW AND APPROVAL.
- F. AN APPROVED SET OF PLANS SHALL BE AVAILABLE ON THE JOB SITE AT ALL TIMES.
- G. THE CITY CONSTRUCTION INSPECTOR SHALL BE NOTIFIED **48 HOURS** PRIOR TO ANY CONSTRUCTION WORK AND INSPECTIONS. CONSTRUCTION WORK CONCEALED WITHOUT INSPECTION BY THE CITY CONSTRUCTION INSPECTOR SHALL BE SUBJECT TO EXPOSURE AT THE CONTRACTOR'S EXPENSE.
- H. ANY WORK PERFORMED WITHOUT THE APPROVAL OF THE CITY ENGINEER, OR DESIGNEE, AND ANY WORK/MATERIAL NOT IN CONFORMANCE WITH CITY ENGINEERING STANDARDS IS SUBJECT TO REMOVAL AND REPLACEMENT AT THE CONTRACTOR'S EXPENSE.
- I. THE DEVELOPER IS RESPONSIBLE FOR THE REMOVAL OR RELOCATION OF ALL OBSTRUCTIONS WITHIN THE RIGHT-OF-WAY PRIOR TO STARTING NEW CONSTRUCTION.
- J. THE DEVELOPER IS RESPONSIBLE FOR ARRANGING THE RELOCATION AND ASSOCIATED COSTS OF ALL UTILITIES. A UTILITY RELOCATION



SCHEDULE SHALL BE SUBMITTED PRIOR TO THE ISSUANCE OF PERMITS.

- K. THE DEVELOPER IS RESPONSIBLE FOR OBTAINING OR DEDICATING ALL REQUIRED RIGHTS-OF-WAY AND EASEMENTS TO THE CITY PRIOR TO ISSUANCE OF PERMITS.
- L. THE CONTRACTOR SHALL CONTACT BLUE STAKE PRIOR TO CONSTRUCTION ACCORDING TO BLUE STAKE STANDARD NOTIFICATION TIMEFRAMES. THE CONTRACTOR SHALL LOCATE ALL CONFLICTS PRIOR TO CONSTRUCTION.
- M. THE CONTRACTOR SHALL BARRICADE CONSTRUCTION SITES AT ALL TIMES PER THE MUTCD. A TRAFFIC CONTROL PLAN SHALL BE SUBMITTED TO THE CITY FOR APPROVAL IN ADVANCE OF CONSTRUCTION.
- N. THE UNLAWFUL REMOVAL OF WATER FROM A CITY FIRE HYDRANT OR ANY OTHER SOURCE IS A VIOLATION OF THE MUNICIPAL CODE. CONTACT THE CITY INSPECTOR FOR SETTING UP USE.
- O. THE CONTRACTOR SHALL COMPLY WITH THE ENVIRONMENTAL PROTECTION AGENCY NATIONAL POLLUTION DISCHARGE ELIMINATION SYSTEM (NPDES) STORM WATER REQUIREMENTS ESTABLISHED FOR CONSTRUCTION SITES, DEQ GENERAL PERMIT FOR DISCHARGE FROM CONSTRUCTION ACTIVITIES, AND THE NIBLEY CITY STORM WATER MANAGEMENT PLAN.
- P. THESE PLANS REFLECT CONDITIONS AS THEY EXIST AT THE TIME OF DESIGN. IF EXISTING CONDITIONS HAVE CHANGED BY THE TIME OF CONSTRUCTION THE CONTRACTOR SHALL NOTIFY THE CITY AND THESE PLANS MAY HAVE TO BE AMENDED PRIOR TO PROCEEDING WITH CONSTRUCTION ACTIVITIES.
- Q. "AS-BUILT" DRAWINGS (ONE SET OF PRINTS AND AN ELECTRONIC PDF COPY), CERTIFIED BY THE DEVELOPER'S ENGINEER, SHALL BE SUBMITTED AND APPROVED PRIOR TO ISSUANCE OF A BUILDING CERTIFICATE OF OCCUPANCY AND ACCEPTANCE OF IMPROVEMENTS BY THE CITY. (SEE THE CITY CODE FOR AS-BUILT REQUIREMENTS)

0.1.2 General Notes for Grading and Drainage Construction

All plans for on-site Grading and Drainage construction shall have the following shown on either the Cover Sheet or the Detail Sheet.

NIBLEY CITY GENERAL NOTES FOR GRADING AND DRAINAGE CONSTRUCTION

- A. ALL GENERAL CONSTRUCTION NOTES SHALL APPLY



-
- B. UNLESS SPECIFIC FINISHED FLOOR ELEVATIONS ARE SHOWN ON THE PLAT, ELEVATIONS SHALL BE A MINIMUM 6 INCHES ABOVE THE HIGHEST ADJACENT TOP OF CURB OR STREET CENTERLINE WHICH EVER IS HIGHER OR 12 INCHES ABOVE THE HISTORIC GROUNDWATER ELEVATIONS AS CERTIFIED BY A GEOTECHNICAL ENGINEER AND SPECIFICALLY IDENTIFIED FOR EACH LOT ON THE RECORDED FINAL PLAT.
 - C. A PERMIT IS REQUIRED FOR ANY SITE GRADING.
 - D. STAKING PAD AND/OR FINISHED FLOOR ELEVATIONS ARE THE RESPONSIBILITY OF THE DEVELOPER OR HIS ENGINEER. FOR LOTS IN FEMA ZONES A, AO, AH, A1-A33, AND A99, THE FINISHED BUILDING FLOOR OR STEM WALL ELEVATION SHALL BE SUBMITTED AND APPROVED PRIOR TO ANY VERTICAL CONSTRUCTION.
 - E. THE CONTRACTOR SHALL COMPLY WITH THE APPROVED STORM WATER POLLUTION PREVENTION PLAN PREPARED IN ACCORDANCE WITH THE CITY'S GENERAL UPDES STORM WATER PERMIT REQUIREMENTS.
 - F. THE GRADING CONTRACTOR SHALL DESIGNATE THE LOCATION FOR WASTING SPOIL MATERIALS AND OBTAIN A LETTER FROM THE OWNER GIVING PERMISSION FOR SAID DISPOSAL PRIOR TO STARTING ON-SITE CONSTRUCTION.
 - G. GRADING AND DRAINAGE PLAN APPROVAL INCLUDES RETENTION AND DETENTION AREAS, OTHER DRAINAGE FACILITIES AND CHANGES TO SURFACE GRADING AND STORMWATER FACILITIES AFFECTING DRAINAGE STRUCTURES, CURBS, ASPHALT PAVEMENT, AND BUILDING FLOOR ELEVATIONS.
 - H. THE CONTRACTOR SHALL PROVIDE ALL RETENTION AND DETENTION BASINS AT ELEVATIONS AS SHOWN ON THE PLANS. RETENTION BASINS SIDE SLOPES SHALL NOT EXCEED 3:1. RETENTION BASIN HIGH WATER ELEVATIONS SHALL NOT EXCEED 3-FOOT AND SHALL BE SET 12 INCHES ABOVE THE HISTORIC GROUNDWATER LEVEL. RETENTION IS NOT PERMITTED WITHIN PUBLIC RIGHTS-OF-WAY OR PUBLIC UTILITY EASEMENTS.
 - I. THE CONTRACTOR IS RESPONSIBLE FOR LOCATING AND CONFIRMING DEPTHS OF ALL THE EXISTING UTILITY LINES WITHIN PROPOSED RETENTION BASIN AREAS. IF THE BASIN CANNOT BE CONSTRUCTED PER PLAN AS A RESULT OF CONFLICT WITH UNDERGROUND UTILITIES, THE CONTRACTOR SHOULD CONTACT THE CITY AND DESIGNER AND REQUEST MODIFICATION OF THE BASIN DESIGN.



0.1.3 General Notes for BMP Plan, Small Sites

All BMP Plans for Small Sites shall have the following notes shown on the BMP plan sheet or BMP detail sheet.

NIBLEY CITY
GENERAL NOTES FOR SWPP PLAN

- A. ALL GENERAL CONSTRUCTION NOTES SHALL APPLY.
- B. APPROVAL OF THIS DOCUMENT INDICATES THAT NIBLEY CITY HAS REVIEWED AND FOUND THIS TO BE IN GENERAL COMPLIANCE WITH THE CITY'S STORMWATER MANAGEMENT PLAN. NIBLEY CITY IS AT NO TIME RESPONSIBLE FOR THE APPLICANT'S/OPERATOR'S DUTIES TO COMPLY WITH ANY FEDERAL, STATE, OR LOCAL LAW OR ORDINANCE.
- C. THE FACILITIES SHOWN ON THIS PLAN SHALL BE CONSTRUCTED IN CONJUNCTION WITH ALL CLEARING AND GRADING ACTIVITIES IN SUCH A MANNER AS TO ENSURE THAT SEDIMENT-LADEN WATER DOES NOT ENTER THE DRAINAGE SYSTEM OR VIOLATE APPLICABLE WATER STANDARDS. ADDITIONALLY, THEY SHALL BE INSTALLED AND IN OPERATION PRIOR TO ANY GRADING OR LAND CLEARING. WHEREVER POSSIBLE, NATURAL VEGETATION SHALL BE MAINTAINED TO ASSIST IN SILT CONTROL.
- D. CONSTRUCTION SHALL BE PERFORMED IN SUCH A MANNER SO THAT STORMWATER DISCHARGES DO NOT CAUSE ANY FLOODING OR DAMAGE TO ADJACENT PROPERTIES OR FLOWS OF SEDIMENT ONTO PUBLIC STREETS, SIDEWALKS, DRAINAGE CHANNELS, PUBLIC UTILITY EASEMENTS OR RIGHTS-OF-WAYS.
- E. FACILITIES SHALL BE MAINTAINED AS NECESSARY TO ENSURE THEIR CONTINUED FUNCTIONALITY. IN ADDITION, ALL CONTROLS SHALL BE MAINTAINED IN SATISFACTORY CONDITION UNTIL SUCH TIME THAT CONSTRUCTION IS COMPLETED, PERMANENT DRAINAGE FACILITIES ARE OPERATIONAL, AND THE POTENTIAL FOR EROSION HAS PASSED.
- F. THE PLANS SHALL BE AMENDED AS NECESSARY DURING THE COURSE OF CONSTRUCTION TO RESOLVE ANY PROBLEM AREAS, WHICH BECOME EVIDENT DURING CONSTRUCTION, ROUTINE INSPECTIONS, AND/OR PERIODS OF RAINFALL. IF IT IS DETERMINED THAT CURRENT CONTROLS ARE NOT EFFECTIVE AT MINIMIZING POLLUTANT DISCHARGES FROM THE SITE, IMMEDIATE EFFORTS SHALL BE MADE TO CORRECT THE PROBLEM WITHIN 72 HOURS AND/OR PRIOR TO THE



NEXT RAIN EVENT. THE AMENDED PLAN SHALL BE MAINTAINED ON-SITE.

- G. IF AT ANY TIME, THIS SITE BECOMES IMPACTED BY OTHER CONSTRUCTION, STORMWATER POLLUTION PREVENTION ACTIVITIES SHALL BE COORDINATED BETWEEN THE SITES AND DOCUMENTED ON THE PLANS.
- H. PROPERTY THROUGH WHICH A WATERCOURSE PASSES SHALL BE KEPT FREE OF CONSTRUCTION MATERIALS, TRASH, DEBRIS, EXCESSIVE VEGETATION, AND OTHER OBSTACLES OR SUBSTANCES WHICH WOULD POLLUTE, CONTAMINATE, OR SIGNIFICANTLY RETARD OR DIVERT THE FLOW OF STORMWATER THROUGH THE PROPERTY.
- I. THE SITE SHALL AT ALL TIMES REMAIN FREE OF LOOSE TRASH AND DEBRIS. APPROPRIATELY SIZED COVERED WASTE RECEPTACLES SHALL BE PROVIDED ONSITE AND STORED A MINIMUM OF 50 FEET FROM ANY DRAINAGEWAY OR DRAINAGE INLET.
- J. A COPY OF THE APPROVED STORM WATER POLLUTION PREVENTION PLAN (SWPPP), NOTICE OF INTENT (NOI) AND ALL RELATED RECORDS SHALL BE MAINTAINED ON THE SITE AND AVAILABLE FOR REVIEW UPON REQUEST. NIBLEY CITY MAY AT ANY TIME PERFORM A COMPLIANCE INSPECTION OF THE SITE.

0.1.4 General Notes for Water Main Construction

All plans for water main construction within right-of-way or easements shall have the following shown on either the Cover Sheet or the Detail Sheet.

NIBLEY CITY GENERAL NOTES FOR WATER MAIN CONSTRUCTION

- A. ALL GENERAL CONSTRUCTION NOTES SHALL APPLY.
- B. ALL CONSTRUCTION SHALL CONFORM TO THE CITY ENGINEERING STANDARDS, CITY STANDARD DETAILS, AND CURRENT APWA MANUAL OF STANDARD SPECIFICATIONS AND STANDARD PLANS.
- C. NIBLEY CITY INSPECTORS SHALL BE NOTIFIED **48-HOURS** PRIOR TO STARTING EACH PHASE OF CONSTRUCTION, AND EACH INSPECTION REQUESTED.
- D. THE CONTRACTOR SHALL BE RESPONSIBLE FOR VERIFYING THE LOCATION AND ELEVATION OF ANY UTILITY LINES BEFORE STARTING CONSTRUCTION. IF THE EXISTING LINE IS FOUND TO BE IN A SUBSTANTIALLY DIFFERENT LOCATION, OR WILL ADVERSELY AFFECT THE OPERATION OF THE UTILITY, THE CONTRACTOR SHALL NOTIFY THE NIBLEY CITY PRIOR TO MAKING THE CONNECTIONS. AMENDMENTS TO



THE PLANS MAY BE REQUIRED PRIOR TO PROCEEDING WITH CONSTRUCTION ACTIVITIES.

- E. THE NIBLEY CITY IS NOT LIABLE FOR DELAYS OR DAMAGES TO UTILITIES RELATED TO THIS CONSTRUCTION.
- F. BACKFILLING SHALL NOT BE DONE UNTIL LINES ARE INSPECTED AND APPROVED BY THE CITY CONSTRUCTION INSPECTOR.
- G. MATERIALS SHALL BE FURNISHED AND INSTALLED BY THE CONTRACTOR ACCORDING TO THE CITY'S APPROVED MATERIALS LIST, ENGINEERING STANDARDS CITY STANDARD DETAILS AND APWA MANUAL OF STANDARD SPECIFICATIONS AND STANDARD PLANS. THE APPROVED MATERIALS LIST IS AVAILABLE ON THE CITY WEBSITE.
- H. THE MINIMUM SIZE WATER SERVICE SHALL BE ONE INCH. SERVICE LINES SHALL BE CONTINUOUS UNDER PAVEMENT WITHOUT A CONNECTION OR EXTENSION.
- I. ALL TAPS SHALL USE ALL BRONZE OR STAINLESS-STEEL DOUBLE STRAP SERVICE SADDLES.
- J. THE DEVELOPER IS TO INSTALL ALL TAPS AND METER CANS. THE TAP SHALL TERMINATE WITH WATER METER SETTER WITHIN THE METER CAN PER CITY STANDARDS.
- K. METERS SHALL BE FURNISHED AND INSTALLED BY THE UTILITY AGENCY AFTER PAYMENT OF ALL PREVAILING FEES.
- L. METERS WILL ONLY BE INSTALLED IF:
 - 1. ALL BACTERIOLOGICAL TESTS HAVE BEEN RECEIVED.
 - 2. CURB AND GUTTER HAS BEEN CONSTRUCTED AND THE METER CAN IS INSTALLED TO THE SPECIFIED GRADE PER PLANS.
 - 3. THE METER CAN IS VISIBLE AND FREE OF OBSTRUCTION AND DAMAGE.
 - 4. THE METER CAN AND LID ARE PER THE CITY APPROVED MATERIALS LIST.
 - 5. THE METER CAN AND LID ARE OF THE CORRECT SIZE.
 - 6. THE WATER SERVICE LINES AND CONNECTIONS ARE FREE OF LEAKS.
- M. PAVEMENT REPLACEMENTS SHALL BE MADE PER THE CITY ENGINEERING STANDARDS, CITY STANDARD DETAILS, AND APWA MANUAL OF STANDARD SPECIFICATIONS AND STANDARD PLANS.
- N. ALL WATER SERVICE CONNECTIONS SHALL BE EXTENDED A SUFFICIENT DISTANCE ACROSS THE RIGHT-OF-WAY TO CLEAR ALL FACILITIES TO BE INSTALLED IN PUBLIC UTILITY EASEMENTS PARALLELING STREET RIGHT-OF-WAY.
- O. TRACER WIRE AND LOCATING TAPE SHALL BE INSTALLED ON ALL WATER LINES LARGER THAN 6 INCHES. LOCATING TAPE SHALL BE PLACED ONE FOOT ABOVE THE MAIN.



-
- P. TRACER WIRE SHALL BE BROUGHT UP ALL VALVE CANS AND FIRE HYDRANTS. WIRE SHALL BE THREADED THROUGH TO THE INSIDE OF THE VALVE CAN BY MEANS OF A HOLE IN THE CAN.
 - Q. PRIVATE ON-SITE WATER AND SEWER LINES SHALL BE CONSTRUCTED IN ACCORDANCE WITH ALL APPLICABLE CITY STANDARDS.
 - R. THE CONTRACTOR MUST REQUEST A TEMPORARY METER FOR FILLING AND TESTING OF NEW WATER LINES FROM THE CITY CONSTRUCTION INSPECTOR. THIS METER SHOULD BE ORDERED TWO WORKING DAYS PRIOR TO THE START OF CONSTRUCTION.

0.1.5 General Notes for Sewer Main Construction

All plans for sewer main construction within right-of-way or easements shall have the following shown on either the Cover Sheet or the Detail Sheet.

NIBLEY CITY GENERAL NOTES FOR SEWER MAIN CONSTRUCTION

- A. ALL GENERAL CONSTRUCTION NOTES SHALL APPLY.
- B. CONTRACTOR WILL EXPOSE ANY LINES BEING TIED INTO, TO VERIFY LOCATION.
- C. THE CITY IS NOT LIABLE FOR DELAYS OR DAMAGES TO UTILITIES RELATED TO THIS CONSTRUCTION.
- D. BACKFILLING SHALL NOT BE DONE UNTIL LINES ARE INSPECTED AND APPROVED BY THE CITY CONSTRUCTION INSPECTOR.
- E. PAVEMENT REPLACEMENTS SHALL BE MADE PER THE CITY ENGINEERING STANDARDS, CITY STANDARD DETAILS, AND APWA MANUAL OF STANDARD SPECIFICATIONS AND STANDARD PLANS.
- F. SHORT TERM DEFLECTION TESTING SHALL BE PERFORMED ON THE TOTAL FOOTAGE OF INSTALLED PIPE, AFTER COMPLETE BACKFILL AND COMPACTION, BUT PRIOR TO THE INSTALLATION OF FINISHED SURFACE MATERIAL. ADDITIONAL TESTING MAY BE REQUIRED. A SHORT-TERM DEFLECTION IN EXCESS OF FIVE PERCENT SHALL BE CONSIDERED UNSERVICEABLE AND SHALL BE REPAIRED OR REPLACED AND RETESTED.
- G. A VISUAL INSPECTION OF THE INTERIOR OF THE SEWER LINE USING A TELEVISION CAMERA WILL BE PERFORMED ON THE TOTAL FOOTAGE OF ALL SEWER LINES, AFTER COMPLETE BACKFILL AND COMPACTION, BUT PRIOR TO THE INSTALLATION OF FINISHED SURFACE MATERIAL. ANY PORTION CONSIDERED UNSERVICEABLE BY THE CITY SHALL BE REPAIRED OR REPLACED AND RETESTED AT NO ADDITIONAL COST TO THE CITY. A COPY OF THE SEWER LINE VIDEO SHALL BE PROVIDED ON A FLASH DRIVE ALONG WITH A REPORT OF OBSERVATIONS. ALL



EXPENSES FOR VISUAL INSPECTION USING TELEVISION CAMERA IS THE RESPONSIBILITY OF THE CONTRACTOR.

- H. ALL TAPS SHALL BE WYE TYPE.
- I. SEWER TAPS MUST BE A MINIMUM OF 4 FEET DEEP AT PROPERTY LINES.
- J. ALL SEWER SERVICE CONNECTIONS SHALL BE EXTENDED A SUFFICIENT DISTANCE ACROSS RIGHT-OF-WAY TO CLEAR ALL FACILITIES TO BE INSTALLED IN PUBLIC UTILITY EASEMENTS PARALLELING THE RIGHT-OF-WAY.
- K. TRACER WIRE AND CAUTION TAPE SHALL BE INSTALLED ON ALL PVC SEWER LINES. TRACER WIRE SHALL BE THREADED THROUGH TO THE INSIDE OF THE MANHOLE BY MEANS OF A HOLE IN THE CONE.
- L. ALL SANITARY SEWER MANHOLES SHALL BE TESTED IN ACCORDANCE WITH ASTM C-1244-93 .
- M. PRIVATE ON-SITE WATER AND SEWER LINES SHALL BE CONSTRUCTED IN ACCORDANCE WITH ALL APPLICABLE CITY STANDARDS.

0.1.6 General Notes for Secondary Water Main Construction

All plans for secondary water main construction within right-of-way or easements shall have the following shown on either the Cover Sheet or the Detail Sheet.

NIBLEY CITY

GENERAL NOTES FOR SECONDARY WATER MAIN CONSTRUCTION

- A. THE NIBLEY CITY ENGINEERING DEPARTMENT (OR ITS AUTHORIZED REPRESENTATIVE) SHALL INSPECT AND APPROVE ALL TRENCHING, BEDDING, PIPE INSTALLATION, BACKFILL AND COMPACTION. NIBLEY CITY SHALL INSPECT AND APPROVE ALL PRESSURE TESTING, DISINFECTIONS, AND ALL OPERATIONAL SYSTEMS TESTS. AFTER COMPLETION OF EACH PHASE OF THE SECONDARY WATER SYSTEM, BUT BEFORE ACCEPTANCE BY NIBLEY CITY AND THE WARRANTY PERIOD, ALL PUNCH LIST ITEMS SHALL BE 100 % COMPLETED, AS GENERATED BY THE NIBLEY CITY.
- B. THE MINIMUM COVER OVER SECONDARY WATER MAINS IS 48 INCHES.
- C. BACKFILLING SHALL NOT BE DONE UNTIL MAINS ARE INSPECTED AND APPROVED BY THE CITY CONSTRUCTION INSPECTOR.
- D. PAVEMENT REPLACEMENTS SHALL BE MADE PER THE NIBLEY CITY ENGINEERING STANDARDS, AND APWA MANUAL OF STANDARD SPECIFICATIONS AND STANDARD PLANS.



-
- E. ANY CHANGES FROM APPROVED PLANS SHALL BE SUBMITTED TO NIBLEY CITY FOR WRITTEN APPROVAL PRIOR TO INSTALLATION.
 - F. AN APPROVED METALLIC MARKING TAPE SHALL BE PLACED ABOVE THE INSTALLED SECONDARY WATER MAIN AND SHALL HAVE THE WORDS “CAUTION: SECONDARY WATER – DO NOT DRINK”.
 - G. ALL SECONDARY WATER VALVE COVERS SHALL BE SQUARE AND IDENTIFIED AS “SECONDARY WATER”.
 - H. A 2-INCH x 4-INCH METAL STUD (PAINTED PURPLE) SHALL BE SET ONE-FOOT BEHIND EACH SECONDARY WATER STUB-OUT.
 - I. ALL SECONDARY WATER LINES SHALL BE PURPLE IN COLOR OR CONSTRUCTED WITH A PURPLE POLYETHYLENE WRAP.
 - J. TRACER WIRE SHALL BE INSTALLED ON ALL LINES.

0.1.7 General Notes for Street Construction

All plans for street construction within right-of-way or easements shall have the following shown on either the Cover Sheet or the Detail Sheet.

NIBLEY CITY GENERAL NOTES FOR STREET CONSTRUCTION

- A. ALL GENERAL CONSTRUCTION NOTES SHALL APPLY.
- B. CONTRACTOR SHALL CONTINUOUSLY REFERENCE LOCATION OF ALL VALVES DURING CONSTRUCTION.
- C. ALL UNDERGROUND UTILITIES LOCATED IN THE ROADWAY SHALL BE COMPLETED BEFORE PAVING.
- D. BASE COURSE SHALL NOT BE PLACED UNTIL SUBGRADE HAS BEEN APPROVED BY THE CITY CONSTRUCTION INSPECTOR.
- E. GUTTERS SHALL BE WATER TESTED FOR DRAINAGE IN THE PRESENCE OF THE CITY CONSTRUCTION INSPECTOR.
- F. THE EXACT POINT OF MATCHING TERMINATION AND OVERLAY SHALL BE DETERMINED IN THE FIELD BY THE CITY CONSTRUCTION INSPECTOR.
- G. CURB, GUTTER, SIDEWALK, AND PAVEMENT SHALL BE SWEEPED CLEAN OF DIRT AND DEBRIS.
- H. ANY SAW CUT ALONG EXISTING ROADWAY EDGE WHICH REMOVES THE EDGE OF THE ROADWAY SHALL BE A MINIMUM OF THREE-FOOT FROM THE EDGE OF THE EXISTING ROADWAY. THE CUT DISTANCE MAY BE GREATER, BASED ON PAVEMENT CONDITIONS OR ROADWAY



ELEVATIONS BUT SHALL NOT BE LOCATED WITHIN A LANE WHEEL PATH, AND IF NEEDED SHALL BE IN HALF LANE INCREMENTS.

- I. ALL PAVEMENT MARKING, SIGNING AND CONSTRUCTION SHALL CONFORM TO THE MANUAL ON UNIFORM TRAFFIC CONTROL DEVICES (MUTCD), THE NIBLEY CITY ENGINEERING STANDARDS AND APWA STANDARD SPECIFICATION AND STANDARD PLANS.
- J. NIBLEY CITY DEFERS TO APWA SPECIFICATION REGARDING ENVIRONMENTAL CONDITIONS FOR PAVING (WITH TEMPERATURE BEING OF SPECIFIC NOTE). REFER TO THE CITY'S COLD WEATHER PAVING STANDARD FOR INFORMATION ON PAVING IN TEMPERATURES COOLER THAN THAT ALLOWED BY APWA.

0.1.8 General Notes for Signing and Striping

All plans for Signing and Striping shall have the following shown on either the Cover Sheet or the Detail Sheet.

NIBLEY CITY GENERAL NOTES FOR SIGNING AND STRIPING

- A. ALL GENERAL CONSTRUCTION NOTES SHALL APPLY.
- B. ALL PAVEMENT TEMPORARY AND FINAL MARKING, SIGNING AND CONSTRUCTION SHALL CONFORM TO MANUAL ON UNIFORM TRAFFIC CONTROL DEVICES (MUTCD), THE NIBLEY CITY ENGINEERING STANDARDS AND PLANS, AND THE APWA MANUAL OF STANDARD SPECIFICATION AND PLANS.
- C. SIGNS SHALL BE INSTALLED ON POSTS AS LISTED IN THE CITY'S STREETS APPROVED MATERIALS LIST.
- D. ALL SIGNS THAT ARE REMOVED AND NOT REINSTALLED SHALL BE SALVAGED AND DELIVERED TO THE NIBLEY CITY PUBLIC WORKS DEPARTMENT.
- E. ALL PAVEMENT SUBJECT TO A WARRANTY PERIOD (TYPICALLY ONE YEAR) WILL BE REQUIRED TO PROVIDE NEW THERMOPLASTIC MARKINGS AS A PART OF THE (END OF) WARRANTY INSPECTION.
- F. ALL PAVEMENT MARKINGS ARE TO BE MAINTAINED BY THE DEVELOPER DURING THE WARRANTY PERIOD.
- G. ALL STRIPING SHALL BE 0.015" (15MIL) REFLECTORIZED TRAFFIC PAINT OR 60MIL THERMOPLASTIC.
- H. ALL EXISTING PAVEMENT MARKINGS WHICH CONFLICT WITH PROPOSED MARKINGS SHALL BE REMOVED BY WATERBLASTING, OR BY OTHER CITY APPROVED METHOD (APPROVAL SHALL BE RECEIVED IN WRITING FROM THE CITY ENGINEER), PRIOR TO THE INSTALLATION



OF NEW PAVEMENT MARKINGS. REMOVALS SHALL BE TO THE SATISFACTION OF THE CITY CONSTRUCTION INSPECTOR.

- I. ALL SIGNS SHALL BE OF A MATERIAL AS LISTED IN THE CITY'S STREETS APPROVED MATERIALS LIST AND SHALL BE ATTACHED TO THE STANDARD SIGNAGE ALUMINUM PLATES. SIGN IMAGING SHALL BE IN COMPLIANCE WITH THE REFLECTIVE SHEETING MANUFACTURER'S MATCHED COMPONENT SYSTEM. SIGN IMAGING SHALL CONSIST OF AN ACRYLIC BASED ELECTRONIC CUTTABLE FILM WITH STANDARD HIGHWAY COLORS AS IDENTIFIED IN THE STREETS APPROVED MATERIALS LIST. IN ADDITION, IF CALLED OUT ON THE APPROVED PLANS TO CREATE A GRAFFITI-PROTECTIVE COATING, A PROTECTIVE OVERLAY FILM AS IDENTIFIED IN THE STREETS APPROVED MATERIALS LIST SHALL BE USED WHICH IS DESIGNATED TO COMPLY WITH THE UNDERLYING REFLECTIVE SHEETING MATCHED COMPONENT SYSTEM.
- J. THE CONTRACTOR SHALL SPOT LAYOUT THE ENTIRE PROJECT PRIOR TO STRIPING. THE CONTRACTOR SHALL CONTACT THE CITY CONSTRUCTION INSPECTOR TO MAKE ARRANGEMENTS FOR INSPECTION PRIOR TO APPLYING PAVEMENT MARKINGS. THE PERMANENT PAVEMENT MARKING PLANS SHALL BE MODIFIED WHEN DIRECTED BY THE DESIGN ENGINEER. ANY STRIPING APPLIED BEFORE LAYOUT APPROVAL SHALL BE SUBJECT TO REMOVAL, PAVEMENT RESURFACING, AND RESTRIPIING AT THE CONTRACTOR'S EXPENSE.

0.1.9 General Notes for Landscaping

All plans for Landscaping shall have the following shown on either the Cover Sheet or the Detail Sheet.

NIBLEY CITY GENERAL NOTES FOR LANDSCAPING

- A. ALL GENERAL CONSTRUCTION NOTES SHALL APPLY.
- B. ALL SIGNS, MONUMENT WALLS AND SITE LIGHTING REQUIRE SEPARATE BUILDING APPROVAL.
- C. ALL FIRE HYDRANTS SHALL REQUIRE A 7-FOOT CLEARANCE IN ALL DIRECTIONS TO ANY NEW OR EXISTING LANDSCAPE.
- D. SUBSTITUTIONS IN TYPE, AND/OR DEVIATIONS IN SIZE OR QUANTITY FROM THE APPROVED LANDSCAPE OR IRRIGATION PLANS SHALL NOT BE PERMITTED WITHOUT PRIOR WRITTEN APPROVAL FROM THE NIBLEY CITY. (CONTACT THE NIBLEY CITY ENGINEER REGARDING ALL PLANTING AND IRRIGATION SUBSTITUTIONS.)



-
- E. PLANT LEGEND PROVIDED FOR CONTRACTOR'S CONVENIENCE. CONSTRUCTION PLANS TAKE PRECEDENCE.
 - F. ALL EXISTING LANDSCAPE AND IRRIGATION SYSTEMS THAT ARE DESIGNATED TO REMAIN ON THE APPROVED LANDSCAPE PLANS SHALL NOT BE DAMAGED OR DESTROYED DURING CONSTRUCTION. ANY DAMAGE THAT DOES OCCUR DURING CONSTRUCTION SHALL BE REPLACED IN KIND BY THE CONTRACTOR.
 - G. SIDEWALK AND PAVING CONSTRUCTION THAT ARE PART OF THE LANDSCAPE IMPROVEMENTS SHALL BE IN COMPLIANCE WITH ALL ON-SITE PAVING AND SHALL MEET DESIGN AND CONSTRUCTION REQUIREMENTS OF THE AMERICANS WITH DISABILITIES ACT (ADA).
 - H. PRIOR TO ACCEPTANCE OF ANY BACKFLOW DEVICE, EACH DEVICE SHALL BE TESTED BY A STATE CERTIFIED TESTER AND THE RESULTS PROVIDED TO THE CITY.

All plans for Commercial or Residential development shall have the following shown on the Cover Sheet.

- I. LANDSCAPED AREAS THAT WILL BE MAINTAINED BY CITY PARKS SHALL BE CLEARLY IDENTIFIED ON THESE PLANS AND ARE SUBJECT TO THE FOLLOWING REQUIREMENTS.
 - 1. THE DEVELOPER SHALL MAINTAIN AND WARRANTY ALL PLANTED AREAS INCLUDING IRRIGATION SYSTEMS FOR A PERIOD OF ONE YEAR BEGINNING IMMEDIATELY AFTER THE CITY ISSUES THE NOTIFICATION OF APPROVAL FOR THE PROJECT.
 - 2. DURING THE MAINTENANCE AND WARRANTY PERIOD, THE DEVELOPER SHALL BE RESPONSIBLE FOR MAINTAINING ADEQUATE PROTECTION TO ALL AREAS. ANY DAMAGED PLANTINGS AND OR IRRIGATION SYSTEMS SHALL BE IMMEDIATELY REPAIRED OR REPLACED AT THE DEVELOPER'S EXPENSE.
 - 3. MAINTENANCE SHALL INCLUDE CONTINUOUS OPERATIONS OF WATERING, WEEDING, REMOVAL OF DEAD PLANT MATERIAL, MOWING , ROLLING, FERTILIZING, SPRAYING, INSECT AND PEST CONTROL, RE-SEEDING, REPLACEMENT, AND ALL OTHER MEASURES NECESSARY TO ENSURE GOOD NORMAL GROWTH.
 - 4. WHEN THE TURF HAS ESTABLISHED SUFFICIENT ROOT STRUCTURE AND AN APPROXIMATE HEIGHT OF 3 INCHES, MOWING SHALL BEGIN IMMEDIATELY AND REDUCE IN SAFE INCREMENTS TO A HEIGHT OF 2 INCHES AND SHALL BE MAINTAINED THEREAFTER AT THE HEIGHT OF 2 INCHES.
 - 5. AT THE TERMINATION OF THE MAINTENANCE AND WARRANTY PERIOD, ALL TURF AREAS SHALL BE LIVE, HEALTHY, UNDAMAGED,



-
- AND FREE OF INFESTATIONS. ALL AREAS SHALL BE COMPLETELY VOID OF BARREN SPOTS LARGER THAN 3 INCHES BY 3 INCHES.
6. IF ALL PLANTINGS ARE NOT ACCEPTABLE AT THE END OF THE ONE YEAR PERIOD, THE MAINTENANCE AND WARRANTY PERIOD SHALL CONTINUE UNTIL ALL UNACCEPTABLE PLANTINGS ARE REPLACED OR REPAIRED AND THE LANDSCAPING MEETS CITY APPROVAL.
 7. AREAS MAY INCLUDE RETENTION BASINS, PARKS, RIGHTS-OF-WAY, AND STREET CENTER MEDIAN LANDSCAPING.

0.1.10 General Notes for Final Plat

All Final Plats shall have the following general notes shown on either the Cover Sheet or the Detail Sheet, unless otherwise approved by the City Engineering and Community Development Departments.

NIBLEY CITY GENERAL NOTES FOR FINAL PLAT

- A. NO STRUCTURES OF ANY KIND SHALL BE CONSTRUCTED OR PLACED WITHIN OR OVER A PUBLIC UTILITY EASEMENT EXCEPT: UTILITIES, ASPHALT PAVING, GRASS, AND WOOD, WIRE OR REMOVABLE SECTION TYPE FENCING. NIBLEY CITY SHALL NOT BE REQUIRED TO REPLACE OR PROVIDE REIMBURSEMENT FOR THE COST OF REPLACING ANY OBSTRUCTIONS, PAVING OR PLANTING THAT IS REMOVED DURING THE COURSE OF MAINTAINING, CONSTRUCTING OR RECONSTRUCTING UTILITY FACILITIES.
- B. NO STRUCTURE OF ANY KIND SHALL BE CONSTRUCTED OR ANY VEGETATION SHALL BE PLANTED NOR WILL BE ALLOWED TO GROW WITHIN, ON OR OVER ANY DRAINAGE EASEMENT WHICH WOULD OBSTRUCT OR DIVERT THE FLOW OF STORM WATER. THE CITY MAY, IF IT SO DESIRES, CONSTRUCT OR MAINTAIN DRAINAGE FACILITIES ON OR UNDER THE LAND OF THE DRAINAGE EASEMENT.
- C. IMPROVEMENTS MADE WITHIN A CITY RIGHT-OF-WAY, TRACT, OR EASEMENT THAT WILL BE MAINTAINED IN THE FUTURE BY NIBLEY CITY SHALL BE CLEARLY IDENTIFIED ON THE APPROVED PLANS AND ARE SUBJECT TO THE FOLLOWING REQUIREMENTS. IMPROVEMENTS MAY INCLUDE BUT ARE NOT LIMITED TO STREET SURFACES, CURBS, GUTTERS, SIDEWALKS, RAMPS, DRIVEWAYS, TURN BAYS, BUS BAYS, STREET LIGHTING, SIGNAGE, AND STREET STRIPING.
 1. THE DEVELOPER SHALL MAINTAIN AND WARRANTY ALL IMPROVEMENTS FOR A PERIOD OF ONE YEAR BEGINNING IMMEDIATELY AFTER THE CITY ISSUES THE NOTIFICATION OF APPROVAL FOR THE PROJECT.



-
2. DURING THE MAINTENANCE AND WARRANTY PERIOD, THE DEVELOPER SHALL BE RESPONSIBLE FOR MAINTAINING ADEQUATE PROTECTION TO ALL IMPROVEMENTS. ANY DAMAGED IMPROVEMENT SHALL BE IMMEDIATELY REPAIRED OR REPLACED AT THE DEVELOPER'S EXPENSE.
 3. MAINTENANCE SHALL INCLUDE BUT IS NOT LIMITED TO STREET SWEEPING, APPLICATION OF A SEALANT ON ALL CRACKS AND JOINTS, AND APPLICATION OF A SEALANT OVER ALL ASPHALT PAVEMENTS.
 4. AT THE TERMINATION OF THE MAINTENANCE AND WARRANTY PERIOD ALL IMPROVEMENTS SHALL BE UNDAMAGED AND SHALL MEET CITY STANDARDS.
 5. IF ALL IMPROVEMENTS ARE NOT ACCEPTABLE AT THE END OF THE ONE YEAR WARRANTY PERIOD, THE MAINTENANCE AND WARRANTY PERIOD SHALL CONTINUE UNTIL THE IMPROVEMENTS MEET CITY APPROVAL.
- D. LANDSCAPED AREAS THAT WILL BE MAINTAINED IN THE FUTURE BY NIBLEY CITY SHALL BE CLEARLY IDENTIFIED ON THE APPROVED PLANS AND ARE SUBJECT TO THE FOLLOWING REQUIREMENTS. THESE AREAS MAY INCLUDE RETENTION BASINS, PARKS, RIGHTS-OF-WAY, AND STREET CENTER MEDIAN LANDSCAPING.
1. THE DEVELOPER SHALL MAINTAIN AND WARRANTY ALL PLANTED AREAS INCLUDING IRRIGATION SYSTEMS FOR A PERIOD OF ONE YEAR BEGINNING IMMEDIATELY AFTER THE CITY ISSUES THE NOTIFICATION OF APPROVAL FOR THE PROJECT.
 2. DURING THE MAINTENANCE AND WARRANTY PERIOD, THE DEVELOPER SHALL BE RESPONSIBLE FOR MAINTAINING ADEQUATE PROTECTION TO ALL AREAS. ANY DAMAGED PLANTING AND OR IRRIGATION SYSTEMS SHALL BE IMMEDIATELY REPAIRED OR REPLACED AT THE DEVELOPER'S EXPENSE.
 3. MAINTENANCE SHALL INCLUDE CONTINUOUS OPERATIONS OF WATERING, WEEDING, REMOVAL OF DEAD PLANT MATERIAL, MOWING, ROLLING, FERTILIZING, SPRAYING, INSECT AND PEST CONTROL, RE-SEEDING, REPLACEMENT, AND ALL OTHER MEASURES NECESSARY TO ENSURE GOOD NORMAL GROWTH.
 4. WHEN THE TURF HAS ESTABLISHED SUFFICIENT ROOT STRUCTURE AND AN APPROXIMATE HEIGHT OF 3-INCHES, MOWING SHALL BEGIN IMMEDIATELY TO A 2-INCH HEIGHT AND SHALL BE MOWED THEREAFTER AND REDUCED IN SAFE INCREMENTS TO A HEIGHT OF 2-INCHES.



-
5. AT THE TERMINATION OF THE MAINTENANCE AND WARRANTY PERIOD ALL TURF AREA SHALL BE LIVE, HEALTHY, UNDAMAGED, AND FREE OF INFESTATIONS. ALL AREAS SHALL BE COMPLETELY VOID OF BARREN SPOTS LARGER THAN 3 INCHES BY 3 INCHES.
 6. IF ALL PLANTINGS ARE NOT ACCEPTABLE AT THE END OF THE ONE-YEAR PERIOD, THE MAINTENANCE AND WARRANTY PERIOD SHALL CONTINUE UNTIL THE LANDSCAPING MEETS CITY APPROVAL.
- E. STRUCTURES WITHIN SIGHT VISIBILITY EASEMENTS WILL BE LIMITED TO A HEIGHT OF THREE (3) FEET; LANDSCAPING WITHIN VISIBILITY EASEMENTS WILL BE LIMITED TO GROUND COVER, FLOWERS AND GRANITE LESS THAN TWO (2) FEET (MATURE) IN HEIGHT AND/OR TREES WITH BRANCHES NOT LESS THAN SEVEN (7) FEET ABOVE THE GROUND. TREES SHALL NOT BE PLACED LESS THAN EIGHT (8) FEET APART.
 - F. THE PROPERTY OWNER SHALL BE RESPONSIBLE FOR THE PROPER MAINTENANCE AND REPAIR OF ALL FACILITIES ASSOCIATED WITH STORMWATER MANAGEMENT ON A PROPERTY.
 - G. THIS DEVELOPMENT IS ADJACENT TO AGRICULTURAL USES AND IS THEREFORE SUBJECT TO NOISE, DUST AND ODORS ASSOCIATED WITH SUCH A USE.
 - H. ALL NEW OR RELOCATED UTILITIES WILL BE PLACED UNDERGROUND (*EXCEPTIONS ARE TO BE NOTED*).
 - I. ALL LOT CORNERS SHALL BE MONUMENTED WITH ½” REBAR WITH CAP, TAG OR OTHER MONUMENTATION AS DESCRIBED BEARING THE REGISTRATION NUMBER OF THE SURVEYOR RESPONSIBLE FOR THEIR PLACEMENT.
 - J. NIBLEY CITY IS NOT RESPONSIBLE FOR AND WILL NOT ACCEPT MAINTENANCE OF ANY PRIVATE UTILITIES, PRIVATE STREETS, PRIVATE FACILITIES OR LANDSCAPED AREAS WITHIN THIS DEVELOPMENT.
 - K. THE PROPERTY OWNER SHALL BE RESPONSIBLE FOR THE PROPER MAINTENANCE OF ALL STORMWATER MANAGEMENT FACILITIES.
 - L. THE STREETS IN TRACT (IDENTIFY TRACT) ARE PRIVATE STREETS, TO BE OWNED AND MAINTAINED BY THE PROPERTY OWNERS ASSOCIATION. AFTER THIS PLAT IS RECORDED, NIBLEY CITY WILL NOT ACCEPT DEDICATION OF THE STREET MAINTENANCE RESPONSIBILITIES UNLESS ALL STREET IMPROVEMENTS AND RIGHTS-OF-WAY MEET CURRENT APPLICABLE CITY STANDARDS. (*DEVELOPMENTS WITH PRIVATE STREETS*)
 - M. MAINTENANCE OF EASEMENTS THAT LIE WITHIN THE BOUNDARIES OF A SUBDIVISION LOT SHALL BE THE RESPONSIBILITY OF THE



HOMEOWNERS OR PROPERTY OWNERS ASSOCIATION, WITH THE FOLLOWING EXCEPTIONS (*RESIDENTIAL AND COMMERCIAL SUBDIVISIONS – LIST THE LOTS AND SPECIFY THE EXCEPTIONS*).

- N. MAINTENANCE OF LANDSCAPING THAT LIES WITHIN THE FRONT YARD OF A SINGLE FAMILY RESIDENCE SHALL BE THE RESPONSIBILITY OF THE HOMEOWNER UNLESS OTHERWISE NOTED ON THIS PLAT. THIS INCLUDES LANDSCAPING WITHIN THE RIGHT-OF-WAY, PRIVATE STREET TRACT, AND/OR PUE. (*RESIDENTIAL SUBDIVISIONS*)
- O. MAINTENANCE OF THE SEWER SERVICE LINE TO THE SEWER MAIN IN THE STREET AND THE WATER SERVICE LINE TO THE WATER METER SHALL BE THE RESPONSIBILITY OF THE PROPERTY OWNER.

Section 1 – General Definitions

1.1 General Definitions.

1. **A Guide to Low Impact Development within Utah:** A reference manual created by Utah Department of Environmental Quality to guide and assist designers of LID practices. The guide can be found online at the DEQ website: <https://deq.utah.gov/water-quality/low-impact-development>
2. **Alley:** A public way used to provide secondary vehicular access to properties that also abut upon a street.
3. **Arterial Route or Street:** A general term including expressways and major arterial streets and interstate, state or county highways having regional continuity.
4. **Benchmark:** A mark affixed to a permanent or semi-permanent object along a line of survey to furnish a datum level. Nibley City base is 4546.58 feet (Nibley City GPS Monument).
5. **Block:** A piece or parcel of land or groups of lots entirely surrounded by public streets, streams, railroads or parks, or a combination hereof, other than alleys; or land which is designated or shown as a block on any recorded subdivision plat or official map or plat adopted by the council.
6. **Certified Percolation Test:** A saturated soil Double Ring Infiltration percolation test completed in accordance with Utah Administrative Rule, R317-4-5 with the exception that the test shall extend 2.0 feet below the bottom of the proposed invert of the pond. These tests shall be done in accordance with the certification requirements by a “qualified individual” as defined in R317-11.
7. **City Engineer:** The individual or firm appointed by the Council to be the City Engineer of the city.
8. **General Plan and Associated Master Plans:** A comprehensive plan, or parts thereof, providing for the future growth and improvement of the city and for the general location and coordination of streets and highways, schools and recreation areas, public building sites and other physical development, which shall have been duly adopted by the City Council.
9. **Planning Commission:** The Nibley City Planning Commission sometimes referred to hereinafter as the Commission.
10. **Collector Street:** A street that provides for traffic movement within neighborhoods of the city and between major streets and local streets and for direct access to abutting property.
11. **Conditional Approval:** An affirmative action by the City Planning Commission or City Council, indicating that approval will be forthcoming upon satisfaction of certain specified stipulations.
12. **Corner Lot:** A lot abutting on two (2) or more intersecting streets where the interior angle or intersection does not exceed one hundred thirty-five degrees (135 degrees). A corner lot shall be considered to be in that block in which the lot fronts.
13. **Council:** The governing body of the City.
14. **Curb or Curb and Gutter:** Sections of concrete that define and help to maintain the edges of asphalt road surfaces. The concrete sections may be flat or of a high

back style. See street cross-section drawings and details located in section 3, standard drawing list.

15. **Development Master Plan (DMP):** A preliminary master plan for the development of a large, unusual or complicated land area, the platting of which is expected in progressive stages. A DMP may be designed by the subdivider, planner and engineer and shall be subject to approval of the Commission.
16. **Detention:** The detaining or holding of water on site and releasing the water from the site into a pipeline, channel, or other water bodies at a slower rate than would otherwise occur.
17. **Detention Basin:** A pond or basin, either above ground or below, that catches the storm water runoff from a contributing area and uses the detention process.
18. **DEQ:** Utah Department of Environmental Quality
19. **DWQ:** Utah Division of Water Quality, a division of the DEQ.
20. **Easement:** A grant by the owner of the use of a parcel of land by the public, a corporation, or persons for specified use and purposes so designated on a plat.
21. **EM 1110-2-1601:** Engineering and Design – Hydraulic Design of Flood Control Channels, CECW-EH-D, US Army Corp of Engineers, June 1994
22. **Engineer:** The duly appointed and acting City Engineer.
23. **Engineering Plans:** Plans, profiles, cross-sections and other required details for the construction of public improvements, prepared by a registered engineer in accordance with the approved preliminary plat and in compliance with existing standards of design and construction by the Council.
24. **EPA:** United States Environmental Protection Agency
25. **Final Approval:** The approval of the final plat by the Council, as evidenced by certification on the plat by the Mayor of the city and all other required city officials as agents.
26. **Final Plat:** A map of all or part of a subdivision providing substantial conformance to an approved preliminary plat, prepared by a registered professional engineer or a registered land surveyor in accordance with the city's subdivision ordinance.
27. **HEC-11:** Design of Rip-Rap Revetment, Hydraulic Engineering Circular No. 11, US Dept. of Transportation, Federal Highway Administration. (FHWA-IP-89-016, March 1989)
28. **HEC-22:** Urban Drainage Design Manual, Hydraulic Engineering Circular No. 22, US Dept. of Transportation, Federal Highway Administration. (FHWA-SA-96-078, August 2001).
29. **HISTORICAL RUNOFF FLOW:** The runoff that has historically flowed off of a given piece of land in the specified storm frequency and duration prior to development, either in the land's pre-development agricultural or native condition.
30. **Improved Lot:** A lot that has all the improvements required by the subdivision ordinances.
31. **Interior Lot:** A lot having but one (1) side abutting on a street.
32. **Irrigation Facilities:** Includes canals, laterals, ditches, conduits, gates, pumps, and allied equipment necessary for the supply, delivery and drainage of irrigation water.
33. **Land Exception:** Any parcel of land that is within the boundaries of the sub-division that is not owned by the subdivider.

34. **Local Street:** A street that provides for direct access to residential, commercial, industrial or other abutting land and for local traffic movements and connects to collector and/or major streets.
35. **Lot:** A piece or parcel of land separated from other pieces or parcels by description, as in a subdivision or on a record survey map, or by metes and bounds, for purposes of sale, lease or separate use.
36. **Lot width:** The width of a lot that shall be:
 - a. If the side property lines are parallel, the shortest distance between these sidelines
 - b. If the side property lines are not parallel, the width of the lot shall be the length of a line at right angles to the axis of the lot a distance equal to the front setback required for the district in which the lot is located. The axis of the lot shall be a line joining the mid-points of the front and rear property lines.
37. **Low Impact Development** – Low Impact Development - refers to engineered systems, either structural or natural, that use or mimic natural processes to promote infiltration, evapotranspiration, and/or reuse of storm water as close to its source as possible to protect water quality and aquatic habitat. LID practices at the regional and site-specific level preserve, restore, and create green space using soils, vegetation, and rainwater harvesting techniques
38. **Major Street:** A street, existing or proposed, which serves or is intended to serve as a major traffic way and which is designated on the master street plan as a controlled-access highway, major street, parkway or by equivalent terms suitable to identify street comprising the basic structure of the street plan.
39. **Marginal Access Street:** A minor street parallel and adjacent to an arterial route that provides access to abutting property and intercepts local streets and controls access to an arterial route.
40. **Minor Street:** A street, existing or proposed, which is supplementary to a collector or major street and of limited continuity, which serves or is intended to serve the local needs of a neighborhood.
41. **Mobile Home Subdivision:** A subdivision designed and intended for residential use where residence is primarily to be in mobile homes.
42. **Neighborhood Plan:** A plan to guide the platting of remaining vacant parcels in a partially built up neighborhood, so as to make reasonable use of all land, correlated street patterns, and achieve the best possible land use relationships.
43. **NOI:** A notice of intent to construct permit obtained from the DWQ which is required for all construction on areas greater than or equal to 1.0 acres.
44. **NOT:** A notice of termination to construction submitted to the DWQ upon the stabilization of 70 percent of the project site that required a NOI.
45. **Official Map:** Any map adopted by the Council under the provisions of Title 17, Chapter 27, Section 7 Utah Code Annotated, 1953 as amended.
46. **One Way Drive Way** – also known as circular driveways, are intended to allow a driver to exit a public right of way and reenter at a different location without having to back out.
47. **Owner:** The person or persons holding title by deed to land, or holding title as vendees under land contract, or holding any other title or record.

48. **Parcel of Land:** Contiguous quantity of land, in the possession of, or owned by, or recorded as the property of, the same claimant or person.
49. **Partial Cul-de-sac:** Cul-de-sac, or bulb out located any other location than at the end of a dead end street.
50. **Pedestrian Path/Trail:** A concrete, asphalt, or gravel path designated for a variety of non-motorized uses.
51. **Pedestrian Way:** A public walk dedicated through a block from street to street and/or providing access to a school, park, recreation area or shopping center.
52. **Planned Unit Development:** A use or combination of uses planned for a tract of land to be developed as a unit.
53. **Park/Planting Strip:** Planting strips are the area between the curb and the sidewalk along conventional streets. See street cross-section drawings and details located in section 3, standard drawing list.
54. **Plat:** A map of a subdivision prepared in accordance with standards of the subdivision ordinance.
55. **Preliminary Plat:** A preliminary map, including supporting data, indicating a proposed subdivision development, prepared in accordance with this ordinance and Utah Code.
56. **PWD:** Public Works Department
57. **Recorded Plat:** A final plat bearing all of the certificates of approval required in this title and duly recorded in the county recorder's office.
58. **Retention:** The retaining or keeping of water on site and preventing its release from the site by any method other than infiltration or evaporation.
59. **Retention Basin:** A pond that is built to capture and retain the design storm on site and dispose of it through infiltration.
60. **Return Frequency:** The frequency or likelihood of a storm of occurring. A 100-year storm has a one (1) percent chance of occurring in any given year while a 10-year storm has a ten (10) percent chance of occurring in any given year. This should never be interpreted as happening only once every 100 or 10 years for the two given examples.
61. **Sidewalk:** A concrete surface along side the planting strip or swales of a street or roadway designated for pedestrian traffic. See street cross-section drawings and details located in section 3, standard drawing list.
62. **Source Protection Zone:** Drinking water source protection zones to delineate area's of land that contribute to groundwater recharge as defined by the maps on file with State of Utah Division of Drinking Water.
63. **Spread Width:** The width of water flow as measured from the flow line of the gutter into the asphalt.
64. **Stream Alteration Permit:** A permit that is obtained through the Utah Division of Water Rights and is necessary anytime construction impacts a stream, wetland, riparian zone, or other water body defined as the waters of the U.S.
65. **Street:** Any street, avenue, road, lane, parkway, place, viaduct, easement for access or other ways which is an existing state, county, or municipal roadway; or a street or way shown in a plat heretofore approved pursuant to law or approved by official action; or a street or way in a plat duly filed and recorded in the county recorder's office. A "street" includes the land between the right-of-way lines, whether

- improved or unimproved and may comprise pavement, shoulder, curbs, gutters, sidewalks, parking areas and lawns.
66. **Storm Event:** The event and hyetograph that define the design volume of precipitation, duration of the storm, intensity of the storm, and the pattern in which the precipitation falls.
 67. **Subdivider:** The individual, firm, corporation, partnership, association, syndication, trust or other legal entity that executes the application and initiates proceedings for the subdivision of land in accordance with the provisions of this title.
 68. **Subdivision:** The division of a tract, lot, or parcel of land owned by a person or legal entity as an undivided tract or parcel into two or more lots or other divisions of land for the purpose of the sale, lease, transfer, use building development, or redevelopment thereof, whether immediate or future. This definition shall not apply to the sale, lease, transfer, use, building development, or re-development of any existing lot that is shown as one of the lots of a subdivision in an approved final plat that has previously been recorded in the offices of the city and county recorders. The word "subdivide" and any derivative thereof shall have reference to the term "subdivision".
 69. **Swale:** The area between the curb and the sidewalk or pedestrian path as used in low impact development (LID). Swales may also be located along private roads and drives. Swales are not always located between the sidewalk and street, but they do almost always run parallel with the street.
 70. **SWPPP:** A storm water pollution prevention plan which is required on any construction site.
 71. **Through lot:** A lot abutting two (2) parallel or approximately parallel streets.
 72. **Underground Injection/Retention System:** A system designed to be fully underground and to dispose of water, entirely or in part, through infiltration. These require a special permit from the DWQ known as a Class 5 injection well permit.
 73. **Underground Injection Well:** A facility, such as a pressured injection well, free draining injection well, sump, or other buried underground facility that infiltrates or injects surface water into the subsurface or groundwater system to eliminate surface runoff.
 74. **Useable Lot Area:** That portion of a lot which is usable for or adaptable to the normal uses of residential property, excluding any areas which may be covered by water, excessively steep, or included in certain types of easements.
 75. **Utilities:** Installations or facilities, underground or overhead, furnishing for the use of the public electricity, culinary water, gas, communications, water drainage, sewage disposal or flood control, owned and operated by any person, firm, corporation, municipal department or board duly authorized by state or municipal regulations. Utility or utilities as used herein may also refer to such persons, firms, corporations, departments, or boards as applicable herein.
 76. **Wetlands Mitigation, or 404, Permit:** A permit obtained through the US Army Corp of Engineers which allows the wetlands to be impacted and provides for required mitigation before the project can be approved.
 77. **Zone 1:** Zone 1 as delineated and shown on Source Water Protection Zone map approved by the Utah Division of Drinking Water.

78. **Zone 2.** Zone 2 as delineated and shown on Source Water Protection Zone map approved by the Utah Division of Drinking Water.

Section 2 - Development Standards

2.1 Engineering Reasonability

- A. The City's Design Standards do not relieve the developer's engineer from being responsible for examining and understanding local project conditions, confirming the correlation of all design standards with the techniques of construction, coordination of the standards with that of all other industry standards, and for the complete and satisfactory design of the project.

2.2 Issue's not covered by these standards

- A. All work not specifically described in these design standards and technical specifications shall conform to the APWA Manual of Standard Specifications as published by the Utah Chapter of the American Public Works Association. The latest edition referenced by these standards shall be used.

2.3 Impact on Existing Infrastructure

- A. The impact on existing infrastructure, will be reviewed by the City. The developer may be required to add additional off-site improvements in order to provide adequate service to the development.

2.4 Compliance with City Subdivision Ordinance

- A. Included herein by reference is the current Nibley City Zoning and Subdivision Ordinances as approved by the City Council. If a discrepancy exists between these design standards and the subdivision ordinance, the ordinance shall govern.

2.5 Compliance with City General Plan and Master Plans

- A. All Subdivisions shall comply with the City's most recent General Plan and associated Master Plans.

2.6 Required Studies, reports and plans: The following studies, reports, and plans shall be required on all developments, if in the opinion of the City Engineer, Public Works Director and/or City Council; they are determined to be necessary for the development of the project:

- A. Geotechnical Report. A geotechnical report shall be prepared by a qualified engineer, and must contain at least the following information:
 1. A slope Analysis with a contour map
 2. Classification of slopes on the site
 - a. Class 1: Areas of Non-Steep slopes - less than 30%
 - b. Class 2: Areas of steep slopes - 30% or greater

****Note:** Percentages shall be calculated as prescribed by the definition for "Steep Slopes". If the subdivision contains any areas of steep slopes, the person or firm preparing the soils report shall identify the class 2 areas, and should designate those areas as "Non-Buildable Areas" on the subdivision plat. If in the opinion of the qualified engineer any class 2 areas should not be designated as non-buildable areas, the report should include reasons why an exception should be made. The City Engineer will have final determination of such areas. ******

3. Soils Engineering properties including, but not limited to:
 - a. Bearing capacity
 - b. Settlement potential
 - c. Slope failure potential
 - d. Shrink/swell potential of the site.

****Note:** Testing should be completed adequately to determine if the existing soil on the site is suitable for public infrastructure. If there any indications that the soil is not suitable for the type of development, the report shall include mitigation strategies for public infrastructure. In such a case, the Final Plat shall also put owners on notice that building on these soils will require on-site investigation and lot-specific soils hazard mitigation plans. ******

4. An estimate of the normal highest elevation of the seasonal high-water table based on piezometer-tube testing and the locations of swamps, seeps or springs with the reasons for the occurrence of these underground water sources.
5. Percolation test performed by a certified testing agency.
6. A written statement of the person or firm preparing the geotechnical report identifying any other means proposed to minimize hazards to life, property, and adverse effects on the safety, use or stability of public rights of way or drainage channels, and adverse impacts on the natural environment.
- B. Geologic Hazard Report. A geologic hazard report shall be prepared by a person or firm qualified by training and experience to have expert knowledge of geologic hazards and must identify the author and date of the data upon which the report is based. The report must include an analysis of the geologic conditions, conclusions regarding the effect of the geologic conditions on the development and recommendations covering the adequacy of sites to be developed within a recognized geologic hazard. It shall also include a written statement identifying the means proposed to minimize hazards to life or property, adverse effects on the safety, use, or impacts on the natural environment.
- C. Water Conservation Plan. A water conservation plan shall contain an assessment of the potential outside culinary water use for the subdivision and recommendations for lot size, landscaping, and irrigation practices to minimize culinary water use. For land with irrigation water rights the conservation plan should contain an assessment and recommendations for development of a secondary water system.
- D. Traffic Report. A Traffic report shall describe the traffic impacts that will be created by the project including but not limited to peak period trip generations rates, impacts on turning movements and road segment level of service and proposals to mitigate the impacts.

E. Fire Protection Plan. Fire Protection plan shall be required by any subdivision that in the opinion of the City Fire Authority may be susceptible to wild fire. The plan shall include as a minimum the plans for any needed firebreaks and planned fire-wise construction and/or landscaping for the subdivision.

2.7 Non Buildable Area's. Non-buildable areas shall be designated on the preliminary and final plat by shading and shall have a designation of "Non-Buildable" shown on the plat. Final determination will be made by Public Works Director.

A. The areas with the following characteristics will be considered for designation as Non-Buildable:

1. Areas of Steep Slopes as defined in Nibley City Design Standards Definitions
2. Areas with soils found to be unsuitable for development by a Geotechnical Report
3. Natural drainage corridors, canal channels and wetlands
4. Any areas identified by any required studies as potentially hazardous to life, limb or property
5. Fire Breaks

B. No homes, buildings, or other structures, streets or alleys shall be erected or built on areas designated and platted as "Non-Buildable".

2.8 Utilities. To the maximum extent practical, all utilities shall be placed within existing road rights of way and front yard public utility easements. All water, sewer, electrical, telephone, natural gas, cable television, communications and other utilities shall be placed underground except for transformers, pedestals, and other appurtenances which are normally located above ground.

2.9 Easements. In the event that all utilities are not able to be placed within existing road rights of way or easements, a min 20 foot wide utility easement shall be required (10 feet on each side of the utility), and recorded at the Cache County Records Office.

Section 3 – Drawing Requirements – Plat & Construction

3.1 Final Plat Signature Boxes.

- A. Surveyor's Certificate: the form of the professional surveyor's certificate shall be substantially as follows:

SURVEYOR'S CERTIFICATE

I, _____, a Registered Land Surveyor, hold Certificate No. _____, as prescribed by the laws of the State of Utah, and do hereby certify that by authority of the owners, I have made a survey of the tract of land shown on this plat, which is accurately described therewith, and have subdivided said tract of land into lots and streets to be hereafter known as _____, and that the same has been surveyed and staked on the ground as shown on this plat.

Signed on this ____ day of _____, 20__

- B. Owners Dedication: A specific statement of dedication of all streets, alley, crosswalks, drainage ways, pedestrian ways and other easements for public use by the person holding title of record, by persons holding title of record, by persons holding title as vendees under land contract, and by wives of said parties shall be required. If land dedicated are mortgaged, the mortgaged shall also sign the plat, and if subject to a Real Estate Contract, the seller or actual owner of the real property being subdivided shall also sign the Final Plat. Dedication shall include a written location by section, township and range, of the tract. If the plat contains private streets, public utilities shall be reserved the right to install and maintain utilities in the street right-of-way. The form of the owner's dedication shall be substantially as follows:

OWNER'S DEDICATION

Know all by these presents that we the undersigned owners of the above described tract of land, having caused the same to be subdivided into lots and streets to hereafter be known as _____, do hereby dedicate for perpetual use of the public all parcels of land shown on this plat as intended for public use, and do warrant, defend and save the municipality harmless against any easements or other encumbrances on the dedicated streets which will interfere with the municipality's use, operation and maintenance of the streets and do further dedicate the easements as shown, with the same warranty as given for other dedicated property.

In witness whereof, we have hereunto set our hands this _____ day of _____, 20_____.

Signed

Signed

C. Required Acknowledgements

1. Acknowledgement

STATE OF UTAH)

ss. _____

COUNTY OF CACHE)

On the _____ Day of _____ A.D., 20_____, personally appeared before me, the signer(s) of the above Owner's Dedication, who duly acknowledged to me that he/she/they signed it freely and voluntarily and for the uses and purposes therein mentioned.

Notary Public

2. Corporate Acknowledgement

a. STATE OF UTAH)

ss. _____

COUNTY OF CACHE)

On the _____ Day of _____ A.D., 20_____, personally appeared before me, _____ and _____, who acknowledged to me that they are the _____ and _____ of corporation, that they signed the Owner's Dedication freely and voluntarily and for and in the behalf of the corporation for the purposes therein mentioned and that the corporation executed the same.

Notary Public

- b. The form of a corporate, partnership, or other entity signature shall include a provision or a Notary in which the subdivider represents that the person signing for the corporation, partnership, or other entity has the authority to execute the agreement for the corporation, partnership, or other entity.

- E. Engineer's Certificate: the form of the Engineers Certificate shall be substantially as follows:

Engineers Certificate

I certify that I have examined this plat and find it to be correct and in accordance with the information on file in this Office and the city ordinance.

City Engineer

Date

- F. Utility Company Approvals: All utility companies must acknowledge and accept the easements as shown on the final plat. At a minimum the following company's signatures must be obtained:

Utility Company Approvals

Questar Gas

Date

Rocky Mountain Power

Date

Century Link

Date

Comcast Communications

Date

- G. Planning Commission Approval and Acceptance: the form of the Planning Commission Approval and Acceptance shall be substantially as follows:

Planning Commission Approval and Acceptance

Presented to the Nibley City Planning Commission this ____ day of _____, 20____, at which time this subdivision was recommended to the City Council for approval.

Planning Commission Chairman

Date

- H. City Council Approval and Acceptance when required by ordinance: the form of the City Council Approval and Acceptance shall be substantially as follows:

City Council Approval and Acceptance

Presented to the Nibley City Council this ____ day of _____, 20____, at which time this subdivision was approved and accepted.

Mayor

Date

- I. Attorney Approval: the form of the City Attorney Approval and Acceptance shall be substantially as follows:

Attorney Approval

Approved as to form this ____ day of _____, 20____.

City Attorney

Date

- J. County Recorders No: the form of the Cache County Recorder's No shall be substantially as follows:

County Recorders No.

State of Utah, County of _____, recorded and filed at the request of:

Date: _____ Time: _____ Fee: _____

Abstracted _____

Index _____

Filed in: File of plats

County Recorder

- K. Ground Water Note: This note shall be required on all plats.

Groundwater Note:

Areas in Nibley City have groundwater problems due to the varying depths of a fluctuating water table. The city's approval of a building permit or construction plans does not constitute a representation by the city that building at any specified elevation or location would solve subsurface or groundwater problems. In addition, concerns for building elevation and/or grading and drainage are unique to each building lot and site. Responsibility for these stated concerns, and all other such concerns related to a lot or other building site, remains solely with the building permit applicant, property owner and/or contractor. Nibley City is not responsible for any subsurface or groundwater problems which may occur, nor for other such concerns, including, but not limited to, building location and/or elevation, site grading, and drainage.

M. Other Notes required per Ordinances

3.2 Construction Plan Requirements

- A. Plan views of the street improvement shall be to a scale not greater than 1"=50' on new subdivisions and street improvements and shall contain the following information:
1. Any existing street curbs, driveways, and property lines, right-of-way, and utility easements referenced to property corners, street intersections, or section lines within 300-feet of proposed construction. Running grade, existing cross slopes, and curb elevations shall be required to determine if finished design grades will provide a smooth transition from existing to new construction.
 2. Catch points and limits of slope for all cuts and fills.
 3. Location and sizes of water courses, stream and railroad crossings, water mains, culverts, sanitary sewers, and storm sewers, including any of the mentioned pipe inverts within 300-feet of the proposed project. Use arrows on both existing watercourses and storm drains, and on proposed storm drains, indicating direction of flow.
 4. Location of wells (public or private), gas mains, underground power, and any other utility (public or franchised) within 100-feet of the proposed project.
 5. On horizontal curves, show stationing of the point of tangency and the point of curvature. Show the length of tangent, length of centerline curve, the delta angle, radius point, and centerline radius distance.
 6. On half or three-quarter street improvements show the existing centerline, edges of pavements, and the extent of the proposed widening, i.e. the location of the opposite curb and right-of-way. Show running and cross slopes of all proposed and existing surfaces, sufficient to show proper slopes of tie ins and transitions.
 7. Show all ADA ramps on each curb radii.
 8. The location of each manhole, catch basin, beginning and end of radius, point of curvature, and point of tangent shall be stationed to facilitate checking the plans with the profiles. The stationing shall be tied to existing property corners, centerline, centerline of intersections, and/or street monuments.
 9. Side streets shall be stationed at the centerline of the intersection.
- B. Profile Views. Profiles for the individual street shall be to the same horizontal scale on the same sheet and drawn immediately below the corresponding plan view to a vertical scale of 1"=5' reading from 0+00 left to right (where conditions warrant, right to left

may be approved as well as a different vertical scale), and shall contain, in addition to the above, at least the following information:

1. Location of catch basins, manholes, and other appurtenances with each numbered and stationed.
2. Profile of existing and finished ground line at property line and/or pavement, left and right curb line, and proposed centerline.
3. Percent of all street grades.
4. Beginning of all vertical curves, points of vertical intersection, ends of vertical curve, low point of vertical curve (if a sag curve) and length of vertical curve.
5. Design speed used and "K" value applied.
6. On half street or three-quarter improvements show elevations of the centerline, edge of pavement, and proposed top of curb for 300-feet in each direction of the improvement. Show running and cross slopes of all proposed and existing surfaces, sufficient to show proper slopes of tie ins and transitions.
7. Profiles on stub streets shall be shown 300-feet past the terminus of the street.
8. Street Transitions Street tapers to match new or widened streets to existing adjacent street improvements shall normally be in accordance with AASHTO standards, but shall be a minimum of 10:1 for Local Streets and 20:1 for Collector and Arterial Streets.

SPECIAL NOTE: The design engineer shall field locate and verify the alignment, depth, and inverts of all existing facilities shown on the plans that will be crossed by proposed facilities and shall certify them with a note on the plans. City as-builts are only to be used as an aid to the design engineer when field verifying the existing facilities



CHAPTER 4

WATER SYSTEMS

4.1	Potable Water System Standards	3
4.1.1	General Information	3
A.	Introduction	3
B.	Abbreviations	3
C.	Development Requirements	4
D.	City Policies	5
4.1.2	Water Plans	6
A.	Modeling Requirements	6
B.	Construction Plan Requirements	8
C.	As-Built Drawings	10
4.1.3	Production Systems – See Separate Document.....	10
4.1.4	Water Lines	10
A.	General Information	10
B.	Transmission Lines	11
C.	Distribution Lines	12
D.	Service Connections	12
E.	Water Quality Division	20
F.	Pipe Materials	20
G.	Locating Water Lines.....	21
H.	Cover and Bedding Requirements	23
I.	Pressure Requirements.....	24
J.	Miscellaneous Requirements and Specifications.....	25
4.1.5	Valves and Zone Splits.....	26
A.	General Valve Requirements	27
B.	Underground Chambers	29
C.	Air Release Valves	29
D.	Pressure Reducing Valves	30
E.	Zone Splits.....	31
4.1.6	Fire Lines and Associated Equipment	31



A.	Fire Lines	31
B.	Fire Hydrants.....	32
C.	Fire Department Connections.....	35
D.	Fire Flow Requirements	36
E.	Fire Equipment & Storage Facilities	36
4.1.7	Cross-Connection Control	36
A.	Implementation	37
B.	Installation	38
C.	Maintenance	39
4.1.8	Secondary Water Systems	39
A.	Materials	39
B.	Systems of City Water and Secondary Water	39
C.	Ownership.....	40
4.2	Water Main Flushing and Disinfection Guidelines.....	40
4.2.1	Regulatory Standards.....	40
4.2.2	Valve Operation	40
4.2.3	Isolation of New Water Mains	41
4.2.4	Protection of Pipe, Valves, and Fittings	41
4.2.5	Loading the Main for Pressure and Leak Testing.....	41
4.2.6	Flushing	42
4.2.7	Disinfection of Mains	42
4.2.8	Bacteriological Testing and Acceptance	43
4.2.9	Connection of New Main	43



4.1 Potable Water System Standards

4.1.1 General Information

A. Introduction

This document provides guidance and minimum design criteria for the modification and construction of water systems within Nibley City. It is intended for use in the planning, design, plan preparation, and construction processes. These standards are intended to follow State of Utah (hereafter “Utah”) regulations in assuring that City facilities are: reliably capable of supplying potable water in adequate quantities, consistently meeting applicable state drinking water quality requirements, and do not compromise general public health. In the event a part of these standards is found to conflict with Utah standards, Utah standards shall prevail.

The City maintains a citywide Water Master Plan that has been developed to ensure that the City’s water system develops in an organized manner. Contact the City Engineer for further information regarding latest editions and updates to this Master Plan.

Wherever the language of this document refers to equipment or material to be used, or the language of a standard refers to an Approved Materials List, the “Potable Water System Approved Materials List” shall be used. The “Water Line Flushing Procedures” documents shall be followed when installing new meters and water lines. These documents can be obtained from the City’s City Engineer or from the City’s website, www.nibleycity.com.

B. Abbreviations

1. ACP - Asbestos Cement Pipe
2. APWA - American Public Works Association
3. AWWA - American Water Works Association
4. ARV - Air Relief Valve
5. DDW - Division of Drinking Water
6. DIP - Ductile Iron Pipe
7. FDC - Fire Department Connection
8. HDPE - High Density Polyethylene
9. IPC - International Plumbing Code
10. IRC - International Residential Code
11. NFPA - National Fire Protection Association



- 12. PRV - Pressure Relief Valve
- 13. RPP - Reduced Pressure Principle
- 14. PVC - Polyvinyl Chloride
- 15. SCADA - Supervisory Control and Data Acquisition
- 16. USC - University of Southern California
- 17. VFD - Variable Frequency Drive

C. Development Requirements

1. Water Mains of a size required for the development or of a size required by the City shall be extended in all new roadways within a development and within all adjacent roadways to a development unless otherwise approved by the City Engineer. Unless otherwise agreed to in a development agreement, where the City requires larger pipe than what is needed for the development or in a location that isn't necessary to serve the development, the City will participate in the construction of that infrastructure.
2. The Developer shall install, at his/her own expense, all on-site and off-site improvements necessary to service a proposed development. This may include but is not limited to: pump stations, reservoirs, transmission mains, fire lines, fire hydrants, pressure reducing valves, and all other facilities necessary to service the development. The Developer shall also remit payment to the City of all City required development related fees. Dependent upon available City Budget, On-site and Off-site improvements that are oversized for the needs of the development may be candidates for partial reimbursement from the City.
3. Each development shall be supplied with safe, reliable, and potable water in a sufficient volume and pressure for domestic use and fire protection. At a cost to the developer, the City's designated engineer shall model the proposed water system to verify that minimum flows and pressures will be met during peak day plus fire flow, peak instantaneous, and average day scenarios. The flows and pressures must meet minimum requirements for domestic use and fire flow. Individual home booster pumps are not allowed.
4. For planning purposes, the pressures and flow capacities in an area can be obtained from the Water Master Plan. For construction plan approval, current system pressures and



flow capacities shall be obtained by performing a fire hydrant flow test of that part of the potable system to be extended.

- a. At a cost to the developer, the City's designated engineer shall model the proposed system in the City-wide water model. The developer shall complete all other regulatory requirements for system approval. In accordance with Nibley City Code (21.06.040.A.4), the water model and preliminary water report are required at submission of the Preliminary Plat. Contact the City Engineer to schedule this work.
5. If a building is to be supplied with fire flows from a storage tank or facility that is not City owned, the Design Engineer must provide a report indicating that sufficient volumes exist as required by the Fire Authority.
6. Upon development of property within the City limits, the Developer shall submit construction plans for the water system. The plans shall be prepared by a Professional Engineer licensed in the State of Utah. All water lines and facilities constructed within the City limits shall be inspected and accepted by Nibley City prior to being placed into service.
7. The City requires developers to install water mains along street frontages of developments, where future extension of a water line is required by the City Engineer. The street frontage is that portion of the property adjacent to a public right-of-way and/or public utility easement. If a parcel to be developed has more than one street frontage, water mains shall be installed along each frontage.
8. For current information on ordinance requirements, review of the Nibley City Code of Ordinances is recommended.

D. City Policies

Proposed developments that alter land use and are determined by the City Engineer to have a significant impact on the City Master Water Plan, and/or propose a water system that differs from the City's Water Master Plan, shall be financially responsible to have the City's Water Master Plan and City-wide water model updated to reflect changes. The effects of Peak day Demand + Fire Flows, and



all other water demand scenarios from these developments, will be reviewed by the City Engineer to verify the sizing and layout of the proposed water system elements. This information will also be used to assist the City in planning for current and future developments.

4.1.2 Water Plans

A. Modeling Requirements

1. Preliminary Water Information

a. Preliminary information regarding the water system for a development shall be provided for all General Plan Amendments, Zoning, Site Plan, and Preliminary Plat applications. The preliminary information provided within these documents shall at a minimum show the conceptual location and size of the existing and proposed water distribution and transmission mains, fire hydrants, and valves within and adjacent to the site. If applicable the water zone breaks, storage and booster facilities, and other unique water system related items shall also be shown.

i For site plan and preliminary plat developments that will be constructed in phases, a water model and related reports sufficient to confirm the water system and line sizes are adequate for the improvements is also required.

2. Water Modeling / Reporting Requirements

A water model shall be developed for each project in which the project is to be designed and constructed, including projects proposed to be constructed in a phased succession. Phased projects shall be clearly identified in design documents.

The water model and reports for phased developments will provide a governing plan by which each phase shall adhere. Based on results of the water model, reports shall be prepared in accordance with this manual or as otherwise directed by the City Engineer and shall be signed and sealed by a Professional Engineer registered in and licensed to practice in the State of Utah.



The objective of the model and report is to provide sufficient information to adequately review the water design for a proposed project, including projects proposed to be constructed in phased succession.

- a. At a cost to the developer, the City’s designated engineer shall model the proposed system in the City-wide water model. The developer shall complete all other regulatory requirements for system approval. In accordance with Nibley City Code (21.06.040.A.4), the water model and preliminary water report are required at submission of the Preliminary Plat. Contact the City Engineer to schedule this work.

At a minimum, the water model and report shall confirm the following:

- a. The adequacy of available storage.
- b. Capacity to meet fire plus peak day demand scenarios.
- c. Acceptable pressure during fire flow plus peak day demand scenarios.
- d. Modeling
 - i. A water model demonstrating that system pressures do not exceed the maximum nor fall below the minimum pressures, as identified in this chapter, will be required. Reporting of the model results shall be provided to confirm.
 - ii. The water model shall specifically verify that minimum pressures are available within the development’s system during the Peak day Demand +Fire Flow demand scenario.
 - iii. At a cost to the developer, the City’s designated engineer shall model the proposed system in the City-wide water model.
 - iv. The following scenarios shall be modeled:



- (1). Average Day Demand scenario - based on 0.75 gpm/ERU. See the Water Master Plan for ERU equivalents.
- (2). Peak Day Demand scenario – 2.49 times the Average Day Demand.
- (3). Peak Day Demand + Fire Flow.
- (4). Peak Instantaneous Demand – 3.63 times the Average Day Demand.
- (5). Fire flows shall be determined per the Fire portion of this chapter.
- (6). See the Pressure Requirements section of this chapter for minimum and maximum pressure design requirements.
- (7). Pipeline calculations verifying that head loss per 1,000 feet of any pipe is no greater than 10 feet/feet during peak period demand conditions, and not more than 8 feet/feet under any peak day condition.
- (8). Sufficient supply for domestic demand must be provided without the use of dedicated fire pumps or backup pumps.

B. Construction Plan Requirements

1. Review Guidelines

The following paragraphs highlight construction plan requirements pertaining to the preparation of water improvement plans which are to be submitted to the City for approval:

- a. General Construction Notes and Water Construction Notes which apply to construction of Nibley City's water system are required on each set of construction plans which include work on the City's water system or a water system which is to be dedicated to the City.



These notes are provided in the Administrative chapter of this manual.

2. Water line stationing shall be along the pipe, monument, or roadway centerline.
3. If a line is to be connected to an existing system, the following note shall be placed on the plans: “Contractor shall verify the location of the existing water line prior to proceeding with trenching”.
4. The end invert elevation shall be shown on all proposed water main stubs (profile required for lines 8 inches and larger).
5. Where water lines cross sewer lines, storm drains, secondary water lines, or drainage culverts, the relationship shall be shown in both plan and profile and actual separations shall be called out.
6. For permitting purposes, quantities for all items of work within public rights-of-way and public easements shall be included on the cover sheet of the plans, unless otherwise approved in writing by the City Engineer.
8. The drawings shall show all utility locations, sizes, material types, easements, rights-of-way, and other structural features for current and future building construction.
9. Private water lines shall be noted as such on plans. The responsibility for operation and maintenance shall also be noted on the plans.
10. Easements of record shall be shown in plan view and noted with the easement type, width, and associated docket and page numbers and/or the Cache County Recorder’s number.
11. Prior to issuance of a water construction permit, a construction schedule shall be included in table format for all water-related construction required to serve a development, when required by the Public Works Director or City Engineer.



C. As-Built Drawings

A City-approved set of As-Built Drawings are required for all water system improvements constructed in the City prior to acceptance of the system and start of the 1-year warranty period. As-built plans shall be signed and sealed by a qualified Professional Registrant in the State of Utah, where deemed appropriate by the City Engineer.

4.1.3 Production Systems – See Separate Document

4.1.4 Water Lines

A. General Information

The City potable water delivery system has three basic classifications of water lines which are determined by use. These classifications are transmission, distribution, and service.

1. All developments shall design and construct water transmission, distribution, services, and associated equipment of appropriate size, material identified through the City's Master Plan and the project modeling.
2. All system materials that may come in contact with City drinking water shall be stamped with the NSF logo certifying that the material meets the requirements of ANSI/NSF Standard 61.
3. All system materials shall be "lead free" in accordance with section 1417 of the Federal Safe Drinking Water Act.
4. All system materials (including meters and setters) shall be protected from freezing. Sufficient cover and at times insulation may be required to provide adequate protection.
5. Previously used materials are not allowed to be placed back in service in the City's water system. However, upon prior approval from the City, fire hydrants in which all parts have been completely refurbished.
6. The City Construction Inspector shall be contacted 48 hours prior to all water system shutdowns. The Contractor shall have



all materials and equipment necessary to do the work at the job site prior to shut down.

- a. Only City personnel shall operate City water valves. Contactors that are found to be operating City valves will be shut down until the City can provide adequate training to the Contractor.
 - b. It shall be the Contractor's responsibility to provide all affected water customers with a written notice of the proposed shutdown. Such notice shall be given a minimum of 24 hours in advance.
7. Water mains shall be identified by:
- a. 12 gauge, solid copper tracer wire shall be run with pipe. Locating tape labeled WATER shall be placed a minimum of 36" above the water main or just below the pavement section (pit run for road) if less than 36" above the pipe.

B. Transmission Lines

Transmission lines are used to convey potable or raw water to storage tanks or other points of distribution. In general, they have line sizes of 16 inches and larger, are located in arterial or collector streets, and have no service connections.

1. Developments shall have water lines installed per the City's Water Master Plan.
2. When existing or future development requirements are such that a transmission water line is required, then a transmission water line of a size approved by the City Engineer and designed and sealed by a Professional Engineer shall be constructed by the Developer.
3. Design flows for transmission mains shall be based on the current City General Plan and City Water Master Plan. The flow to a new development shall be calculated to confirm that existing supply is sufficient to meet the proposed development's need. When additional improvements are required to increase the flow to a development, all necessary improvements, including but not limited to, pumping stations,



reservoirs, lines, and appurtenances shall be a part of the design.

4. Peak flow calculations on transmission mains shall be based on fire flow figures in accordance with the City's standards.
5. Service connections shall not be made to mains 16 inches or larger in diameter or to water lines designed solely to transmit water from one pressure zone to another pressure zone.

C. Distribution Lines

Distribution lines typically have sizing of 8 inches to 12 inches in diameter, and are located in arterial, collector or local streets. Distribution mains are supplied by transmission lines and may have service connections.

1. See the City's Approved Materials List for approved materials.
2. Arterial street alignments shall have 12-inch minimum diameter lines.
3. Eight-inch diameter pipe shall be the minimum diameter of a distribution main installed in any street or public easement.
4. These are minimum guidelines; the City may require larger sizes, different materials, and varying locations depending on circumstances.
5. Service connections shall not be made to mains 16 inches or larger in diameter or to water lines designed solely to transmit water from one pressure zone to another pressure zone.

D. Service Connections

A service connection includes the water line from the distribution main to the meter and includes the meter and all connections.

1. Water Services
 - a. Water meter size shall be based on flows as determined by the design engineer. In circumstances where no engineer of record exists, 1-inch water service lines shall be provided in new residential



connections to properties less than 1 acre. 2-inch water service line shall be constructed to properties 1 acre or larger.

- b. Water service lines shall be the same size as the water meter from the connection at the water main to the meter.
- c. The Developer is responsible for application and payment of all applicable fees.
- d. Water service lines maintained by the City shall be installed within a public right-of-way, PUE, or 20-foot minimum width dedicated water line easement.
- e. Meters maintained by the City shall be installed between the curb and sidewalk in the center of parkstrip. If the development is constructed with LID stormwater swales, meters shall be installed within public right of way/PUE near back of sidewalk. Where there is no sidewalk, meters shall be installed within a public right-of-way, PUE, or 20-foot minimum width dedicated water line easement.
- f. All water service lines shall be constructed perpendicular to the centerline of the road and shall extend to the outside edge of the PUE.
- g. Within the right-of-way, cover for water service lines shall be a minimum of 60 inches measured from existing or proposed finished grade of pavement or natural ground, whichever measurement is greater and results in adequate pipe cover.
- h. Construction plans shall indicate the locations of service lines and sewer taps to each unit referenced, with stations and dimensions from the street center line or monument line. Location of the sewer service relative to the water service shall also be shown. Water and sewer services shall be separated 10-feet horizontally from each other and located 5-feet from property lines on opposite corners of a lot.
- i. Service connections shall not be made to mains 16 inches or larger in diameter or to water lines designed solely to



transmit water from one pressure zone to another pressure zone.

- j. All service lines for potable water use shall be a separate dedicated line that is tapped off the water main within a public right-of-way, PUE, or water line easement. In commercial, industrial, and multi-family developments, the potable domestic water service shall be separate from the potable irrigation water service line. Service lines shall connect to an approved private water main or to City mains and shall not be connected to private fire lines.
- k. Branched/manifolded water service line tees are allowed under the following conditions:
- When serving a single residential structure of 4 residential units or less;
 - The water service line is 2-inches in diameter;
 - The branch connection is serviced by a 4-inch gate valve at the water main line;
 - The branch/manifold occurs in the parkstrip with public street frontage prior to branching to individual 1-inch water meters. If the project is provided with LID Swales, meters and manifold shall be located within 1-foot behind sidewalk;
 - Individual 1-inch meters are provided to each unit and are located within individual meter barrels clustered in the same area and installed in accordance with this standard; and
 - The City will own and maintain only the water meters, The water service including the valve, service line, branch, manifold, individual water meter barrels and setters are under private ownership and are maintained by the entity being serviced (HOA, developer, etc.).
 -
- l. New water service lines shall be continuous from the main to the meter and **shall not** use coupling devices to extend service lines that are too short.
- m. Tracer wire and locating tape is required on all services and shall be installed with the service line. Tracer wire



shall be accessible and installed with sufficient length to extend to the top of the meter barrel or vault.

- n. Services damaged after installation are required to be replaced back to the corporation stop.

2. Water Meters

a. General Information

Water meters 2-inch and smaller are purchased and installed by Nibley City. Review the approved materials list for information regarding City water meters. Water meters greater than 2-inch shall be purchased by the City and installed by the Developer after approval from the City Engineer. Meter types and configurations are determined specific depending on the type of project. Contact the City Engineer to discuss your project and the meter type allowed.

- b. Each detached single-family residence shall have a separate water meter installed. (Exception for permitted Accessory Dwelling Units (ADU)).
- c. Each individual commercial building that uses water shall have a separate water meter installed. Commercial buildings that have separate tenants may have individual water meters installed or may be served by a single larger meter on condition that the City bills a single property association.
- d. Commercial developments shall install separate potable use and potable irrigation water meters.
- e. Multi-family developments
 - i. Each unit of a multi-family structure containing 4 units or less shall be served by an individual 1-inch meter. (Branched/manifolded meters in this case are allowed as described below).
 - When serving a single residential structure of 4 residential units or less;
 - The water service line is 2-inches in diameter;
 - The branch connection is serviced by a 4-inch gate valve at the water main line;

- The branch/manifold occurs in the parkstrip with public street frontage prior to branching to individual 1-inch water meters. If the project is provided with LID Swales, meters and manifold shall be located within 1-foot behind sidewalk;
 - Individual 1-inch meters are provided to each unit and are located within individual meter barrels clustered in the same area and installed in accordance with this standard; and
 - The City will own and maintain only the water meters, The water service including the valve, service line, branch, manifold, individual water meter barrels and setters are under private ownership and are maintained by the entity being serviced (HOA, developer, etc.).
- ii. Each multi-family structure containing more than 4 units shall install a water meter no smaller than 2-inch. The engineer of record shall determine through calculations, the appropriate meter size to handle flows.
- iii. The City will bill the HOA for the meter usage, sewer usage, and solid waste; the HOA shall be responsible for collecting proportional shares of the bill from each unit.
- iv. The owner or HOA shall be responsible for maintenance of the service lines past the City meter, except private water systems and branched/manifolded water services serving 4 or less residential units in a single structure where HOA responsibility begins at the valve connecting to the City water main.
- f. There shall only be one water meter per service line (Except branched/manifolded services serving 4 or less residential units in a single structure).
- g. Manifolding, combining, or connecting several smaller meters to meet a flow demand that could be provided by a single larger meter is not permitted.



h. Water meters shall be sized and designed in accordance with these standards and requirements of the IPC/IRC as adopted by the City. Any field changes shall require a letter from the developer with an approval from a registered engineer and the City Engineer.

i. Water Meter Installation

All water meters shall be provided by the City, after payment of all prevailing fees. 1-inch and 2-inch meters are available. 4-inch and 6-inch meters are acceptable for larger service needs.

- i. All 1-inch to 2-inch water meters shall be installed by City Public Works personnel.
- ii. Water meters 4 inches and 6 inches shall be purchased by the City and installed by the Developer in accordance with City Standards and APWA Standard Specifications as amended by the City. After installation, City personnel will inspect and accept the work if all requirements for installation are met.

j. Water Meter Locating

- i. Meters maintained by the City shall be installed along street frontages between the curb and sidewalk in the center of parkstrip. If the development is constructed with LID stormwater swales, meters shall be installed near back of sidewalk. Where there is no sidewalk, meters shall be installed within a public right-of-way, PUE, or 20-foot minimum width dedicated water line easement.
- ii. Water meters shall not be located in driveways, sidewalks, manmade or natural drainage channels, swales, or retention/detention basins.
- iii. Water meters shall not be fenced in or enclosed and must be accessible by City personnel at all times.



-
- iv. If an existing water service/meter must be relocated, a contractor or property owner may relocate the service a maximum distance of 10 feet, provided the joint is not below concrete, asphaltic pavement or other permanent surfaces without prior approval from the City Engineer. If the desired relocation is greater than 10 feet, the old service must be severed and shut off and capped with an approved leak clamp at the main; a new service shall be installed by a licensed contractor. Both services shall be noted on the “as-built” drawings.
3. Water Meter Barrels (cans) and Vaults
- a. General Requirements
 - i. Finished grade of the meter lid shall be within one inch of nearest concrete surface. If no concrete exists, finished grade shall be within one inch of surrounding existing surface
 - ii. Water meter lids shall be constructed with a 2-inch recessed hole for installation of a meter antenna.
 - b. Single-Family Residential and 1-inch Water Meter Cans
 - i. A minimum 18 1/2 clear space shall be provided for access through the meter can lid.
 - ii. The inside diameter of the can shall be 21 inches and shall be of a white HDPE pipe or black corrugated HDPE pipe. It is recommended that 4-foot lengths of HDPE be installed in order to account for new meter depth requirements noted below.
 - iii. The shut off valve of each 1-inch setter shall measure 24-inches to 30-inches below the finished elevation of the meter lid.
 - iv. Install a 3/4-inch pipe through the hole in the bottom of each setter at least 18-inches long to stabilize the meter assembly.



-
- c. Commercial, Industrial & Multi-Family Residential Water Meter Cans
 - i. A minimum 29 7/8 clear space shall be provided for access through the meter can lid.
 - ii. The inside diameter of the can shall be 36 inches and shall be of a white HDPE pipe or black corrugated HDPE pipe.
 - iii. The shut off valve of each 2-inch setter shall measure 24-inches to 30-inches below the finished elevation of the meter lid.
 - iv. Install a 1-inch pipe through the hole in the bottom of each setter at least 18-inches long to stabilize the meter assembly.
 - d. Water Meter Vaults 4 to 6 inches and Larger
 - i. Water meter vaults for sizes 4 to 6 inches shall be installed in a vault as shown in the APWA Standard Details as amended by the City.
 - ii. Vaults for water meters larger than 6 inches shall be reviewed and approved by the City Engineer on a case-by-case basis.
4. Taps
- a. Both installation of tapping sleeves and the tapping of an energized water main shall be performed by the Developer, after approval is received by the City Engineer and after fees are paid. A City inspector shall be present for the tapping of all energized water mains.
 - b. A 3-foot minimum separation is required between service taps, and between a service tap and a pipe connection on a main water line.
 - c. A double strap lead free brass or stainless-steel saddle shall be installed on newly installed water service taps.



- d. Service taps are prohibited on any line primarily designed to service fire sprinkler systems and/or fire hydrants.
- e. Taps
 - i. The Contractor shall make all taps from the City's operational water system.
 - ii. The Developer is responsible for preparing application and payment of all applicable fees prior to taps being made.

E. Water Quality Division

- 1. Water lines shall be disinfected in strict conformance with AWWA, APWA, and the City's "Flushing and Disinfecting Procedures".
- 2. Notify the City Construction Inspector when samples are ready to be taken to verify disinfection of water lines. The City Construction Inspector must be present and will collect samples in strict conformance with AWWA, APWA, and the State of Utah Standard Specification. The Contractor is responsible for all cost to analyze water samples. Water samples will be processed by Bear River Health Department (BRHD), the Contracting Agency is Nibley City, and it is the responsibility of the Developer to maintain an account in good standing with BRHD.

F. Pipe Materials

- 1. Standard material for water lines located within a City right-of-way or PUE shall be per the City Approved Materials List and installed per this manual, City Standard, ASTM D2774, and AWWA / APWA Standard Specifications and Details as amended by the City as applicable.
- 3. Private Water lines located within private property and not within a City right-of-way, PUE, or water line easement shall be constructed to City Standards and may be of blue C900 PVC Class 305 pipe (DR14).
- 4. PVC is the preferred pipe material for Nibley City unless prior authorization is obtained by the City Engineer and Public Works Director. For all concrete cylinder pipe, ductile



iron pipe, or other metallic pipe installations, soil corrosivity tests shall be conducted and reported in accordance with the American Ductile Iron Pipe Research Association. Reports shall be filed with the City Engineer.

G. Locating Water Lines

1. Water lines shall not directly connect to sewer mains or secondary water lines, shall not be constructed in the same trench, and shall maintain a minimum 10 feet of horizontal separation and 1.5 feet of vertical separation above said lines. Where a water main and sewer line cross, the water main shall be at least 18-inches above the sewer line. Separation distances shall be measured edge-to-edge (from the nearest edge of the facilities).
2. Where conditions prevent adequate horizontal and vertical separation between a water line and a sewer and/or secondary water lines, the water line shall be constructed of welded HDPE (minimum Class 250) extending 10' on either side of the crossing. The line to be connected on either end with flanged connections. More restrictive State of Utah codes may prevail.
3. Where a new sewer force main crosses under an existing water main, all portions of the sewer force main within 10-ft horizontally of the water main shall be enclosed in a continuous sleeve.
4. When a new water main crosses over an existing sewer force main, the water main shall be constructed of pipe material with a minimum rated working pressure of 305 psi (DR14).
5. Where basic separation standards as outlined in subsections G.1 and G.2 above cannot be met, an exception to the rule can be applied for with additional mitigation measures to protect public health, in accordance with Utah R309-105-6(2)(b).
6. Separation of water and electrical, gas, communication lines, or other dry utility lines shall be no closer than 3 feet unless specifically approved in writing by the City Engineer and the utility owner.



-
7. Locating Water Lines within City rights-of-way
 - a. Rights-of-way and/or utility easements shall be dedicated to the City prior to the City accepting ownership.
 - b. Water line location in rights-of-way shall be centered on easements unless otherwise approved by the City Engineer.
 8. Survey staking shall be set for all trenching of waterlines 12 inches or greater in diameter.
 9. Locating Water Lines within Easements
 - a. A water line shall not be installed unless the property owner has granted all necessary easements and rights-of-way to the City.
 - b. All water lines which cross open areas, or any area outside a dedicated right-of-way shall be located within a minimum 20-foot-wide water line easement that is dedicated to the City.
 - c. Easements wider than 20 feet will be required if multiple utilities are co-located, or if additional area is required for maintenance equipment access due to the size and/or depth of the lines.
 - d. No structures of any kind shall be constructed or placed within or over a utility easement except utilities, wire (or removable section-type) fencing, wood chips, decomposed granite, grass, or asphalt paving.
 - e. Easements shall at all times be clear and accessible to City service equipment such as trucks, backhoes, etc. Easements shall be accessible from City rights-of-way or other City owned easements.
 - f. Easements shall be dedicated prior to the commencement of construction activities.
 10. Locating Water Lines in Areas not Accessible by Normal Excavation Methods



-
- a. All pipe constructed in inaccessible areas must be welded HDPE extending 10-feet before and after the section.
11. Surface Water Crossings, whether over or under water, shall follow State of Utah R309 rules and have prior approval from the City Engineer on a case-by-case basis. General requirements are as follows:
 - a. The pipe shall be adequately supported and anchored, protected from damage and freezing, and accessible for repair and or replacement.
 - b. All piping crossing a surface water, whether under or over water, shall be pressure tested prior to commissioning the waterline into service.
 - c. For underwater crossings:
 - i. A minimum cover of 2-feet or greater is required.
 - ii. When crossing water courses greater than 15 feet in width, provide mechanical joint restraints for piping within the crossing and flexible joints at both edges of the water course.
 - iii. A means shall be provided, such as a sampling tap, not subject to flooding, to allow for representative water quality testing on the upstream and downstream side of the crossing.

H. Cover and Bedding Requirements

1. Water mains and services shall have a minimum cover of 60 inches over the top of pipe to top of finished grade.
2. Cover for water mains shall be measured from existing or proposed finished grade of pavement or natural ground, whichever measurement is greater and results in adequate pipe protection during construction.
3. The proposed depth shall be clearly noted in each construction plan sheet. Any changes in depth required to avoid conflicting utilities, etc., shall be noted.
4. When ACP or other poor condition water lines are exposed during construction, the water line shall be removed to the



nearest joint and replaced with PVC (minimum Class 305 (DR14)) with restrained joints.

I. Pressure Requirements

Pressure extremes in water systems result in potential for contamination to enter the network. Low pressures in the water system may allow polluted fluids to be forced into the system. High pressures may cause ruptures or breaks in some elements of the network.

1. Engineers designing domestic water systems shall design to 20 psi under fire flow conditions as the minimum basis of design for pressure at the highest ground level to be served (highest finished floor elevation). Operating water system pressure during average day scenarios shall be a minimum of 40 psi and shall not exceed 120 psi. Ultimate pressure requirements shall be approved by the City Engineer.
2. All water mains shall be designed for a minimum normal internal working pressure of 305 psi (DR14) plus appropriate allowances for water hammer. Water service piping shall be designed for a minimum internal working pressure of 305 psi plus appropriate allowances for water hammer. Water service piping for Residential structures shall be Polyethylene piping designed for a minimum internal working pressure of 250 (DR 9).
3. Water hammer may produce momentary pressures greatly in excess of normal static pressures, thus increasing the probability of water main failure. Suitable provisions shall be made to protect the system from water hammer.
 - a. Thrust blocking is required on all hydrant tees and 90-degree fittings per APWA plan No 511.
 - b. Mechanical joint restraints designed to prevent movement shall be used on all tees, dead ends, vertical, and horizontal bends, hydrant laterals, valves, etc. For purposes of joint restraints, all in-line valves shall be considered dead ends.
 - c. In addition to use of mechanical joint restraints, an additional 2.0 to 3.0 square foot concrete thrust block



shall be provided at all hydrants, tees, and at vertical and horizontal bends.

4. In cases where greater than the above noted maximum pressures are required for effective operation, all elements of the system shall be designed accordingly. Pressure information for existing water lines may be obtained by having a fire hydrant flow test performed on the existing system.
 - a. A Right-of-Way Permit issued by the City Engineer is necessary to perform the fire hydrant flow test.
 - b. These tests may be performed by a private fire protection company who must certify the results of the tests and submit them to the City Engineer.
 - c. Fire hydrant flow testing shall be arranged through the City and a City Public Works staff shall be present throughout the duration of the test. A minimum of 48 hours' notice shall be given prior to testing.

J. Miscellaneous Requirements and Specifications

1. All new water mains shall be designed in a looped configuration.
2. To provide increased reliability of service and reduce head loss, dead ends shall be minimized by making appropriate tie-ins whenever practical. Where dead ends occur, they shall be provided with a fire hydrant if flow and pressure are sufficient, or with an approved flushing hydrant if fire flows are below minimum fire flow requirements. Flushing hydrants (see Approved Materials List) shall be sized to provide flows that will give a velocity of at least 2.5 fps in the water main being flushed and shall be separated at least 10 feet from sewers and storm drains.
3. Trenching, backfilling, and compacting shall be in accordance with Utah R309-550 and City Standard Specifications unless otherwise specified in this manual. Reuse of excavated trench material is prohibited within public roadways. The material and backfill zones shall be as follows:



- a. For plastic pipe, bedding and backfill material used to surround the pipe shall conform to APWA and City Standards and have a maximum particle size of $\frac{3}{4}$ inch;
 - b. For ductile iron pipe, bedding and backfill material shall conform to APWA and City Standards and shall contain no stones larger than 2 inches; and;
 - c. Trench backfill material above the pipe zone at locations within existing and future roadways shall be 3-inch minus Borrow meeting APWA Standards as amended by Nibley City.
 - d. Clay dams shall be installed every 200 lineal feet of trench in areas where groundwater is encountered. Additional clay dams shall be provided at boundaries of wetlands or other waterways. Clay dams shall extend from the bottom of trench to the bottom of the designed roadway pavement section (borrow). Clay material shall be ensure water does not flow within utility trenches and is of a consistency that allows appropriate placement and compaction.
4. Temporary and permanent water lines that terminate at the end of a cul-de-sac shall have a fire hydrant at the non-connected end. In no case shall a fire hydrant be located in a natural or manmade irrigation or stormwater conveyance, detention or retention basin, sidewalk, or driveway.
 5. No water line shall be deflected or swept (either vertically or horizontally) in excess of the maximum recommended deflection specified by the manufacturer of the pipe or coupling. The appropriate use of bends or offsets shall be used where the maximum deflection is exceeded. Fittings may be required where more than two pipe lengths are deflected.
 6. The minimum clearance under culverts, storm drain lines, or similar facilities shall be 2 feet.
 7. Water lines to be abandoned shall be approved by the City Engineer. Abandoned water lines larger than 6-inches in diameter shall be entirely removed or grout filled the entire length of the pipe.

4.1.5 Valves and Zone Splits



A. General Valve Requirements

1. Valve Specifications

- a. All gate valves shall be resilient seated, solid wedge gate, and shall open left.
- b. Butterfly valves shall be required on water mains 12 inches and larger. Crispin 250 class K-FLO Butterfly valves shall be used- no exceptions.
- c. At selected locations between the City's water zones, special water zone valves shall be installed if not previously existing.
- d. Valve box installations and grade adjustments shall be performed per APWA Standard Details as amended by the City.

2. Spacing

- a. Valve spacing for transmission mains with no branches shall be no less than 1/4-mile and no more than 1/2-mile.
- b. The maximum spacing of valves on distribution mains shall be 800 feet for residential zones and 500 feet in all commercial and industrial developments.

c. Valve Isolation

- i. Shall be installed on all legs of "T" and "Cross" intersection fittings unless otherwise approved / required by the City Engineer.
- ii. The maximum number of valves required to isolate an area is four, with two or three being the preferred number.
- iii. No more than two fire hydrants shall be out of service at any given time due to any given valve closure.
- iv. No more than 30 homes shall be without water due to a single valve closure.



- d. Valves shall be spaced and located such that they are beneficial to the operation and maintenance of the system. The City Engineer shall approve all valve locations.
 - e. Where valves are to be located off of a tee or cross, the valves shall be flanged to the tee or cross. For waterlines located in arterial roadways, valves shall be located outside of the intersections of the arterial roadway.
 - f. Valves shall be provided to allow for the isolation of lines crossing rivers, culverts, storm drain lines, manmade and natural drainage ways, canals, railroads, highways, bridges, airports, etc. as directed by the City Engineer.
 - g. All mains branching from feeder mains or loops shall be valved adjacent to the feeders so that the branch mains can be taken out of service without interrupting the supply to other locations.
 - h. Any water line that will be extended in the future shall have a valve, along with a 13-foot minimum stub and a fire hydrant at the non-connected end.
3. Operation
- a. Only City personnel are authorized to open and close all existing water valves at all times and in all circumstances: flushing, pressure testing, chlorinating, etc.
 - b. Valves that control the Water System Zone Split shall be designated by permanently imprinting the letters “ZS” on the lid.
 - c. Valves intended to remain closed shall be designated by painting those valve covers white and shall be “locked out and tagged out” in accordance with OSHA approved methods.
4. Backfilling and Compaction



- a. The area immediately surrounding any City valve shall be compacted. A test(s) verifying the compaction of the soil around the valve shall be provided to the City for each 3-foot depth of trench backfill, and prior to placement of any portion of pavement section materials (roadbase or asphaltic concrete).
- b. Compaction testing around valves shall be performed as follows:
 - i. A minimum one test per valve per water valve cluster shall be performed unless additional tests are required by the City Inspector. The test(s) shall be performed within 2 horizontal feet of the valve and directly over the water main. Care shall be taken to prevent damage to the pipe and valve during compaction and testing.
 - ii. Additional compaction tests may be required as determined on a case-by-case basis. The need for additional tests will be identified by City Engineer representatives.

B. Underground Chambers

Underground chambers (vaults, manholes, pits, cans, etc.) that house air release valves, meters, PRVs, etc. shall be constructed in a manner that prevents freezing of the infrastructure according to the following:

1. Shall be provided with a drain to daylight if possible. Where not possible, gravel based absorption pits and / or a pump system may be required if the site is subject to flooding.
 - a. Chambers shall not be connected to the sewer system.

C. Air Release Valves

Air release valves shall be installed on all water mains 8 inches or larger unless otherwise required by the City Engineer and as follows:

1. When water line changes from a positive slope to a zero slope or negative slope in primary direction of flow.



2. When vertical alignment changes to undercross or overcross another facility (i.e. utility, canal, etc.), air release valves shall be installed on the upstream (higher elevation) side of the crossing.
3. All air release valves shall be a combination air/vacuum release type per the City Approved Materials List.
4. The open end of air relief vent pipe from automatic valves shall be provided with a #14 mesh, non-corrodible screen and a downward elbow extended to at least one foot above grade.
5. Shall not be directly connected to the sewer.
6. Shall be installed in a vault with a drain to prevent it from freezing.
7. Shall be provided with a shut off valve.

D. Pressure Reducing Valves

1. Transmission and Distribution Lines
 - a. PRVs on transmission and distribution lines shall be rated to maintain pressures between 40 psi and 120 psi within the distribution system and shall be set to the pressure determined by the City Engineer.
 - b. PRVs shall be designed in accordance with the City Standards and APWA standard details as amended by the City.
 - c. Pressure gauges shall be installed on the upstream and downstream sides of the PRV after the isolation valves. Pressure gauges shall be connected to the City's SCADA system for live monitoring of pressure conditions.
 - d. A flow meter shall be located at a distance downstream of the PRV according to manufactures recommendations and shall also be connected to the City's SCADA system for live monitoring of flows through the PRV.



- e. PRVs shall be located in the right-of-way or water easement accessible from the right-of-way.

2. Residential and other Services

The City operates its system from wells and pump stations that commonly have pressures exceeding 80 psi. Changes in demand, supply, and the distribution system also vary the pressure at single family residences.

- a. An individual PRV is required to be placed at each structure.

- E. Zone Splits

The City's water distribution system may be divided into various water zones as defined by the City Master Water Plan. If approved, each zone shall operate as an independent water distribution system. Cross-connections between zones are prohibited.

1. Valves

See the Valve section of this chapter.

2. Special Requirements for Developments Bordering Zone Splits

If a proposed development is located adjacent to a zone split boundary, the Developer shall extend, as necessary, redundant water mains within the development's side of the zone split boundary to close the zone loop.

3. Plans

Plans for water distribution mains adjacent to a zone split boundary shall clearly indicate the different zones involved and the location of the zone split boundary.

4.1.6 Fire Lines and Associated Equipment

- A. Fire Lines

1. Location of on-site fire lines and taps should be determined by the site relationships of the fire department connection, emergency access, and fire hydrant locations. Fire lines sizes



shall be determined by City design criteria and flow test data provided by the Design Engineer for the design of the project. All fire systems that connect to a potable water distribution system shall include a double detector check valve backflow assembly.

2. Fire line designs shall be based on a flow test per the Fire Flow Requirements section of this manual. The drawings shall be of uniform size (24-inch by 36-inch) and shall be drawn to scale. One set of the approved civil water plans shall accompany this submittal. Applicable City and NFPA 24 construction notes shall also be included on the construction drawings.
3. All fire lines shall be dedicated for fire use only. No other water lines or water service lines shall be connected to a dedicated fire line. Installation shall be completed per the City-approved construction plans.
4. All hydrants that are supplied by a private fire line shall be private and shall be owned and maintained by the HOA up to the valve in the street. A fire line is defined as a water line that extends off the City main for the purpose of supplying a fire hydrant and has no services.
5. Private fire line mains shall be installed and inspected per the NFPA 24 Standard, and shall include an isolation valve for each individual fire line.
6. Fire line materials and installation shall meet all requirements of this Standard for public water lines.
7. The Owner shall be responsible for maintenance of all water lines beyond the City meter including service lines and valves, fire lines, backflow devices, etc. For commercial fire lines that are not metered, private maintenance responsibility begins after the valve located at the T in the City's main.

B. Fire Hydrants

1. General Requirements

- a. Fire hydrants and associated bypass assemblies shall be installed as identified in the APWA standard details as amended by the City and this chapter.
 - b. The Developer shall provide the fire hydrant, materials, and all labor required for installation. See Approved Materials List for acceptable hydrants.
 - c. All new fire hydrant installations will be installed per manufacturer's specifications.
 - d. Where the finished grade around existing fire hydrants is changed, an extension kit, installed per manufacturer's specifications, may be used. Refer to the City Approved Materials List for approved products.
 - e. One valve shall be placed between each fire hydrant and the water main.
 - f. Fire hydrant laterals shall be a minimum of 6-inches in diameter. Fire hydrant laterals longer than 60-feet shall be 8-inches in diameter or shall be 6-inches with acceptable hydraulic modeling indicates that required flow and pressures can be maintained by a 6-inch line.
 - g. Valves for fire hydrant connections shall be flanged to the tee.
 - h. Hydrant drains shall be installed with 1-inch gravel pack in quantities as required by the manufacturer and the APWA standards as amended by the City. Hydrant drains shall not be connected to or located within 10 feet of sanitary sewers. Where possible, hydrant drains shall not be located within 10 feet of storm drains.
 - i. All public fire hydrants shall be painted red. See the City Approved Materials List for approved paints.
2. Spacing
- a. The spacing of fire hydrants is to be measured along the street or roadway in which a fire hose would be laid. Generally, this spacing is measured along the curb line.



b. Fire hydrants shall be located outside of street improvements but within the right-of-way or public utility easement. General spacing for fire hydrants shall be:

- i. 500 feet maximum in a single-family residential development.
- ii. 350 feet maximum in a multi-family residential or commercial development unless otherwise allowed / required by the International Fire Code.
- iii. 1,000 feet maximum for transmission mains.
- iv. Fire hydrants shall not be installed on any portion of a dead-end line which is more than 660 feet from a looped water line unless adequate fire flow is available at the hydrant.

(1). Hydrants on temporary dead lines greater than 660 feet may be allowed upon request and approval by the City Engineer.

- v. A fire hydrant shall be located within 150 feet of a commercial building fire department connection (FDC).
- vi. Fire hydrant spacing shall be maintained along required Fire Authority access roads.

3. Locations

- a. Private and public fire hydrants shall be accessible to the Fire Authority.
- b. A 7-foot minimum clearance shall be maintained around the fire hydrant from landscape material with a maturity height exceeding 6 inches.
- c. Fire hydrant protection is required where no curb is present.

4. Backfilling and Compaction

- a. The area immediately surrounding any City fire hydrant shall be compacted per APWA Standards as amended by



the City. Test(s) verifying the compaction of the roadbase around the hydrant shall be provided to the City for each 3-foot depth of trench backfill, and prior to placement of any portion of pavement section materials (asphaltic concrete).

- b. Compaction testing around hydrants shall be performed as follows:
 - i. A minimum one test per hydrant per 3-foot depth of trench backfill shall be performed. The test(s) shall be performed within 2 horizontal feet of the hydrant. Care shall be taken to prevent damage to the hydrant, valve, or water main during compaction and testing.
 - ii. Additional compaction tests may be required as determined on a case-by-case basis. The need for additional tests will be identified by City Engineer representatives.

C. Fire Department Connections

1. General Requirements

- a. FDCs from service lines (4 inches and larger), and all hydrant connections, shall be constructed of PVC (minimum Class 305 (DR14) or equal) to the supply line.
- b. All FDCs shall be located in a visible location and shall have an unobstructed access, as approved by the Fire Authority.
- c. FDCs shall be located and arranged so that the hose can be readily attached without obstructions.
- d. FDCs shall be installed on the customer side of the water double detector check valve and shall be painted red.
- e. Signage for FDCs shall be used if the FDC is not easily visible and shall be in conformance with the most currently adopted Fire Code.



- f. There shall be a minimum of 18 inches to the bottom and a maximum of 48 inches to the top of the FDC.
- g. Fire risers and FDCs located at the building do not need to be co-located.

D. Fire Flow Requirements

- 1. Water distribution facilities shall be sized to deliver a minimum fire flow of:
 - a. Minimum Fire flows to commercial, industrial, and multi-family residential properties shall be determined by the Fire Authority.
 - b. 1,500 gpm to 1- and 2-family dwelling unit residential properties.
- 2. Fire flow for buildings with approved automatic sprinkler systems shall be determined based on the requirements of the Fire Code.
- 3. Fire flow tests are valid for a period of six months, unless a known significant change has been made to the City's system or private water system within the 6 month period.

E. Fire Equipment & Storage Facilities

- 4. When required by the City Engineer, double detector check valve backflow assembly is required on all fire line connections to a City water main. Information on backflow prevention may be found in the Cross-Connection Section of this chapter.

4.1.7 Cross-Connection Control

It shall be the responsibility of the City to protect the public water system from health hazards and non-health hazards by the implementation of a cross-connection control program. The program shall consist of inspection by the City Public Works Department and implementation of a backflow prevention and maintenance program, as outlined in the "Manual of Cross-Connection Control" published by USC.



All cross-connection (backflow) devices shall conform to the State of Utah adopted codes.

A. Implementation

1. Air-gap separation shall be required for developments where entry is or will be restricted and cross-connection inspections cannot be made with sufficient frequency or can only be made on short notice. Air-gap separation shall be required in, but not limited to, areas where the following high-hazard conditions exist:
 - a. Public water system is used to supplement secondary water.
 - b. Wastewater is pumped and/or treated.
 - c. Hazardous substances are handled or stored.
 - d. Irrigation systems exist into which fertilizers, herbicides, or pesticides could be injected.
 - e. Unapproved water supply exists which is interconnected with the public water system.
 - f. As required by DDW, or the City Engineer.
2. RPP (or at times DC Valve Assembly backflow prevention) devices shall be required in locations where air-gap is not required, or where entry is not restricted and cross-connection inspection can be made with sufficient frequency or on short notice. Specific uses of these backflow prevention devices are as follows:
 - a. An RPP backflow prevention device may be installed on all lines that connect to the City's potable water system but shall be installed at all connections in which a double check detector backflow prevention device is not permitted.
 - b. Double check valve assembly backflow prevention devices may only be installed on dedicated fire lines that supply fire flow to a structure. DC assemblies shall not be installed in the following situations:



- i. When a chemical is used in the fire suppression system.
- ii. When an on-site private storage tank for fire suppression is located on the premises.
- iii. When an on-site booster pumping system is located on the fire line or private storage tank.

3. Detection Assemblies

- a. RPP detection assemblies may be used on all fire suppression systems but shall be used on all private waterlines that tap into the City's potable water system with the exception of fire lines that do not. RPP detection assemblies shall be required on all Class V and VI fire sprinkler systems. An RPP detection assembly shall also be required when any hazardous or nonhazardous solutions are added to the fire sprinkler systems or used as part of the fire protection system.
- b. DC detection assemblies may be used on all nonresidential fire sprinkler systems where the City's potable water supply is used. A DC detection assembly may be considered for fire sprinkler systems in residential dwellings that are constructed with approved potable water piping and materials. A DC detection assembly may be used on Class I, II, III and IV fire protection systems.

B. Installation

The Owner, at their own expense, shall purchase, install, operate, certify, and maintain any approved backflow prevention device required by the City.

Installation of approved backflow prevention devices shall be as follows:

1. All backflow prevention devices shall be constructed with a security enclosure that is heated during cold weather.
2. An air-gap separation (referred to as a swing connection) shall be located as close as practical to the user's connection at the meter. The piping between the user's connection and the



receiving tank shall be entirely visible. The air-gap separation shall be at least twice the diameter of the supply pipe, measured vertically from the flood rim of the receiving vessel to the supply pipe. In no case shall this separation be less than 1 inch.

3. RPP and DC Valve Assembly backflow prevention devices and detection assemblies shall be constructed in a manner that protects from freezing.
 - a. RPP and DC Valve Assembly backflow prevention devices and assemblies shall be installed according to State of Utah requirements and in a manner where it is accessible for testing.

C. Maintenance

Maintenance of backflow prevention devices shall be as follows:

1. Backflow prevention devices shall be tested and recertified every year and immediately after installation, relocation, or repair. Devices shall not be placed in service unless they are functioning as required.

4.1.8 Secondary Water Systems

Subdivisions that construct pressurized secondary water systems to provide irrigation water lots shall comply with the requirements in this code regarding the construction of such systems.

A. Materials

1. Secondary water system shall be constructed of PVC or HDPE pipe rated for the 25% greater pressure than the design pressure of the system.
2. Pipe shall be purple in color and shall be marked with purple non-potable water marking tape and tracer wire.

B. Systems of City Water and Secondary Water



1. All new properties within a secondary water subdivision shall be upfitted with a swing check connection that requires a physical gapped disconnect from the secondary water system for connection to the City potable water system.
2. IN NO CASE SHALL THE SECONDARY WATER SYSTEM BE PHYSICALLY CONNECTED TO THE HOUSE IRRIGATION SYSTEM AT THE SAME TIME THE CITY'S POTABLE WATER SYSTEM IS CONNECTED TO THAT SAME HOUSE IRRIGATION SYSTEM. THE IRRIGATION SYSTEM SHALL BE CONSTRUCTED SO THAT ONLY THE CITY OR THE SECONDARY SYSTEM IS CONNECTED AT ANY GIVEN TIME

C. Ownership

1. Secondary water systems are privately owned and maintained generally by a home owners association. The City is not responsible for operation and maintenance needs related to these systems.

4.2 Water Main Flushing and Disinfection Guidelines

4.2.1 Regulatory Standards

Nibley City requires that all contractors working in the City adhere to the following guideline for new water main disinfection to prevent contamination of the City's potable water system. The disinfection of all water mains shall be in compliance with AWWA C651-14, the current edition of Utah APWA 33-13-00 Specifications, and this guideline.

Personnel performing flushing and disinfection procedures shall be properly trained and be familiar with AWWA Standards. This standard was written for public and private water lines connected to the Nibley City potable water system. Flushing and disinfection of service lines and internal building lines shall adhere to flushing and disinfection guidelines and standards in the applicable building code.

4.2.2 Valve Operation

At no time will contractors be permitted to open or close any valve tied into the City's water system. Only authorized City personnel can operate these valves for any purpose, which may include disinfecting, flushing, placing a new water main into service, and placement of water meter cans. Once a new main is connected to



the City's water supply, only authorized City personnel are permitted to close valves for the purpose of isolating water lines to facilitate construction or emergencies. Contractors shall coordinate operation of valves with the City Inspector assigned to the project. Operations which require opening or closing of valves shall be scheduled with the Public Works Department through the City Inspector a minimum of 48 hours prior to the work being performed.

If an emergency shutdown is required, call the Nibley City Public Works Department at 435-753-4413 day or night.

4.2.3 Isolation of New Water Mains

As identified in AWWA C651-14, the new main shall be isolated from the active distribution system by physical separation until disinfecting water has been flushed out and satisfactory bacteriological testing has been completed. Water needed to fill the new main for testing and flushing purposes shall only be potable City water, supplied through a temporary flushing / disinfection connection as identified in Figure 1 of AWWA C651-14.

4.2.4 Protection of Pipe, Valves, and Fittings

At all times, the Contractor shall protect valves, fittings, and the interior of pipe against contamination. Stockpiled material shall be stored off the ground to minimize the entrance of foreign material and mud. During placement, openings shall be covered with watertight plugs at the close of the day's work or during short stoppages of work such as rest breaks. If at any time after placement, stormwater enters the pipe, then corrective measures shall be taken per AWWA C651-14 section 5.1.1.3.

4.2.5 Loading the Main for Pressure and Leak Testing

Once the water main and all appurtenances have been installed and the Inspector has received confirmation that the trench backfill has passed compaction requirements, the City will permit the main to be loaded for testing. Section of main greater than ½ mile in total pipe length shall be broken up into two separate tests unless otherwise approved by the City Engineer and/or the Public Works Director. The Contractor shall utilize a reduced pressure type backflow prevention device with a metering device to supply potable water through a temporary connection to the new main from an existing City water source. The device shall be tested and certified by a State Certified Tester prior to use and anytime the device has been repaired or maintenance performed. As a minimum, the device shall be certified within one year of use. A copy of the certification shall be given to the City Inspector and a copy shall be kept on site attached to the device at all times.



No device shall be connected to the City source until approved by the City Inspector and shall be immediately removed once the bacteriological sampling has been completed. All pipe and connectors between the existing City main and the backflow device shall be disinfected per AWWA C651-14 prior to use. The device shall be physically separated from the new main during hydrostatic pressure testing. Valves shall be closed at the end of each shift and when not in use.

4.2.6 Flushing

The City requires that mains be cleared of all debris and soil that may have accumulated during construction prior to starting the disinfection process. The most practical way to achieve this is to flush the main. Only potable City water can be used to fill and flush potable water lines. From the point of the temporary tie in, potable water from the City's system will be utilized to flush the new main. The main shall be flushed at a minimum velocity of 3 feet per second. The Contractor should refer to AWWA AWWA C651-14 Table 3 to determine the inlet and outlet pipe size requirements to achieve the required velocity. Once flushed, the Contractor may continue with disinfection of the main. At least 48 hours prior to the filling and/or flushing of any potable water line, the Contractor must contact the City Inspector to coordinate with the Public Works Department the use of potable water.

4.2.7 Disinfection of Mains

Chlorination of all water mains shall be per AWWA C651-14. The method of chlorination used by the Contractor shall be approved by the City Inspector prior to use. The Contractor is responsible for supplying equipment such as a pitot gauge, meter, or similar devices to verify proper chlorination procedures are performed per standards.

The water shall be chlorinated so that after a 24-hour holding period in the main, there will be a minimum free chlorine residual of 10 mg/L, unless at any time after placement, stormwater enters the pipe, then corrective measures shall be taken per AWWA C651-14 section 4.3.8 and sampling shall be per section 5.1.1.3. This minimum concentration is to be present at all risers. Each riser is to be flushed to ensure the chlorine solution contacts all portions of the pipe. In the presence of the City Inspector, valves, hydrants, and all other appurtenances that are part of the new system shall be operated while the line is filled with the chlorine solution. At the end of the 24-hour period, the City Inspector will verify that treated water in all portions of the main have a minimum concentration of 10 mg/L chlorine prior to flushing for bacteriological testing.

After confirmation of the 10 mg/L minimum chlorine residual, the Contractor may be permitted to flush the line; flushing shall be coordinated with the Public Works



Department through the City Inspector. Flushing is typically limited to the off-peak usage hours of 10:00am to 2:00pm, or as determined by the City Inspector and the Public Works Department. Flushing shall continue until the replacement water throughout the new pipeline can be proved, by laboratory testing, comparable in quality to the water served to the public from the existing water system. If residual chlorine levels exceed 50 ppm, the Contractor will be required to use a neutralizing agent or diffuser to neutralize the chlorinated water during discharge. Refer to AWWA C651-14 Appendix B.

4.2.8 Bacteriological Testing and Acceptance

After disinfection of the main is complete and the main flushed, the Contractor will schedule testing to verify the absence of coliform organisms and HPC bacteria. The City Inspector shall determine the locations where the Contractor will place the sample risers.

The number of sampling locations shall be as follows:

- Waterlines up to but less than 150 feet in length require one sampling riser installed as near the end as possible;
- Waterlines 150 to 300 feet in length, two sampling risers, one near each end of the line;
- Waterlines 300 to 3,000 feet in length, a minimum of three sampling risers;
- In addition, dead ends on main lines should be represented with a sampling riser;
- If any trench water has entered the main during construction, then additional risers shall be placed to conform with AWWA C651-14, section 5.1.1.3

The Contractor is responsible for hiring an independent lab for the sampling and testing of water in the new main. The lab performing sampling shall obtain samples in the presence of the City Inspector. The lab shall be certified by the State of Utah for testing water quality. All sampling and testing shall be in accordance with the State Standards. The first sample shall be taken within 24 hours of flushing the new main. A second set of samples shall be obtained 24 hours after the first set of samples are taken. A copy of the test results along with a Chain of Custody form shall be submitted to the City Inspector.

4.2.9 Connection of New Main

Once approved by the City Inspector, the Contractor will be required to connect the new main to the existing City water supply. The Contractor shall make all required connections within 3 days of notification. The City Inspector will coordinate the work through the Public Works Department.



Connection pieces shall be disinfected per AWWA C651-14 section 4.10 in the presence of the City Inspector. Once all connections are complete, the City Inspector will arrange for the main to be placed into service.



CHAPTER 5

SEWER SYSTEMS

5.1	General Information	3
5.1.1	Purpose.....	3
A.	Introduction.....	3
B.	Abbreviations.....	3
5.1.2	Ordinance Requirements.....	4
A.	Mandatory Extension	4
B.	Construction Plans	4
C.	Fees & Construction Costs.....	4
D.	Non-residential Discharge	4
E.	Nibley City Code	4
5.1.3	Standards of Design and Construction.....	5
A.	Referenced Standards.....	5
5.1.4	City Policies	5
A.	Design Basics.....	5
B.	Private Sewer Mains	6
C.	EPA Regulation	6
5.1.5	Sewer System.....	6
A.	Requirement to Connect	6
B.	Sewer Pipe Classifications.....	6
C.	Sewer Line Sizing.....	7
D.	Public Sewage Lift Stations	7
E.	Wastewater Design Report	7
F.	Updating The City’s Model	7
5.1.6	Plan Preparation	8
A.	Preliminary Wastewater Report.....	8
5.1.7	Site Plans and Preliminary Plats	10
A.	Plan Layout	10
5.1.8	Construction Plan Requirements.....	10
A.	Reviews and Approvals	10
B.	Plan Review Guidelines.....	10
5.1.9	As-Built Drawings	12
5.1.10	Design and Construction Requirements.....	12
A.	Materials, Construction, and Details.....	12
B.	Hydraulic Design	14
C.	Right-of-Way	17
D.	Easement Requirements.....	18
E.	Sewer Pipe Locations and Separations	18



F.	Sewer Lines Cover and Depth	19
G.	Intersecting Lines.....	22
H.	Items that are not allowed.....	22
I.	Tie-in to Existing System.....	22
J.	Manholes.....	22
K.	Manhole Spacing	25
L.	Service Laterals.....	27
M.	Inspections	31
N.	Force Mains	32
O.	Air Release Valves.....	33
P.	Force Main Cleanouts and Manholes	33
Q.	Water Line Separation	34
R.	Force Main Testing.....	34
5.1.11	Wastewater Treatment	34
A.	Treatment Plants	34
B.	Onsite Treatment (Septic Systems).....	34
C.	Reclaimed Water.....	35
5.2	Nibley City Sewage Lift Station Standards.....	35
5.2.1	Purpose.....	35
5.2.2	Site Selection	35
5.2.3	Lift Station Design.....	35
5.2.4	Sewer Lift Station Design Standards	36
5.2.5	Electrical specifications	38
5.2.6	UAC R317-3-3 - Sewage Pumping Stations.....	39



5.1 General Information

5.1.1 Purpose

A. Introduction

This document provides guidance and minimum design criteria for the modification and construction of sewer systems within Nibley City. It is intended for use in the planning, design, plan preparation, and construction processes. These standards are intended to follow State of Utah (hereafter “Utah”) regulations in assuring that City facilities are reliably capable of collecting, transporting, and treating wastewater generated in the City’s service area. In the event a part of these standards is found to conflict with Utah standards, Utah standards shall prevail.

The City maintains a citywide Wastewater Master Plan that has been developed to ensure that the City’s sewer system develops in an organized manner. Contact the City Engineer for further information regarding latest editions and updates to this Master Plan.

Wherever the language of this document refers to equipment or material to be used, or the language of a standard refers to an Approved Materials List, the “Approved Materials List for Sewer” shall be used. Section 5.2- Nibley City Sewage Lift Station Standards, shall be followed when installing a new lift station. These documents can be obtained from the City’s City Engineer or from the City’s website, www.nibleycity.com.

B. Abbreviations

ANSI - American National Standards Institute
APWA – American Public Works Association
ASTM - American Society for Testing and Materials
AWWA - American Water Works Association
BRHD – Bear River Health Department
EPA - Environmental Protection Agency
HDPE – High Density Polyethylene
gpcd - gallons per capita per day
gpd - gallons per day
gpm - gallons per minute
POTW - Publicly Owned Treatment Work
PUE - Public Utility Easement
PVC - Polyvinyl Chloride
UAC – Utah Administrative Code



UDEQ - Utah Department of Environmental Quality

5.1.2 Ordinance Requirements

A. Mandatory Extension

Sewer Mains of a size required for the development or of a size required by the City shall be extended in all new roadways within a development and within all adjacent roadways to a development unless otherwise approved by the City Engineer. Unless otherwise agreed to in a development agreement, where the City requires larger pipe than what is needed for the development or in a location that isn't necessary to serve the development, the City will participate in the construction of that infrastructure.

B. Construction Plans

Upon development of property for which City water or sewer service is available, the Developer shall submit a plan, prepared by a Professional Engineer licensed in the State of Utah, for the sewer system.

C. Fees & Construction Costs

The Developer shall, at his or her expense, construct all on-site and off-site improvements necessary to serve the development. This includes payment of all required development fees.

D. Non-residential Discharge

The City may require users who have a nonresidential discharge to monitor their discharges and obtain a Wastewater Discharge Permit. The permit may be obtained from the Logan City pre-treatment program and is required to be renewed annually. Permitted industries are also subject to quarterly or monthly inspections, sampling and reporting as required by their permit.

E. Nibley City Code

For more specific information on ordinance requirements, review of the Nibley City Code is recommended.

<https://nibley.municipalcodeonline.com/book?type=ordinances#name=Preface>



5.1.3 Standards of Design and Construction

A. Referenced Standards

The technical specifications shall require that installation be in accordance with the requirements based on the criteria, standards and procedures established by:

1. Utah Administrative Code R309 & R317;
2. Current American Public Works Association (APWA) Standards and Specs as amended by Nibley City;
3. Recognized industry standards and practices;
4. The product manufacturer's recommendations and guidance;
5. The Following codes, as adopted by the State of Utah:
International Building Code, International Plumbing Code,
International Mechanical Code and National Electrical Code;
6. American Society of Testing Materials (ASTM);
7. American National Standards Institute (ANSI);
8. Occupational Safety and Health Administration (OSHA), US
Department of Labor or its succeeding agencies;
9. American Society of Civil Engineers (ASCE); and
10. American Water Works Association (AWWA);

5.1.4 City Policies

A. Design Basics

Sanitary sewers shall be designed to serve the ultimate population density expected in the tributary area. The design must be in conformance with the current City approved Wastewater Master Plan, and as such, shall take future connections into consideration.



B. Private Sewer Mains

Except in planned commercial centers and private drives/alleyways etc., sewer mains shall not be privately owned. Private sewer mains shall not receive discharge from public sewer mains.

1. A Private Utility Agreement must be in place and recorded on the properties describing ownership and maintenance requirements.
2. Sewer service lines and connections thereto shall be privately owned and maintained.
3. Private sewer lines shall meet City Engineering design standards for approval. Privately owned and maintained sewer lines shall not be located within the street right-of-way or a PUE.

C. EPA Regulation

The City is required by the U.S. EPA to develop and implement a program to control discharges that might harm the publicly owned treatment work (POTW). The program establishes local discharge limits for non-residential users and provides for a permitting process based on user discharges and business types. Specific information may be obtained by calling the City Engineer at 435-752-0431. The permit administered through the Logan City pre-treatment program and is required to be renewed annually. Permitted industries are also subject to quarterly or monthly inspections, sampling and reporting as required by their permit.

5.1.5 Sewer System

A. Requirement to Connect

All developments are required to connect to the City's sewer system if located within 300 feet of a City Sewer Main or the property is within a water source protection zone as defined by the Nibley City Code. Where connection isn't feasible according to City Code, onsite disposal systems may be allowed as approved by the City Engineer.

B. Sewer Pipe Classifications



The City's sewer system includes classifications of sewer lines which are determined by use. These classifications are:

1. Building Service or Lateral – This is the line from the building to the public or private Sewer Main or onsite disposal; also called house connection.
2. Sewer Main – A principal sewer line to which Building, Service, or Lateral sewer lines are tributary.
3. Force Mains – A pressurized sewer line that receives sewer flows from a sewer lift station.

C. Sewer Line Sizing

1. All developments shall provide for trunk / main, lateral, and service lines as required to provide sewer service for not only the individual development, but for the ultimate service area, as deemed necessary by the City Engineer.
2. Sewer lines shall be sized to accommodate their ultimate service area. Reference shall be made to the City's Wastewater Master Plan for the sizes and locations of Sewer Mains within the City. The minimum size line for a public main is 8-inch diameter.

D. Public Sewage Lift Stations

The City Wastewater Master Plan has estimated wastewater generation from the entire City. Refer to this plan for information regarding the approved location for public sewage lift stations. Public lift stations in size and location other than those identified in the City Wastewater Master Plan will not be permitted.

E. Wastewater Design Report

At a minimum, Preliminary and Final Wastewater Reports shall be prepared by a Civil Engineer registered to practice in the State of Utah for each development within the City. The cost of said reports shall be the responsibility of the Developer. These reports shall be designed per the requirements of this manual and the City Wastewater Master Plan.

F. Updating The City's Model



Information provided in the City Wastewater Master Plan has been developed based upon the zoning land uses existing at the time of completion. If determined by the City Engineer or if a proposed development changes the land use of an area in such a manner that it significantly impacts the functionality of the City Wastewater Master Plan, the Developer will be financially responsible to update the City Wastewater Model prior to obtaining permits for construction.

5.1.6 Plan Preparation

A. Preliminary Wastewater Report

A Preliminary Wastewater Report regarding the wastewater system for a development shall be provided to the City for nonresidential development and all Preliminary Plat applications that contemplate a phased approach to construction or have greater than 50 lots. The preliminary information provided within this report shall at a minimum calculate that amount of wastewater generated by the development, show the proposed location, sizes, inverts and rim elevations of existing and proposed Sewer Mains, manholes, lift stations, force mains, etc within and adjacent to the site. The report shall include calculations to substantiate proposed sizes are sufficient for the required capacity. The text shall describe the property, identify the wastewater treatment facility that will be accepting flows, and discuss any unique scenarios that may not be obvious by inspection of the plans. The Preliminary Wastewater Report will form the basis of design for each phase of development as it is submitted for approval. It is understood that plans are conceptual in this stage

1. All development projects shall be responsible for determining their specific wastewater system needs. Services for proposed developments shall not be provided at the expense of existing customers. Preliminary and Amended Wastewater Reports shall state this in the introduction.
2. The design of the wastewater system can typically end at the point of connection to the City's existing sewer system. As determined by the City Engineer and/or in cases where a development requires a change to the City's general plan or zoning plan, additional improvements may be required beyond the point of connection to accommodate the proposed project.
3. If a property is desired to be developed which could result in increased line sizes within the project area or in its downstream

receiving sewer lines or would otherwise significantly alter the Sewer Main alignments as shown in the City's current Wastewater Master Plan; the developer shall also be required to reimburse the City for the cost of amending the City's sewer master plan and City-wide sewer model.

4. Calculations should be based on Manning's equations using a Manning's "n" of 0.013, as well as the invert elevations and pipe diameters of all existing and proposed pipes.
5. Wastewater flows generated within the development shall be calculated as specified in the Design Flows section of this chapter.
6. Off-site wastewater flows are included in the City's current Wastewater Master Plan unless newer information is provided by the City.
7. An electronic file containing calculations may be submitted along with the sewer reports but does not replace the need to provide this information in the written report. Common spreadsheet formats compatible with Microsoft Excel are acceptable.
8. Compliance with the current City Wastewater Master Plan for the respective area:
 - a. Each sewer report shall include a map showing the following:
 - i. All proposed onsite and off-site facilities; these include but are not limited to interceptors, sewer lift stations, and force mains.
 - ii. Proposed street locations, parcel boundaries, and proposed lots within each parcel.
 - iii. Contour lines at 2-foot intervals showing the elevation of the land surface shall be provided. If drainage requirements will require extensive grading, then finished grades should also be shown. Sufficient information must be provided to evaluate pipe cover and separation from other utilities.
 - b. A separate area location map shall be provided showing existing and proposed streets, as well as existing parcels surrounding the project to a distance of not less than 1 mile



from the exterior boundaries of the project. The County Assessor's maps can provide the information required to prepare these composite maps.

- c. The scale of all maps must be sufficient to show all required information clearly.
9. When the City Engineer determines that a final design for a phase of development is significantly different than what was approved in the Preliminary Report (ie significant changes the design or layout of the system), the Preliminary Report will be required to be amended at the expense of the Developer requesting the change.

5.1.7 Site Plans and Preliminary Plats

A. Plan Layout

All site plans and preliminary plats shall provide an exhibit that shows and labels the following:

1. All existing wastewater lines, proposed wastewater lines, sizes, slope, and material types.
2. Lift stations and associated force mains.
3. All existing infrastructure shall be shown in dashed screened black line types. All proposed improvements such as wastewater lines, lift stations, and force main lines shall be shown in dark lines.
4. All existing and proposed wastewater line easements.

5.1.8 Construction Plan Requirements

A. Reviews and Approvals

1. All improvement plans which include work within the City shall be submitted for review and approval by City Staff. Plan review submittals are made to the City Engineer.

B. Plan Review Guidelines



No permits for public sewer installation will be issued until the Owner / Developer has provided the necessary easements and rights-of-way. The instruments of dedication must be approved by the City and recorded at the Cache County Recorder's Office. The following paragraphs highlight construction plan requirements pertaining to the preparation of sewer improvement plans which are to be submitted to the City for approval:

1. Plans shall be prepared per the City's construction plan development guidelines.
2. General Construction Notes and Sewer Construction Notes which apply to construction of Nibley City's sewer system are required on each set of construction plans which include work on the City's sewer system or a sewer system which is to be dedicated to the City. These notes are provided within this manual.
3. Sewer line stationing shall be shown along the pipe, monument, or roadway centerline.
4. Protection for sewer / water line crossings shall be shown in both plan and profile. The beginning and ending stations of the protection shall be called out.
5. If a line is to be connected to an existing system, the following note shall be placed on the plans: "Contractor shall verify the location of the existing sewer line before proceeding with trenching."
6. Both slope and elevation shall be shown on all proposed Sewer Main stubs. A profile is required for Sewer Mains.
7. Where sewer lines cross water lines, storm drains, reclaimed water lines or drainage culverts, the relationship shall be shown in both plan and profile and actual separations shall be called out.
8. Sewer line invert elevations shall be called out for all plans showing sewer line construction.
9. The drawings shall show all utility locations, sizes, material types, easements, rights-of-way, and other structural features of the sewer for current and future building construction.
10. Lift station details shall show all invert elevations, structural elevations, existing and finished grades, control setting elevations,

structural design of wet wells and dry wells, valves and piping, surge control devices, pump suction, discharge details, and any other details which will provide a clear understanding of the design.

11. All force main lines shall be shown in profile. Plans and profiles of force mains shall show size, invert and grade elevations, materials of construction, utility location, and any other details which define the force main construction requirements.
12. Private sewer lines shall be noted as such on plans. The responsibility for operation and maintenance should also be called out.
13. Easements of record shall be noted and shown in plan view, including docket and page numbers and / or the Cache County Recorder's number.
14. All plan documents for sewers and / or wastewater treatment works shall be prepared by a Registered Professional Engineer licensed in the State of Utah.

5.1.9 As-Built Drawings

A City-approved set of as-built drawings are required for all sewer system improvements constructed in the City prior to acceptance of the system and start of the 1-year warranty period. If requested by the City Engineer, As-built plans shall be signed and sealed by a qualified professional registered in the State of Utah.

5.1.10 Design and Construction Requirements

A. Materials, Construction, and Details

In selecting pipe material for sewers, consideration shall be given to the chemical characteristics of the wastewater (especially in industrial waste flow areas), the possibility of septicity, exclusion of infiltration, external and internal pressures, abrasion, and similar problems encountered with the established grades.

1. Approved PVC or HDPE may be used for gravity Sewer Main lines and service laterals, between 4 and 15 inches (see Approved Materials List for Sewer). Under certain circumstances, other



material may be considered in a case-by-case basis. Materials and details for Sewer Mains larger than 15-inch diameter will also be reviewed on a case-by-case basis.

2. Pipe materials used for pressurized or forced mains shall be approved by the City Engineer and pressure rated to 1.25 times the working pressure.
3. No sewer lines (Public or Private) other than Service Laterals shall be less than 8 inches in diameter.
4. Pipe material, size, and slope shall not change between manholes.
5. Sewers shall be laid with a straight alignment between manholes. Pipe zone and bedding and backfill shall be untreated base course material Class A or B, Grade $\frac{3}{4}$ in compliance with APWA Section 32 11 23 or $\frac{3}{4}$ inch minus sewer rock.
6. Trench backfill material above the pipe zone at locations within existing and future roadways shall be 3-inch minus Borrow meeting APWA Standards as amended by Nibley City.
7. Clay dams shall be installed every 200 lineal feet of trench in areas where groundwater is encountered. Additional clay dams shall be provided at boundaries of wetlands or other waterways. Clay dams shall extend from the bottom of trench to the bottom of the designed roadway pavement section (borrow). Clay material shall be ensure water does not flow within utility trenches and is of a consistency that allows appropriate placement and compaction.
8. Sewer Lines, including laterals shall be identified by 12 gauge, solid copper tracer wire shall be run with pipe. Locating tape labeled SEWER shall be placed a minimum of 36" above the sewer main or just below the pavement section (pit run for road) if less than 36" above the pipe.
9. Where standard-strength pipe is not structurally sufficient, and sufficient cover cannot be maintained, additional strength must be obtained by using higher class pipe. Special bedding specifications and / or special construction methods may also be required.

10. All types of pipe materials used in design shall have established ASTM, ANSI, or NSF standards of manufacture or seals of approval, and shall be designated for use as sewer pipe.
11. Pavement replacement type and compaction type shall be indicated per City Standards, this manual, and APWA standards, and shall be identified on each sheet.
12. Generally, sewer lines may not be located within zones one and two of a public drinking water system's source protection zones. However, if all requirements of this standard in addition to taking the following precautions in accordance with Utah R309-515, sewer lines may be permitted within zones one and two:
 - a. Sewer lines shall meet conditions identified in R309-600-13(3) and shall be specifically constructed as follows throughout zone one in aquifers classified as protected and zones one and two, if the aquifer is classified as unprotected:
 - i. Sewer lines shall be constructed to remain watertight. The lines shall be deflection-tested in accordance with the Division of Water Quality Rule R317-3. The lines shall be video inspected for any defect following completion of construction and no more than 14-days prior to placing in service.
 - ii. HDPE DR14 (or less) pipe having all joints fusion welded with a PE3408 or PE4710 rating: or,
 - iii. PVC C900 or 905 DR18 (or less). PVC pipe shall be either restrained gasketed joints or shall be fusion welded. Solvent cement joints shall not be acceptable; or,
 - iv. Ductile Iron Pipe with ceramic epoxy lining, polyethylene encasement, restrained joints, and a minimum pressure class of 200.

B. Hydraulic Design

1. Sewer lines shall be designed for the estimated ultimate tributary population. The City Engineer may approve the design for reduced capacities provided the capacity of the system can be readily increased when required. The maximum anticipated



capacity required by institutions, industrial parks, etc. must be considered in the design.

2. Sewer lines shall be designed to flow no greater than three-quarters (75%) full.
3. Sewer lines shall be designed using the criteria identified in the City's Sewer Master Plan. The current Master Plan may be downloaded from the City's website.
4. Sewer line slopes shall be sufficient to maintain a velocity of 2 fps. Calculations are to be based upon Manning's Formula, using an "n" value of 0.013. To prevent abrasion and erosion of the pipe material, velocities exceeding 9 fps should be avoided.
5. Hydrogen sulfide problems must be analyzed in the Design Report and be provided for in the design of the system where required.
6. All velocities should be analyzed under peak hour flow conditions.
7. The following table indicates the minimum and maximum slopes generally considered necessary to obtain desired velocities. Table 5.11-1 shows the minimum slopes which shall be provided; however, slopes greater than the minimum are desirable. Minimum slopes reflect guidelines from the Nibley City Sewer Master Plan. Exceptions require the written approval of the City Engineer:

TABLE 5.11-1 – Minimum Slopes for Sanitary Sewers (n = 0.013)

Pipe Size (inches)	Minimum Slope <i>2.0 fps</i> (ft/ft)
8	0.004
10	0.0028
12	0.0022
15	0.0015

18	0.0012
24	0.0010

8. Flatter Slopes

Slopes flatter than those required for the 2-feet-per-second velocity criterion, may be permitted by the City Engineer and State of Utah standards provided that:

- a. there is no other practical alternative;
- b. the depth of flow is not less than 30 percent of the diameter at the average design rate of flow; and
- c. the design engineer has furnished with the report the computations showing velocity and depth of flow corresponding to the minimum, average, and peak rates of flow for the present and design conditions in support of the request for a variance.

9. Steep Slopes

- a. Where velocities greater than 9 feet per second are attained, special provision shall be made to protect against displacement by erosion and shock.
- b. Sewers on 20 percent slopes or greater shall be anchored securely against lateral and axial displacement with suitable thrust blocks, concrete anchors, or other equivalent restraints, spaced as follows:
 - i Not over 36 feet center to center on grades 20 percent and up to 35 percent;
 - ii Not over 24 feet center to center on grades 35 percent and up to 50 percent;
 - iii Not over 16 feet center to center on grades 50 percent and over.
- c. Where velocities greater than 15 feet per second would be attained, drop manholes may be used to aid in reducing the



velocity. Drop manholes may not be used under any other circumstances unless specifically approved by the City Engineer.

10. Design Flows

- a. The Peak Hour wastewater flow rate shall be used to determine line size capacities based on the Nibley City Sewer Master Plan.
- b. The actual Peak Flows of the Nibley City sewer system vary throughout the system based on flow routing, so one peaking factor is not consistent throughout the collection system. The Nibley City sewer model should be referenced to verify the existing system has adequate capacity to facilitate additional connected flows. The cost to model the designed system shall be paid by the owner or developer.

11. Commercial and industrial capacities shall be calculated and documented by the Engineer or Architect based on fixtures and any expected process or wash down flows. Calculations shall not be considered final until approved by the City Engineer. The Nibley city Sewer Model shall be used to verify the existing system has adequate capacity to facilitate additional connected flows. The cost to model the designed system shall be paid by the owner or developer.

12. The City Engineer will consider other rates of flow for the design if such basis is justified on the basis of supporting documentation.

C. Right-of-Way

1. All City sewer lines shall be located underneath asphalt pavement within a street right-of-way unless otherwise approved by the City Engineer.
2. Sewer lines in local residential streets shall typically not cross street centerline, unless approved by the City Engineer.
3. The outside edge of manhole shall be located at least 2 feet from the street centerline or near edge of curb and gutter.



4. All sewer lines shall be aligned parallel to the property lines or the street centerlines, or as close to parallel as possible.
5. Sewer mains shall not be located under a raised street median or stormwater basin unless otherwise approved by the City Engineer.

D. Easement Requirements

1. No sewer line shall be installed in an easement unless the City Engineer has approved the placement of the line in an easement and the property owner has dedicated the necessary easements.
2. If approved, sewer lines outside of public rights-of-way shall be placed in easements not less than 20 feet wide. A 30-foot wide easement is required for lines deeper than 10 feet; for pipes with diameters greater than 16 inches the City Engineer shall determine the required easement width. Sewer lines shall be accessible from a public right-of-way or other accessible public easement at all times.
3. Easements larger than 20 feet in width may be required if other utilities are co-located in the easement or if additional area is needed for maintenance and equipment access due to the size and/or depth of the lines.
4. Easements shall be free of obstructions, shall not be located in a fenced area, and shall at all times be accessible to City service equipment such as trucks, backhoes, etc.
5. Easements shall be dedicated prior to obtaining any sewer construction permit.

E. Sewer Pipe Locations and Separations

1. Service Lateral Locations
 - a. The engineering plans shall contain the following statement: “If a sewer service falls under a driveway during the construction of a home, it shall be relocated or a cleanout shall be installed at the outside PUE line, at the City’s discretion”.
2. Separation of Water and Sewer Lines

Caution should be taken in the design and construction of sewer lines to protect all water supplies from wastewater contamination. To minimize the potential of contamination, the Engineer shall design the horizontal and vertical separation of water and sewer lines in accordance with State Codes, City Standard Specifications and City Standard Details.

- a. The minimum separation between sewer lines / sewer Service Laterals and water lines / water service lines shall be 2 feet vertical and 10 feet horizontal, all as measured from nearest wall to nearest wall.

3. Separation from Gas Lines

The minimum horizontal distance from a sewer line to a parallel gas line shall be 3 feet, from nearest edge to nearest edge.

4. Separation from Water Course

- a. Sewer lines crossing less than two feet below a water course or under large structures such as box culverts and bridges, shall require the use of HDPE carrier pipe housed within welded steel or HDPE casing pipe.

5. Sewers crossing over water lines, other utilities and culverts must be a minimum of 18-inches above, as measured from nearest edge to nearest edge. The crossing shall be arranged so that the sewer joints will be equidistant and as far as possible from water main joints.

F. Sewer Lines Cover and Depth

1. All private, public, and service wastewater lines shall have a minimum of 4 feet of cover, as measured from finished ground at the property line or easement line. A sewer line may be installed with less than 4 feet of cover over the top of the pipe with special written approval from the City Engineer. A private sewer lateral may have 36-inches of cover.
2. Depths of sewer trunk lines identified in the City's Wastewater Master Plan shall be of sufficient depth to follow the design of the Wastewater Master Plan, per City Engineer.
3. All sewer lines that extend across / beneath areas that can be inundated with water or are within the groundwater table shall be

constructed to prevent damage to the pipe due to scour, freezing, and floating. All sewer lines and manholes shall be water tight so as to eliminate all infiltration of the surrounding water.

4. All sewer pipe approved within a water course shall be constructed of HDPE material that extends 10 feet each side and shall be constructed:
 - a. 2-feet below the 100-year scour limit.
 - b. 1-foot below a bedrock surface.
 - c. A minimum 3-feet below any other material. Cover in excess of 3-feet may be required in waterways having a high erosion potential.
 - d. As close to perpendicular to stream flows as possible.
 - e. Sewers entering or crossing streams shall be constructed of cast or ductile iron pipe with mechanical joints.
5. Sewers shall be installed at a depth sufficient to ensure gravity drainage of wastes from each service. Sewer design shall ensure adequate drainage from the ultimate drainage area and shall allow for the future extension of service to adjacent parcels.
6. All sewer lines shall be designed to absorb superimposed live loads and backfill overburden without damage to the pipe material, and without adversely affecting the hydraulic characteristics of the pipe. The Engineer shall specify minimum depths of cover to be provided during the construction of roadways or other facilities affecting cover over the sewer line.
 - a. PVC pipes shall be a minimum SDR 35 class pipe for depths up to 15 feet and a minimum SDR 26 for depths 15 to 30 feet.
 - b. HDPE pipes shall be a minimum class of DR-11.
7. If approved by the City Engineer, shallow sewer lines shall be evaluated for the requirement of insulation against freezing.
8. Sewer Lines, including laterals shall be identified by 12 gauge, solid copper tracer wire shall be run with pipe.



- a. All splices shall be with grease filled wire connectors.
 - b. At vault and manhole locations, wires shall be coiled inside and secured in a location that is readily accessible near the entrance to allow access to the wires without completely entering the vault and to protect the wire from dislodging and falling into the sewer flow line. Tracer wire shall run up the sides of each manhole or vault and extend into the manhole cone just below the top by means of a drilled hole or saw cut.
9. Locating tape labeled SEWER shall be placed a minimum of 36" above the sewer main or just below the pavement section (pit run for road) if less than 36" above the pipe.
10. Trenching, backfilling, and compacting APWA and City Standard Specifications unless otherwise specified in this manual. Reuse of excavated trench material is prohibited within public roadways. The material and backfill zones shall be as follows:
- a. For plastic pipe, bedding and backfill material used to surround the pipe shall conform to APWA and City Standards and have a maximum particle size of $\frac{3}{4}$ inch;
 - b. For ductile iron pipe, bedding and backfill material shall conform to APWA and City Standards and shall contain no stones larger than 2 inches; and;
 - c. Trench backfill material above the pipe zone at locations within existing and future roadways shall be 3-inch minus Borrow meeting APWA Standards as amended by Nibley City.
 - d. Clay dams shall be installed every 200 lineal feet of trench in areas where groundwater is encountered. Additional clay dams shall be provided at boundaries of wetlands or other waterways. Clay dams shall extend from the bottom of trench to the bottom of the designed roadway pavement section (borrow). Clay material shall be ensure water does not flow within utility trenches and is of a consistency that allows appropriate placement and compaction.
11. Sewer lines to be abandoned shall be approved by the City Engineer. Abandoned sewer lines larger than 6-



inches in diameter shall be entirely removed or grout filled the entire length of the pipe.

G. Intersecting Lines

1. When the diameter of a sewer line changes within a manhole, the inside crown elevations of the two pipes shall match.
2. Manholes with the through-line having a change in direction greater than 30 degrees shall have a minimum 0.10-foot drop through the manhole.
3. For manholes with a line intersecting the through-line, the intersection line invert shall be 0.10 feet above the flow line of the through-line.
4. The maximum angle between the upstream sewer line and downstream sewer line shall be no greater than 90 degrees.

H. Items that are not allowed

1. Horizontal curvilinear sewers will not be accepted.
2. Aerial Crossings.

I. Tie-in to Existing System

1. Construction plans shall call for the Contractor to tie-in new work to the existing, active system only after completion of the new work, and with specific approval of the Public Works Inspector to make the tie-in.

J. Manholes

1. Materials and Details
 - a. Manholes serving only 10-inch and smaller through lines and no other connection may be as small as 4 feet in diameter. All other manholes shall be 5 feet in diameter.
 - b. Manhole frames and covers shall be Class 35, ASTM A48 as more fully identified in the approved materials list.

- c. All manholes and rings shall be constructed of concrete or polymer; plastic substitutes will not be permitted.
- d. All manholes and risers shall have a smooth interior finish.
- e. The interior of manholes receiving discharge from forced sewer mains shall be entirely constructed of concrete with anchored HDPE liner (Perfect Lined Manhole by Geneva). Upon approval by the City Engineer, existing manholes may be coated with a City approved corrosion resistant coating. See the City Approved Materials List for Wastewater.
- f. Reinforced concrete adjusting rings shall have a total height of no more than 12 inches but no less than 6 inches.
- g. Eccentric cones with access openings shall accommodate installation of a 25-inch diameter iron lid with a 6-inch frame. Flat manhole caps/lids and low profile frames are not allowed.
- h. All manholes shall be provided with ladder/steps for accessing the manhole.
- i. The flow channel through manholes should be made to conform in shape and slope to that of the sewers. The depth of flow channels should be between one-half and three-quarters of the diameter of the sewer. Adjacent floor area should drain to the channel with the minimum slope of 1 inch per foot.
- j. Upon request of the City Engineer, sewer manholes shall be tested per ASTM C-1244-93.
- k. The flow channel through the manhole shall be precast or steel-trowel finished to conform in shape and slope to that of the sewer lines. The manhole shelf shall be brush or broom finished, with a slope of one inch per foot. The manhole bottom should be filleted to prevent solid depositions and channeled to ensure satisfactory flow to the lower invert.
- l. Manholes shall be watertight and protected from storm water and groundwater infiltration.
- m. Manholes shall typically not be located in drainage areas, detention/retention basins, or below the FEMA 100-year

floodplain elevation (when located within a Flood Hazard Area).

- n. If the City Engineer approves a design allowing manholes to be located in a floodplain, bolted water-tight manhole covers, or water-tight manhole inserts shall be used to prevent inflow. The manhole shall be designed such that infiltration or exfiltration cannot occur. Providing for the elimination of infiltration and/or exfiltration is the Design Engineer's responsibility in the design of the system.
- o. Manholes located in undeveloped or landscaped areas subject to flooding or irrigation must be installed at least 18-inches higher than finished ground elevation. The manhole shall be provided with a water tight solid locking or bolted manhole cover.
- p. Locked or bolted manhole covers may be desirable in isolated easement locations or where vandalism may be a problem as directed by the City Engineer.
- q. Manhole covers located within a sidewalk, trail, or other walking surface shall be provided with solid locking or bolted manhole lids.
- r. Manholes shall be cast with boot style pipe connections.
- s. Two layers of mastic seal shall be installed per joint. See the Approved Materials list for approved products.
 - i. Mastic Seal shall be heated to within the manufacturer's recommendations prior to placement. The cone or barrel shall be placed on the mastic before temperatures fall below the manufacturers recommendations.
- t. All exterior manhole joints shall be wrapped with a joint seal prior to backfill. See the Approved Materials list for approved products.
- u. "Doghouse" manholes are generally prohibited in areas with high ground water. Where conditions prohibit other options, doghouse manholes located in areas of high groundwater shall have joints designs such that infiltration is prevented. Use of hydrophilic sealant at

doghouse manhole bases and at pipe entry points is required.

- v. Manholes shall be inspected at final acceptance and again at 1-year warranty inspection. Contractor is responsible to clean manholes and address/repair any observed infiltration at each inspection and longer if construction continues beyond the 1-year warranty period.
- w. Electrical equipment installed or used in manholes shall conform to appropriate National Electrical Code, as adopted by the State of Utah, requirements.

K. Manhole Spacing

1. Spacing requirements

- a. Manholes are required at all changes in grade or direction and changes in pipe size, at all changes in alignment, and at locations necessary to ensure the sewer line stays within a paved area of a street or right of way.
- b. Unless otherwise specially approved in writing by the City Engineer, Maximum manhole spacing shall be:
 - i 400 feet for 8 to 10-inch sewer lines.
 - ii 500 feet for sewer lines larger than 10-inch.
- c. Manholes in City streets must be located near the center of a traffic lane. Manholes should not be located in bike trails, equestrian trails, sidewalks, or crosswalks.
- d. Cleanouts
 - i Cleanouts are not allowed in the City right- of-way or dedicated easement. If there are services between the last manhole and the end of the line, a manhole shall be required at the end of the line.
 - ii A double cleanout shall typically be located within the building envelope.

- iii Cleanouts shall be placed no more than 30-inches outside of structures served and constructed every 100 feet on a sewer Service Lateral. Other Cleanout locations shall be in accordance with the IPC.
 - e. Manholes on boundaries of the subdivision shall have stubs with shaped inverts in appropriate directions for future connections.
 - f. Centerline stations and offsets shall be shown on all manholes.
 - g. A sewer manhole shall be required at the upstream end of a cul-de-sac. All manholes shall be located in such a manner as to provide easy access for the City's cleaning equipment.
- 2. Intersecting Lines Within Manholes
 - a. Manholes with lines intersecting at angles more than 30 degrees shall have a minimum 0.10-foot drop across the manhole.
 - b. When sewer lines of differing sizes enter the same manhole, the crowns of all pipes shall match (ie set to the same elevation).
 - c. In large trunk lines, inverts at junctions should be designed to maintain the energy gradient across the junction and prevent backflow.
- 3. Drop Manholes
 - a. Drop manholes may not be used for through line applications unless specifically approved in writing by the City Engineer.
 - b. Manholes receiving discharge from pressurized sewer lines (forced mains) shall be provided with 60-inch diameter manhole constructed with drop connections in accordance with APWA detail 433 (Alternate 2) as modified by Nibley City. The drop (vertical pipe) for pressure sewer connections shall occur inside the manhole.
 - c. The interior surface of drop manholes receiving discharge from pressurized sewer lines shall be entirely constructed of concrete with anchored HDPE liner (Perfect Lined Manhole



by Geneva). Upon approval by the City Engineer, manholes may be coated with a City approved corrosion resistant coating. See the City Approved Materials List for Wastewater.

- d. A drop connection per APWA detail 433 (Alternate 2) as modified by Nibley City is allowed for connections that intersect with the Sewer Main or trunk line. The drop (vertical pipe) for gravity sewer connections shall occur outside the manhole.
 - i Where the drop is less than 18 inches, the invert should be filleted and channelized with concrete rather than construction of a drop.

4. Monitoring Manholes

- a. The City shall determine whether or not a commercial or industrial sewer service will be required to have a monitoring manhole to test the flow and composition of their sewage. As a general rule, commercial / industrial sewer users with a projected water consumption of 25,000 gpd or greater, sewer discharges of a categorical industrial nature, or other situations as deemed necessary by the City Engineer, shall be required to have a monitoring manhole.
- b. Sewer Service Laterals with diameters smaller than 6 inches that feed into monitoring manholes shall have no taps or bends for two pipe lengths upstream and one pipe length downstream.
- c. Design details for monitoring manholes on sewer Service Laterals 6 inches or larger, or with a peak flow greater than 40 gpm, shall be approved by the City.
- d. Monitoring manholes shall be located in a minimum 20-foot-wide PUE which extends from a 20-foot radius around the manhole to the existing public sewer. The monitoring manhole shall be accessible at all times to monitoring crews and vehicles.

L. Service Laterals

1. Service Lateral Connections

- a. Each individually owned unit or building shall have a separate sewer line connected to the public sanitary sewer system unless otherwise approved by the City Engineer.
- b. Old Building Sewers may be used in connection with new buildings. Old Building Sewers shall be inspected by closed-circuit television (CCTV) methods acceptable to the City. Any defects discovered during televised inspection shall be corrected at no cost to the City. After correction of defects has been completed, affected sewer sections shall be re-televised at no cost to the City. A flash drive containing video of all televised inspections shall be provided to the City prior to final acceptance of the sewer. All televised inspections shall comply with the City’s “Sewer Television Inspection Standards”.
- c. Sewer services to residential households do not constitute a sewer project and will generally not be required to submit construction plans to be reviewed and approved by the City Engineer.
 - i All permits shall be secured and fees shall be paid before any work is commenced on a sewer connection.
 - ii All Service Laterals shall be constructed by a licensed Contractor at the expense of the Developer / Owner. Prior to the construction of any Service Lateral, the Contractor shall contact City Inspections for inspection services not less than 24 hours prior to tapping.
- d. New sewer Service Laterals shall be constructed per the City standards and APWA Standard Details and specifications.
- e. A three-foot minimum separation between Service Lateral connections on a Sewer Main is required.
- f. All Service Laterals shall be dimensioned and stationed on the plans. Typical dimensions to water Service Laterals shall be shown.
- g. Service Laterals installed for future connection shall be marked.



- h. When installed, all Service Laterals must be perpendicular to the Main. The flow line of the sewer Service Lateral shall enter at 45 degrees to the center of the main and cannot be more than 4 inches below the crown of the line to be tapped.
 - i. No Service Laterals will be made directly into manholes or sewers 16 inches or greater in diameter.
 - j. Plans shall be reviewed by the Design Engineer for backwater valves. These are required where finished floor elevations are below both upstream and downstream manhole rim elevations.
 - k. Waste that is determined to be detrimental to the City's wastewater system or designated treatment facilities shall not be discharged into the wastewater collection system. In some cases a private pre-treatment system may be permitted. Contact the City Engineer to discuss options.
 - l. Grease, oil, or sand interceptors which are acceptable to the City and approved by the City Engineer shall be provided between the building and the connection to the City's sewer system for laundry, restaurant, automobile service, and other similar facilities when, in the opinion of the City Engineer, they are necessary for the proper handling of liquid wastes. Interceptors shall be supplied and maintained by the Owner. A permit administered by the Logan City pre-treatment program is required and must be renewed annually. Permitted industries are also subject to quarterly or monthly inspections, sampling and reporting as required by their permit.
 - m. No sewer Service Laterals will be allowed between a sewer trunk and an odor control manhole.
2. Service Lateral Size
- a. Service Laterals for private single family residential buildings shall be a minimum diameter of 4 inches and a maximum of 6 inches. In subdivisions, a 4-inch diameter tap shall be provided for each platted lot.
 - b. Commercial and industrial buildings shall have a 6-inch minimum private Service Lateral and shall provide service adequate for discharge.

- c. Private sewer Service Laterals are allowed to serve no more than 3 detached single family houses if the homes are constructed on a private lane. Homes constructed with frontage to the public right of way shall connect directly to the City's public sewer system.
 - d. Condominium and town home buildings that serve multiple units shall each have a 6-inch minimum private Service Lateral.
 - i Up to 12 condominium or town house residential units may be connected to a single 6-inch Service Lateral without detailed support engineering.
 - ii Detailed engineering shall demonstrate that the size of the Service Lateral is sufficient to carry the flow. In no case shall more than 12 condominium or town home units be connected to a single sewer Service Lateral.
 - e. Commercial lots without buildings shall have no Service Laterals unless requested by owners; then only 6-inch or larger Service Laterals shall be allowed.
 - f. Clean outs are not allowed on public or private Service Laterals larger than 6 inches. Manholes shall be provided at terminations, changes in direction, and at the appropriate spacing locations.
 - g. Property owners are responsible for maintenance of sewer laterals from the Sewer Main to the structure.
3. Service Lateral Location
- a. Water and sewer services shall be separated 10-feet horizontally from each other and located 5-feet from property lines on opposite corners of a lot. Service Laterals shall be located so as to avoid conflicts with driveway locations.
 - b. Proposed tap locations shall be shown on all plans.
 - c. Sewer Service Laterals shall be located a minimum of 2 feet below a water main or water service line. When it is not



possible to maintain sufficient clearance, or if the sewer service will pass over the water main, the sewer service must be constructed such that no joints are located within 10 feet on either side of the crossing.

4. Construction Details

- a. All construction shall be per this manual, State Code, and APWA Standard Details and Specifications.
- b. Sewer laterals shall be backfilled to the same standards as the Sewer Main line and other pipes.

M. Inspections

1. Televised Inspections

- a. All newly installed sewers shall be inspected by closed-circuit television (CCTV) methods acceptable to the City, prior to commissioning the line. Any defects discovered during televised inspection shall be corrected at no cost to the City. After correction of defects has been completed, affected sewer sections shall be re-televised at no cost to the City. A flash drive containing video of all televised inspections shall be provided to the City prior to final acceptance/commissioning of the sewer.
- b. Sewer Mains shall be cleaned and reinspected by CCTV no more than 14-days prior to the one-year warranty inspection.
- c. All Sewer Laterals shall be cleaned and inspected by CCTV no more than 14-days prior to inspection for occupancy of the structure or unit served. Occupancy will not be granted to any structure until the Sewer Lateral serving the structure or unit is inspected via CCTV and approved by the City.
- d. All televised inspections shall comply with the City's "Sewer Television Inspection Standards". Any defects discovered during televised inspection shall be corrected at no cost to the City. After correction of defects has been completed, affected sewer sections shall be re-televised at no cost to the City. A flash drive containing video of all televised inspections shall be provided to the City prior to final acceptance of the sewer line or lateral.



2. Sewer System Cleaning and Testing

- a. Sewer lines and services shall be commissioned per APWA specifications 33 08 00. Testing, commissioning, inspection, and repairs shall be at no cost to the City.
 - i. Sewer piping greater than 18-inches in diameter shall be tested for distortion. Testing and acceptance shall be in accordance with APWA and manufacturer's requirements. If determined by the City Engineer, distortion testing may be required on smaller piping.
 - ii. Sewer systems shall be maintained free of debris, contaminants, and other foreign discharges by the owner or developer through the one-year warranty period and longer if construction activities continue beyond the one-year warranty period.
 - iii. For the purpose of clearly identifying the level of water remaining in the line, the CCTV camera shall have a means to measure or gauge the depth of water.
 - iv. Sags shall be repaired and the entire line shall be videoed again to demonstrate that the repair is adequate.
 - v. Gravity Sewer systems shall pass an air test in accordance with APWA 33 08 00. There shall be no observable loss of pressure for the duration of a pressure test.
 - vi. Gravity Sewer systems shall pass an infiltration test in accordance with APWA 33 08 00. There shall be no water entering the system by means of infiltration. Any amount of infiltration shall be located and fixed prior to approval.
 - vii. The City's inspector shall be present during inspections and when testing is performed.

N. Force Mains

1. Velocity Requirements

- a. The design velocity of flow in the force main shall be between 4 fps and 6 fps.
 2. All types of pipe materials used in design of force mains shall be PVC or HDPE.
 3. Force mains shall be identified as such with marking tape labeled SEWER placed a minimum of 36" above the Force main or just below the pavement section (pit run for road) if less than 36" above the pipe.
 4. Forced mains shall be identified by 12 gauge, solid copper tracer wire run with pipe.
 - a. Provide a connection point every 500 linear feet where the tracing wire can be accessed and used for location purposes.
- O. Air Release Valves
1. Approved air release valves designed for sewage shall be provided on force mains at all peaks in elevation and at other locations determined by the City Engineer. See the City Standard Details for air release valve requirements and the Approved Materials List for approved models.
- P. Force Main Cleanouts and Manholes
1. Two-way cleanouts shall be provided every 800 feet or one-way cleanouts every 400 feet. See the City Standard Details.
 2. Refer to APWA detail 433 alternate 2 with the following modifications for details regarding force main discharge into a manhole construction:
 - a. Manholes receiving discharge from Force main shall be at least 60-inches in diameter.
 - b. The Tee & Wye shall be replaced with a cross that also includes a screw-in plug on the top.
 - c. The interior of manholes receiving discharge from forced sewer mains shall be entirely constructed of concrete with anchored HDPE liner (Perfect Lined Manhole by Geneva). Upon approval by the City Engineer, manholes may be



coated with a City approved corrosion resistant coating. See the City Approved Materials List for Wastewater.

Q. Water Line Separation

1. The minimum separation between force mains and water lines shall be 2 feet vertical and 10 feet horizontal, all as measured from nearest wall to nearest wall.

R. Force Main Testing

1. Prior to issuance of a Certificate to Operate, all force mains shall be pressure tested. Preparatory to testing, the section of the pipeline to be tested shall be filled with water and placed under a slight pressure for at least 48 hours. The pipeline shall then be brought up to working pressure plus 50 psi, or to 125% of working-class pressure, whichever is greater. This pressure shall be maintained on the section under test for a period of not less than 4 hours.

5.1.11 Wastewater Treatment

A. Treatment Plants

1. The subject of wastewater treatment plant design is beyond the scope of this design manual. Currently all wastewater collected by the City is treated at the Logan treatment plant.

B. Onsite Treatment (Septic Systems)

1. When sewer service is not available as defined by the City code, a temporary septic system may be allowed with the approval of both the City and the Bear River Department of Health Services.
2. Septic systems are not allowed in source protection zones without special approval as defined in City code.
3. When septic systems are approved, a “dry” sewer line shall be installed along the entire length of the property line frontage for future connection. The property line frontage is that portion of the property along a public right-of-way. If a parcel to be developed has more than one property line frontage, the City will require a



sewer line to be installed along all frontages that are planned to have a sewer line.

4. The operation and maintenance of septic systems are the responsibility of the Owner. The City will not accept any septic system for operation and maintenance.

C. **Reclaimed Water**

The City's reclaimed water is currently managed by Logan City and is not available for other uses.

5.2 **Nibley City Sewage Lift Station Standards**

5.2.1 **Purpose**

The purpose of this standard is to provide direction for the construction of small public and private lift stations that propose to discharge into the Nibley City Wastewater Collection System

5.2.2 **Site Selection**

- A. In selecting a site for a sewage pumping facility, consideration should be given to:
 1. Accessibility
 2. Drainage Characteristics
 3. Visual Impact
 4. Function and Design Constraints
- B. The potential for flooding should be considered when selecting a pump station location. The station's equipment shall be protected from damage and remain operable, and accessible to large equipment during a 100-year flood event.

5.2.3 **Lift Station Design**

- A. Sewage lift station requirements are provided by UAC Section R317-3-3. The current version as of 3/10/2022 is included below. Additional requirements specific to the City can be obtained from the City

Engineer before beginning design. At a minimum, telemetry, dual pumps, generator, three-phase power, and odor control will be required.

- B. It is recommended that, prior to the preparation of construction drawings, a Preliminary or Basis of Design Report be prepared and submitted to the City for acceptance. The Preliminary Report should clearly identify why a lift station is needed; provide a map illustrating the sub basin contributing to the lift station with invert and rims of the sewer lines and manholes in the subbasin; outline the type of equipment and controls proposed for the station.
- C. A Final Design Report, prepared by a Registered Professional Engineer licensed in the State of Utah, must accompany all lift station design drawings. The final report shall update the preliminary report with any changes or provide additional details not included in the preliminary report.

5.2.4 Sewer Lift Station Design Standards

- A. The lift station site shall be laid out as follows:
 - 1. A minimum 16-foot wide entry gate
 - 2. A minimum 16-foot wide all weather drive into the site from the gate to allow maintenance equipment to access the site up to the wet well location and for staff to work around that equipment.
 - a. The 16-foot shall be a clear width between the near edge of the wall and the closest above ground lift station appurtenance.
 - 3. A minimum 8 foot clear width shall be provided around the remaining lift station site between the near edge of the fence and above ground lift station appurtenance.
- B. There shall be a minimum of two pumps at each site. Pumps shall be capable of passing 2-1/2-inch solids, and shall be equipped with stainless steel motor shafts.
- C. Check valves shall be silent closing type and located in a separate vault.
- D. Ball Check isolation valves shall be constructed after check valves.
- E. Three-phase 480-Volt power shall be provided.
- F. Field prints shall include all electrical information.

- G. Phase protection shall be provided for all three-phase motors and pumps.
- H. An hour meter shall be provided for each pump.
- I. Pump failure indicator lights shall be provided on the control panel and the exterior of the station.
- J. An access hatch and permanent ladder shall be installed in the wet well. The ladder shall be Type 304 stainless steel or greater.
- K. All lift station control panels shall be designed to include systems that communicate with the City's SCADA system via radio telemetry.
- L. Only submersible pumps shall be used.
 - 1. Pumps shall be connected to stainless steel guide rails and retrieval chains with quick release points at the pump.
- M. Approved submersible pump stations shall be supplied per manufacture and model identified in the Wastewater Approved Materials List found on the City's website. All pumps shall be connected to the City's SCADA system.
- N. A minimum of three sets of the operation and maintenance manuals shall be prepared and provided to the Public Works Department prior to the final inspection.
- O. Force main shall be identified as such with marking tape and tracer wire one foot above the pipe.
- P. Force main cleanouts shall be installed per Engineering Design Standards.
- Q. If the Lift Station is located within 100 feet of a residential home, a block wall shall be constructed around the perimeter of the lift station site to provide noise and visual abatement.
- R. Odor control measures must be identified in the Design Concept Report and incorporated into the design.
- S. Ventilation of the wet well to be connected to the dry well with a fan mounted in the dry well vault for access and maintenance.
- T. The lift station wet well shall be constructed of polymer concrete.

- U. Spare parts shall be provided as recommended by the manufacturers.
- V. Electrical specifications information is to be provided on field prints as follows:
- W. An emergency generator shall be provided and shall include the following:
 - 1. Double walled skid fuel tank large enough to hold fuel sufficient to run the generator for 48 hours under a full electrical load.
 - 2. The generator shall run on diesel fuel
 - 3. A weatherproof sound attenuating cover shall be provided for the generator.
 - 4. Connected to the City's SCADA system.
- X. Sight lighting shall be provided in a manner to light the entire lift station site but shall not spill out onto neighboring residential properties.
- Y. A telemetry radio and antenna shall be provided at a height that allows for connection to a City receiving radio. A radio study may be required to determine the height of the radio.
- Z. A MAG meter that is set up for and connected to the City's SCADA system shall be installed in the dry well

5.2.5 Electrical specifications

- A. Size and type of conduits
 - 1. Size and type of over-current protection for all disconnects
 - 2. Phase protection for all three-phase motors and pumps
 - 3. Floats shall be used for all controls and alarms.
 - 4. Failure indicator lights on control panel
 - 5. Hour meter totalizer for each pump
 - 6. Flashing light to warn of pump failure
 - 7. Alarm circuitry to one terminal board for telemetry



8. No electrical connections in wet well
9. All lift station equipment shall conform to the City's current SCADA standards.

NOTE: It is recommended that designers coordinate their pump station design with the City Engineer prior to final plan preparation.

5.2.6 UAC R317-3-3 - Sewage Pumping Stations

- a. General. Sewage pumping station structures, and electrical and mechanical equipment shall be protected from physical damage that would be caused by a 100-year flood. Sewage pumping stations must remain fully operational and accessible during a 25-year flood.
- b. Design
 - A. Pumping Rates. The pumps and controls of main pumping stations, and especially pumping stations pumping to the treatment works or operated as part of the treatment works, should be selected to operate at varying delivery rates to permit discharging sewage at approximately its rate of delivery to the pump station.
 - B. System - Head Calculation
 1. The design engineer shall submit system-head calculations and curves. System-head curves for C values of 100, 120 and 140 in the Hazen William's equation for calculating head loss corresponding to minimum, median and maximum water levels shall be developed.
 2. A system-head curve for C value of 120 corresponding to median (normal operating) water level shall be used to make preliminary selection of motor and pump. The pump and motor must operate satisfactorily over the entire range of system-head curves for C values of 100 and 140 corresponding to minimum and maximum water levels intersected by the head-discharge relationship of a given pump.
 3. Pumps and motors shall be sized for the 10-year peak flows; preferably the 20-year sewage flow requirements. These operating points shall be shown on the system-head curves.

-
- C. Accessibility. The pumping station shall be readily accessible by maintenance vehicles during all weather conditions. The facility should be located off the traffic way of streets and alleys.
 - D. Grit. Where it is necessary to pump sewage before grit removal, the design of the wet well and pump station piping shall be such that operational problems from the accumulation of grit are avoided.
 - E. Odor and Corrosion Control. The pumping station design should incorporate measures for:
 - 1. mitigating the effects of sulfide corrosion to structure and equipment; and
 - 2. effective odor control when a populated area is within close proximity.
 - F. Structures
 - 1. Dry wells, including their superstructure, shall be completely separated from the wet well.
 - 2. Provision shall be made to facilitate maintenance and removal of pumps, motors, and other mechanical and electrical equipment.
 - 3. Safe means of access and proper ventilation shall be provided to dry wells and to wet wells containing either bar screens or mechanical equipment requiring inspection or maintenance.
 - a. For built-in-place pump stations, a stairway with rest landings shall be provided at vertical intervals not to exceed 12 feet (3.7 meters). For factory-built pump stations over 15 feet (4.6 meters) deep, a rigidly fixed landing shall be provided at vertical intervals not to exceed 10 feet (3.0 meters). Where a landing is used, a suitable and rigidly fixed barrier shall be provided to prevent an individual from falling past the intermediate landing to a lower level.
 - b. Where space requirements are insufficient, the design may provide for a manlift or elevator in lieu of landings in a factory-built station if the design includes an emergency access or exit.

- c. Local, state and federal safety requirements, including those in applicable fire code, the Uniform Building Code, etc., must be reviewed and complied with. Those requirements, if more stringent than the ones stated above, shall be incorporated in the design.
4. Construction Materials. The materials selected in construction and installation must be safe and able to withstand adverse operating environmental conditions caused by presence of hydrogen sulfide and other corrosive gases, greases, oils, and other constituents frequently present in sewage.
- c. Pumps and Pneumatic Ejectors
 - A. Multiple Units
 - 1. At least two pumps or pneumatic ejectors shall be provided. A minimum of three pumps shall be provided for stations handling flows greater than 1 million gallons per day (3,785 cubic meters per day).
 - 2. If only two units are provided, they should have the same capacity. Each shall be capable of handling flows in excess of the expected maximum flow. Where three or more units are provided, they should be designed to fit actual flow conditions and must be of such capacity that with any one of the largest units out of service, the remaining units shall have capacity to handle maximum sewage flows.
 - B. Protection Against Clogging
 - 1. Pumps handling sewage from 30 inch (76 centimeters) or larger diameter sewers shall be protected by readily accessible bar racks from clogging or damage.
 - 2. Bar racks should have clear openings not exceeding 1-1/2 inches (6.4 centimeters). The design shall provide for a mechanical hoist.
 - 3. The design engineer shall consider installation of mechanically cleaned and duplicate bar racks in the pumping stations handling larger than five million gallons per day (18,900 cubic meters per day) rate of flow.



4. Small pumping stations pumping less than one million gallons per day (3,785 cubic meters per day) shall be equipped with bar racks or inline grinding devices, etc., to prevent clogging.
- C. Pump Openings. Except where grinder pumps are used, pumps shall be capable of passing spheres of at least 3 inches (7.6 centimeters) in diameter, and pump suction and discharge piping shall be at least 4 inches (10.2 centimeters) in diameter.
 - D. Priming. The pump shall be so placed that it will operate under a positive suction head under normal operating conditions, except for submersible pumping stations.
 - E. Electrical Equipment. Electrical systems and components (e.g., motors, lights, cables, conduits, switchboxes, and control circuits) in raw sewage wet wells, or in enclosed or partially enclosed spaces where hazardous concentrations of flammable gases or vapors may be present, shall comply with the National Electrical Code requirements for Class 1 Group D, Division 1 locations. In addition, equipment located in the wet well shall be suitable for use under corrosive conditions. Each flexible cable shall be provided with watertight seal and separate strain relief. A fused disconnect switch located above ground shall be provided for all pumping stations. When such equipment is exposed to weather, it shall as a minimum, meet the requirements of weatherproof equipment (NEMA 3R).
 - F. Intake. Each pump should have an individual intake. Turbulence should be avoided near the intake in wet wells. Intake piping should be as straight and short as possible.
 - G. Dry Well Dewatering. A separate sump pump equipped with dual check valves shall be provided in dry wells to remove leakage or drainage. Discharge shall be located as high as possible. A connection to the pump suction is also recommended as an auxiliary feature. Water ejectors connected to a potable water supply will not be approved. All floor and walkway surfaces should have an adequate slope to a point of drainage. Pump seal water shall be piped to the sump.
 - H. Controls
 1. Type. Control systems for liquid level monitoring shall be of the air bubbler type, the capacitance type, the encapsulated float type, or the non-contact type. The selection of type of controls must be based on wastewater characteristics and other site related conditions. The Director may approve the existing float-tube control

systems on pumping stations being upgraded. The electrical equipment shall comply with the National Electrical Code requirements for Class I, Group D, Division 1 locations.

2. Location. The level control system shall be located away from the turbulence of incoming flow and pump suction.
3. Alternation. The design engineer must consider automatic alternation of the sequencing of pumps in use.

I. Valves

1. Suction Line. An isolation valve shall be placed on the suction line of each pump except on submersible pumps.
2. Discharge Line
 - a. Isolation and check valves shall be placed on the discharge line of each pump. The check valve shall be located between the isolation valve and the pump.
 - b. Check valves shall not be placed in the vertical run of discharge piping unless the valve is designed for that specific application.
 - c. Ball valves may be permitted in the vertical runs.
 - d. All valves shall be suitable for the material being handled, and capable of withstanding normal operating pressure and water hammer.
 - e. Where limited pump backspin will not damage the pump and low discharge head conditions exist, a short individual force main for each pump, may be approved by the Director in lieu of a discharge manifold.
3. Location. Valves shall not be located in wet well. They shall be located in a dry well adjacent to the pumps or in an adjacent isolated pit appropriately protected from physical, weather or freezing damage, with proper access for operation and maintenance.

J. Wet Wells

1. Divided Wells. Wet well should be divided into multiple sections, properly interconnected, to facilitate repairs and cleaning, and non-turbulent hydraulic operating condition to each pump inlet.

2. Size. The wet well size and level control settings shall be appropriate to avoid heat buildup in the pump motor due to frequent starting (short cycling), and septic conditions due to excessive detention time.
 3. Floor Slope. The wet well floor shall have a minimum slope of one to one to the hopper bottom. The horizontal area of the hopper bottom shall be not greater than necessary for proper installation and function of the pump inlet.
- K. Ventilation. All pump stations must be ventilated to maintain safe operating environment. Where the pump pit is below the ground surface, mechanical ventilation is required, so arranged as to independently ventilate the dry well and the wet well if screens or mechanical equipment requiring maintenance or inspection are located in the wet well. There shall be no interconnection between the wet well and dry well ventilation systems. In pits over 15 feet (4.6 meters) deep, multiple inlets and outlets are recommended. Dampers should not be used on exhaust or fresh air ducts. Fine screens or other obstructions in air ducts should be avoided to prevent clogging. Switches for operation of ventilation equipment should be marked and located for convenient operation from outside of the enclosed environment. All intermittently operated ventilating equipment shall be interconnected with the respective pit lighting system. Automatic controls are recommended for intermittently ventilated pump stations. Fan parts should be of non-corrosive material. All parts adjacent to moving ones should be of non-sparking materials. Consideration should be given to installation of automatic heating and dehumidification equipment.
1. Wet Wells. Ventilation may be either continuous or intermittent. Ventilation, if continuous, shall provide at least 12 complete air changes per hour; if intermittent, at least 30 complete air changes per hour. Ventilating equipment should force air into wet well rather than exhaust it from wet well.
 2. Dry Wells. Ventilation may be either continuous or intermittent. Ventilation, if continuous, shall provide at least 6 complete air changes per hour; if intermittent, at least 30 complete air changes per hour.
- L. Flow Measurement. Continuous measuring and recording of sewage flow shall be provided at all pumping stations with a design pumping capacity greater than one million gallons per day (3,785 cubic meters per day).

- M. Water Supply. There shall be no physical connection between any potable water supply and a sewage pumping station which under any condition might cause contamination of the potable water supply. The potable water supply to a pumping station shall be protected against cross connection or backflow.
- 3.4. Self-Priming Pumps. Self-priming pumps shall be capable of rapid priming and repriming at the lead pump on elevation. Such self-priming and repriming shall be accomplished automatically under design operating conditions. Suction piping should not exceed the size of the pump suction and shall not exceed 25 feet (7.6 meters) in total length. Priming lift at the lead pump on elevation shall include a safety factor of at least 4 feet (1.2 meters) from the maximum allowable priming lift for the specific equipment at design operating conditions. The combined total of dynamic suction lift at the pump off elevation and required net positive suction head at design operating conditions shall not exceed 22 feet (6.7 meters).
- 3.5. Submersible Pump Stations. Submersible pump stations may be used for flows less than 0.25 million gallons per day (946 cubic meters per day). The Director may approve submersible pump stations for flows greater than 0.25 million gallons per day (946 cubic meters per day), based on operational, reliability and maintenance considerations. The submersible pumps stations shall meet the design requirements stated above, except as modified in this section.
- A. Construction. Submersible pumps and motors shall be designed specifically for raw sewage use, including totally submerged operation during a portion of each pumping cycle. An effective method to detect shaft seal failure or potential seal failure shall be provided, and the motor shall be of squirrel-cage type design without brushes or other arc-producing mechanisms.
- B. Pump Removal. Submersible pumps shall be readily removable and replaceable without dewatering the wet well or disconnecting any piping in the wet well.
- C. Electrical
1. Power Supply and Control. Electrical supply, control and alarm circuits shall be designed to allow for disconnection of the equipment from outside and inside of pumping station. Terminals and connectors shall be protected from corrosion by location outside

of wet well or through use of watertight seals. If located outside of the pumping station, weatherproof equipment shall be used.

2. Controls. The motor control center shall be located outside of the wet well and be protected by a conduit seal or other appropriate measures meeting the requirements of the National Electrical Code, to prevent the atmosphere of the wet well from gaining access to the control center. The seal shall be so located that the motor may be removed and electrically disconnected without disturbing the seal.
 3. Power Cord. Pump motor power cords shall be designed for flexibility and serviceability under severe service conditions and shall meet the requirements of the Mine Safety and Health Administration for trailing cables. Ground fault interruption protection shall be used to deenergize the circuit in the event of any failure in the electrical integrity of the cable. Power cord terminal fittings shall be corrosion-resistant and constructed in a manner to prevent the entry of moisture into the cable, shall be provided with strain relief appurtenances, and shall be designed to facilitate field connecting.
- 3.6. Valves. Valves shall be located in a separate valve pit. Accumulated water shall be drained to the wet well or the soil. If the valve pit is drained to the wet well, an effective method shall be provided to prevent sewage gases and liquid from entering the pit during surcharged wet well conditions.
- 3.7. Alarm Systems.
- A. Alarm systems shall be provided for pumping stations. The alarm shall be activated in cases of power failure, high water level in dry or wet well, pump failure, use of the lag pump, air compressor failure, or any other pump malfunction.
 - B. Pumping station alarms shall be telemetered, including identification of the alarm condition, to the operating agency's facility that is manned 24 hours a day. If such a facility is not available and 24-hour holding capacity is not provided, the alarm shall be telemetered to the operating agency's facility during normal working hours and to the home of the person(s) responsible for the lift station during off-duty hours.
 - C. The Director may approve audio-visual alarm systems with a self-contained power supply in lieu of the telemetering system outlined above, depending upon location, station holding capacity and inspection frequency.

3.8. Emergency Operation

- A. Pumping stations and collection systems shall be designed to prevent bypassing of raw sewage and backup into the sewer system. For use during possible periods of extensive power outages, mandatory power reductions, or uncontrolled storm events, a controlled high-level wet well overflow or emergency power generator shall be provided. Where a high level overflow is utilized, storage or retention tanks, or basins, shall be provided having at least a 2-hour retention capacity at the anticipated overflow rate.
- B. The applicant must review the requirements of R317-6 (Ground Water Quality Protection Rule) for compliance with the said rule for earthen retention basins.
- C. The operating agency shall provide:
 - 1. an in-place or portable pump, driven by an internal combustion engine or an emergency generator capable of pumping from the wet well to the discharge side of the station for pump stations with a capacity in excess of one million gallons per day (3,785 cubic meters per day), and
 - 2. an engine-driven generating equipment or an independent source of electrical power or emergency generators capable of pumping from the wet well to the discharge side of the station for pump stations with a capacity in excess of five million gallons per day (18,925 cubic meters per day).

3.9. Auxiliary and Emergency Equipment Requirements

- A. General. The following general requirements shall apply to all internal combustion engines used to drive auxiliary pumps, service pumps through special drives, or electrical generating equipment.
 - 1. Engine Protection. The engine must be protected from damaging operating conditions. Protective equipment shall shut down the engine and activating an alarm on site unless continuous manual supervision is planned. Protective equipment shall monitor for conditions of low oil pressure and overheating, Oil pressure monitoring is not required for engines with splash lubrication.
 - 2. Size. The engine shall have adequate rated power to start and continuously operate all connected loads.

3. Fuel Type. The type of fuel must be carefully selected for maintaining reliability and ease of starting, especially during cold weather conditions. Unused fuel from the fuel storage tank should be removed annually, and the tank refilled with fresh fuel.
 4. Engine Ventilation. The engine shall be located above grade with adequate ventilation of fuel vapors and exhaust gases.
 5. Routine Start-up. All emergency equipment shall be provided with instructions indicating the need for regular starting and running of such units at full loads.
 6. Protection of Equipment. Emergency equipment shall be protected from damage at the restoration of regular electrical power.
- B. Engine-Driven Pumping Equipment. Where permanently installed or portable engine-driven pumps are used, the following requirements in addition to general requirements apply:
1. Pumping Capacity. Engine-driven pump(s) shall be capable of pumping at the design pumping rates unless storage capacity is available for flows in excess of pump capacity. Pumps shall be designed for anticipated operating conditions, including suction lift if applicable.
 2. Operation. Provisions shall be made for automatic and manual start-up and load transfer. The pump must be protected against damage from adverse operating conditions. Provisions should be considered to allow the engine to start and stabilize at operating speed before assuming the load. Where manual start-up and transfer is justified, storage capacity and alarm system must meet the requirements stated hereinabove.
 3. Portable Generating Equipment. Where portable generating equipment or manual transfer of power to the pumping equipment is provided, sufficient storage capacity shall be provided in the design of pumping station, to allow time for detection of pump station failure and transportation and connection of generating equipment. The use of special electrical connections and double throw switches are recommended for connecting portable generating equipment.

3.10. Instructions and Equipment

- A. Sewage pumping stations and their operators must be supplied with a complete set of operational instructions, including emergency procedures, maintenance schedules, special tools, and necessary spare parts.
- B. Local, state and federal safety requirements, including those in applicable fire code, the Uniform Building Code etc., must be reviewed and complied with. Those requirements take precedence over the foregoing requirements, if more stringent, and should be incorporated in the design.

3.11. Force Mains

- A. Velocity. A velocity of not less than 2 feet per second (0.61 meter per second) shall be maintained at the average design flow, to avoid septic sewage and resulting odors.
- B. Air Relief Valve. An automatic air relief valve shall be placed at high points in the force main to prevent air locking.
- C. Termination. Force mains should enter the gravity sewer system at a point not more than 2 feet (30 centimeters) above the flow line of the receiving manhole.
- D. Design Pressure. The force main and fittings, including reaction blocking, shall be designed to withstand normal pressure and pressure surges (water hammer).
- E. Special Construction. Force main construction near streams or used for aerial crossings shall meet the requirements stated in Sewers.
- F. Design Friction Losses
 - 1. Friction losses through force mains shall be based on the Hazen and Williams formula or other hydraulic analysis to determine friction losses. When the Hazen and Williams formula is used, the design shall be based on the value of C equal to 120; for unlined iron or steel pipe the value of C equal to 100 shall be used.
 - 2. When initially installed, force mains will have a significantly higher C factor. The higher C factor should be considered only in calculating maximum power requirements.
- G. Separation from Water Main. The applicant or the design engineer must review the requirements stated in R309-112.2 - Distribution System



rules, Drinking Water and Sanitation Rules, to assure compliance with the said rule.

- H. Identification. A clearly labelled tracer location tape shall be placed two feet above the top of force mains less than or equal to 24 inch (61 centimeters) in diameter, along its entire length.

Section 6. Storm Water Systems

Cache Valley Storm Water Design Standards As Amended by Nibley City April 2019

These design standards provide the required storm water design criteria and methodology to be utilized for all public and private development and redevelopment required by the Utah Pollutant Discharge Elimination System (UPDES) General Permit for Discharges from Small Municipal Separate Storm Sewer Systems (MS4 or MS4 Permit). Any deviations from these criteria shall be reviewed and approved, only if adequate, by the City Engineer in writing prior to initiating and again before finalizing the design or bidding the project. Where any deviations may also affect a canal company or irrigation ditch, a written approval of the canal company shall also be required before the designs will be approved and before bidding the project.

All designs must utilize and comply with the most current edition of the Nibley City Design and Construction Standards and Specifications.

A. DESIGN REQUIREMENTS

All projects, irrespective of the size or type, shall meet these requirements. Where projects are governed by a state or federal agency, their standards shall take precedence. All designs shall be in compliance with the PWD's constructions standards and specifications.

Subsequent sections identify the required methodology based upon the size and type of the project.

1. Storm Water Submittals

B. Submittals Required

Every submittal shall include the calculations in Table B-1 based on contributing storm water runoff source area.

Table B-1: Storm Water Submittals Required

Contributing Areas	Requirements
--------------------	--------------

Less than 1.0 Acre disturbed and not part of a common plan of development	Pollution Control Plan (See B.2) Hydrologic checklists and summary calculations required on checklist. LID and BMP Selection Checklist
Greater than 1.0 acres disturbed or part of a common plan of development.	SWPPP Hydrologic report and copy of checklists, with associated calculations for each drainage basin Water Quality/Treatment Requirements Checklist LID and BMP Selection Documentation and Checklist

1. Storm Water Pollution Prevention Plan

Storm water pollution prevention plans (SWPPP) are required on all projects in PWD boundaries and every project must comply with PWD standards and specifications, whether approved by the PWD or not. Table B-2 summarizes the requirements of the SWPPP.

Table B-2, SWPPP Requirements

Contributing Area Size	Minimum Requirements
Less than 1.0 Acre and NOT part of a common plan of development	<p>A pollution control plan that will address at a minimum the control and prevention of the following: erosion and sediment; dust; debris and garbage; concrete washout and excess material, wastewater from washout and cleanout of stucco, paint, form release oils, curing compounds or other construction materials; soaps solvents or detergents used in vehicle or equipment washing; and toxic or hazardous substances from spills or other releases. Each pollution control plan shall also include an inspection and maintenance plan, record keeping and training, and final stabilization. These can be on a standard design sheet as detailed notes with supporting details or a standalone document.</p>

<p>1.0 Acre and larger OR Less than 1.0 Acre and part of a common plan of development</p>	<p>A full SWPPP using the UDEQ template downloadable from the DWQ at the following web site: http://www.deq.utah.gov/Permits/water/updes/stormwatercon.htm All elements in the SWPPP document must be included in the submittal.</p>
---	--

2. Irrigation Canals and Systems

Every existing irrigation ditch or canal has played a part of the City storm water facilities from the settling of the community. When the canals were built, they delivered water from the river and intercepted storm water runoff from uphill naturally. However, when the canals flooded, there weren't houses at risk back then. Now, with ongoing development, these conditions have changed. Design of storm drainage systems using the canals have special requirements as a result and must be approved by not only the City, but also the canal company serving the area of question.

The PWD requires that irrigation ditches and canals that deliver irrigation water be preserved to deliver the water to the water users and to allow access to the ditch or canal for maintenance.

All irrigation canals, pipes, ditches, channels, structures, diversions, and other portions of the system shall be designed for the full range of base flows including historical maximum flows, historical minimum flows, and the full water right flow. Then the channel shall have the upstream storm drain inflows and irrigation return flows added to the model to ensure that all future systems have sufficient capacity. These design flows must to be approved by the associated canal company or irrigation ditch owners in writing and the City Engineer.

C. Water Right Flows

The design flow will be the maximum flow allowed by the canal water rights. Flows down laterals and distribution ditches shall be obtained in accordance with the agreements between the Cities and the canal companies Obtain the water righted flows and the lateral flows directly from the canal companies. These must be documented in a letter signed by an authorized canal company representative to be accepted by the City. Primary canal company contacts are available from the City.

a) Return Flows

Many of the canals receive return flows from the upstream canals. This can seriously complicate the storm water design since many people turn off their

irrigation water and simply pass it down the ditch during storms. This can result in major flooding issues on some canals, even without any storm water entering the canals. When designing a section of the canal, it shall be necessary to take the return flows into consideration and to discuss them with the canal companies. Again, the agreed upon flows must be obtained in accordance with the canal agreements with the Cities.

2. Storm Event (Frequency and Duration Requirements)

Design all storm water facilities associated with projects shall be designed in accordance with Table B-3.

Table B-3: Storm Event Frequency and Duration Design Requirements

Contributing Area Size	Temporary Construction BMPs Design Frequency	Permanent Construction BMPs Design Frequency	Design Storm Duration	Rainfall Depths at KVNU Radio Station
Less than 1.0 acres	2-Year	100-year	Retention/Infiltration: 48 hours All Other BMPS: 24 Hours	24 Hour, 2-year: 1.46 inches 10-year: 2.04 inches 25-year: 2.41 inches
1.0 acres and less than 640 acres	2-Year	100-year	Retention/Infiltration: 48 hours All Other BMPS: 24 Hours	50-year: 2.71 inches 100-year: 3.02 inches 48-hour,
640 Acres and larger	2-year	10-year, 25-year, 50-year, and 100-year	Retention/Infiltration: 48 hours All Other BMPS: 24 Hours	2-year: 1.68 inches 10-year: 2.33 inches 25-year: 2.75 inches 50-year: 3.08 inches 100 Year: 3.42 inches

Existing development shall be required to construct storm water facilities to meet the new storm water design criteria at the time of redevelopment or reconstruction of any facilities. However, the return frequency and design duration may be modified under extreme conditions at the direction of the City Engineer with approval of the agency managing the receiving waters in writing.

3. Allowable Storm Water Discharge

There are two criteria related to the allowable discharge that shall be met by all projects. Any exceptions to this requirement shall be evaluated and approved on a case by case basis using the methodology provided in this document and other equivalent water quality treatments shall be utilized. Approval by the PWD is required before any deviations are allowed.

a) Mandatory Onsite Management

Under the MS4 Permit, all new development and re-development, including roads, shall be designed to manage the 90th percentile rainfall event as defined Table B-4 and Table

B-5 of these design standards. The MS4 permit requires that the entire volume of the 90th percentile storm that falls on the site shall be infiltrated, evaporated, and/or harvested (not exceeding amounts allowed by Utah Division of Water Rights).

Table B-4: 90th Percentile Storm Definitions in Cache County

Gauging Station	LOGAN RADIO KVNU UT US	LOGAN UT STATE UNIVERSITY UT US	LOGAN 5 SW EXPERIMENTAL FARM UT US
Depth (Inches)	.60	.66	.63
Elevation (ft)	4,505	4,778	4,491

Table B-5: 90th Percentile Design Criteria by PWD.

PWD	90 th Percentile Criteria
Logan City	Elevation < 4,642: Use 0.60 inches (KVNU) Elevation > 4,642: Use 0.66 inches (UT State University)

Under conditions where the 90th percentile storm cannot be managed on site, the designer shall provide a storm water design report that shall document the following:

1. Why the 90th percent storm cannot be managed on site.
2. Provide an alternative design rational that maximizes all of the following:
 - a. Infiltration,
 - b. Rain harvesting as allowed by the Utah Division of Water Rights,
 - c. Evapotranspiration.

b) Maximum Allowable Discharge

Most of the storm water in Cache Valley discharges to irrigation ditches and canals before reaching the rivers and streams. However, the ditches and canals are not designed to carry the increase in flows and are at risk of flooding both private and public property. Through negotiations with the canal companies, the following flow rate restrictions have been agreed upon:

- 1) The storm water runoff leaving the site during the 1 percent (100-year) event shall not exceed the lesser of:
 - a) Discharge prior to development (Historical Runoff Flow), or
 - b) 0.2 cfs per acre.
- 2) All storm water calculations shall include the following:
 - a) A calculation of Historical/Predevelopment flow rate. This is defined as the flow rate off of an irrigated pasture in good condition using the NRCS Curve Number Methodology defined in Section 3 of this standard.
 - i) If the Historical /Predevelopment flow rate is greater than 0.2 cfs/acre, then the maximum allowable discharge is 0.2 cfs/acre.
 - ii) If the Historical/Predevelopment flow rate is less than 0.2 cfs/acre, then the Historical/Predevelopment flow rate is the maximum allowable discharge.
 - b) A calculation of the Post-Construction flow rate and volume. If the Post- Construction flow rate, after the removal of the 90th percentile storm in B.4.a above, exceeds the maximum allowable discharge, additional detention or retention of flows shall be included in the design until the discharge is reduced to not more than the maximum allowable discharge.
- 3) The locations of the storm water discharge shall not be altered without permission. This is interpreted to mean that the ditches or canals receiving the discharge cannot be changed without express approval of the managers of the receiving ditches or canals.

6. Water Quality/Treatment Requirements and Possible BMPs

Under the MS4s Permit, Nibley City is required to “ensure that any storm water controls or management practices for new development and redevelopment will prevent or minimize impacts to water quality. BMPs must be selected that address pollutants known to be discharged or anticipated to be discharged from site.” The BMPs and Procedures included in this section summarize the design requirements for the most common BMPs to meet the MS4 permit requirements. Table B-6 summarizes many of the pollutants of concern based on expected land use.

Retail Gasoline Outlets	Oils, Fuel, Fuel Combustion byproducts, salt, sediment, garbage and trash.	Petroleum Products, Trash, BOD, E.coli, pesticides, herbicides, and other chemicals.	<p>Limit:</p> <ul style="list-style-type: none"> <input type="checkbox"/> total phosphorus < 0.07 mg/L. <input type="checkbox"/> total nitrogen < 6 mg/L <input type="checkbox"/> BOD5 < 5 mg/L. <input type="checkbox"/> E.Coli < 126 <input type="checkbox"/> TDS < 1200 mg/L <input type="checkbox"/> TSS cause <10 NTU <input type="checkbox"/> increase in receiving water <input type="checkbox"/> TSS < 70 mg/L <input type="checkbox"/> Petroleum cause no sheen <input type="checkbox"/> Trash cleaned up
Large Grassed Areas (parks, churches, etc.) and Golf Courses	Organic trash such as leaves, grass trimmings, decomposing vegetation, and animal waste. Application of fertilizers, pesticides, and herbicides	Phosphorus, Nitrogen, BOD, E.coli, pesticides, herbicides, and other chemicals.	<p>Limit:</p> <ul style="list-style-type: none"> <input type="checkbox"/> total phosphorus < 0.07 mg/L. <input type="checkbox"/> total nitrogen < 6 mg/L <input type="checkbox"/> BOD5 < 5 mg/L. <input type="checkbox"/> E.Coli < 126
Animal Operations (Feed Lots, Veterinary Clinics, Research Facilities)	Animal wastes	Phosphorus, Nitrogen, BOD, E.coli, pesticides, herbicides, and other chemicals.	<p>Limit:</p> <ul style="list-style-type: none"> <input type="checkbox"/> total phosphorus < 0.07 mg/L. <input type="checkbox"/> total nitrogen < 6 mg/L <input type="checkbox"/> BOD5 < 5 mg/L. <input type="checkbox"/> E.Coli < 126 <input type="checkbox"/> TSS cause <10 NTU <input type="checkbox"/> increase in receiving water <input type="checkbox"/> TSS < 70 mg/L

Table B6- Pollutants of primary concern

7. Required LID and BMP Selection

Under the MS4s Permit, Nibley City is required to “ensure that all storm water controls or management practices for new development and redevelopment will prevent or minimize impacts to water quality. BMPs must be selected that address pollutants known to be discharged or anticipated to be discharged from site.” As part of the selection of BMPs, the designer is required by the MS4 Permit to

evaluate and utilize LID methods that infiltrate, evapotranspire, or harvest and use storm water on site to protect water quality.

The BMPs and Procedures included in this section summarize the design requirements for the most common BMPs. However, the State of Utah DEQ has published a *Guide To Low Impact Development in Utah*, that may also be used and will be referred to by Nibley City staff while evaluating proposed LID practices and proje.

a) Mandatory LID Evaluation

Each project shall be evaluated for the use of LID approach with encourages the implementation of BMPs that infiltrate, evapotranspire or harvest and use storm water on site to protect water quality. The evaluation shall use shall include both structural and non-structural BMPs. If the designer determines that an LID approach cannot be utilized, the designer shall document and explain the reasons that LID will not work on the specific site and provide the rationale for the chosen alternative controls that will be used to obtain the same water quality objectives. This evaluation shall be completed on a case by case basis. As a minimum, the evaluation shall document:

1. Why LID won't work.
2. Rational for the chosen alternative controls on a case by case basis for each project.

LID to be considered on all Projects

(i) Development in riparian areas

1. Riparian areas are defined as being within 75 feet of centerline of stream drainage a basin larger than 1 square mile, and land within 25 feet of stream centerline for streams that drain areas of one square mile or less.
2. All structures shall maintain a setback of 25 feet from the top of the stream bank within a riparian area.
3. No more than 50% of the land area within the riparian area may be disturbed, including grading, clearing, grubbing, tree removal etc. All disturbed areas shall be revegetated within 60 days of initial disturbance.
4. Trees larger than 12" dbh shall not be removed from the riparian area unless they are considered a hazard tree, diseased or dead.

(ii) Open Space Preservation

1. Open space is an area of land or water that may be used for passive

or active recreation, agriculture, conservation, landscaped areas, preservation of the natural environment, scenic land, and/or other similar uses.

2. Minimum open space by development type shall include:
 - a. Residential: 20%
 - b. Commercial: 10%
 - c. Industrial: 10%
3. A permanent restrictive covenant in the form of a perpetual conservation easement shall be placed upon open space land requiring its maintenance as open space.

(iii) Land Designation as a Resource Conservation Zone

1. The Resource Conservation Zone includes lands protected from development such as highly productive agricultural lands, areas of high visual value, and critical environmental resources especially including lands critical to protecting the water quality of our rivers and streams. Much of this land would be wetlands.
2. This zone is intended to maintain the vegetation in this area.

(iv) Landscaping

1. Landscape buffers shall be provided between parking areas and adjacent residential, commercial, or industrial properties.
2. Landscaping shall be installed in all yard areas, along the perimeter of the lot, around buildings and all other portions of the property not specifically utilized otherwise.
3. Minimum Landscaping requirements:
 - a. Commercial, industrial, mixed-use, and multi-family projects shall comply with the following:
 - i. 50% of the required useable open space of the project shall be planted landscape area.
 - ii. Twenty trees shall be required per one (1) acre of gross land
 - iii. Fifty (50) shrubs shall be required per one (1) acre of gross land.
 - iv. Plant material shall be placed around the perimeter of the building foot print in a three (3) foot minimum planting strip with the exception of entrances, utilities and where setbacks are less than three feet.
 - v. Mulch or clean gravel is recommended in non-turf areas to retain water and encourage infiltration. Weed barrier fabrics or drainage fabrics placed under the mulch or gravel shall be porous material to allow water and air to infiltrate into the soils

below.

- b. Landscaping of Rights-of-way
 - i. All public or private streets shall provide a planted landscaped strip (park strip) and be perpetually maintained by the adjacent property owner.
 - ii. Street trees shall be planted within the parkstrip along both sides of all streets every thirty (30) feet on center.
 - iii. Residential park strips shall be planted with live plant material to a minimum of fifty percent (50%). When calculating the park strip coverage percentage areas, plants may be measured at mature spread excluding street trees.
 - iv. Impermeable surfaces such as asphalt or concrete are prohibited within the park strip.
- c. Parking Lot Landscaping
 - i. The parking lot perimeter landscaping requirements apply to all off-street parking lots that are not otherwise fully screened from view of the adjacent public rights-of-way. Parking Lot perimeter landscaping is governed by the City Land Development Code.
 - ii. The parking lot interior landscaping shall provide the following:
 - 1. At least 18 square feet of interior landscape planting area for each off-street parking stall.
 - 2. Landscaping located within the interior shall be evenly dispersed throughout the area.
 - 3. All aisles shall have landscaped areas at each end of the aisle.
 - 4. One landscaped planter area containing at least one (1) tree shall be installed within the interior of the parking area for every fifteen (15) stalls.

b) Infiltration BMPS

(i) At Grade Retention/Infiltration Basins

1. All retention basins shall be sized to meet the requirements of Section B of this chapter and to contain 100 percent of project site runoff from the design storm. Infiltration during the storm shall not be included in the calculation.
2. Side slopes shall not be steeper than 3:1 (H:V).
3. The maximum depth of the pond shall be three feet plus one (1) foot of

freeboard above the emergency overflow and a maximum water depth of three (feet) below the emergency overflow. All other ponds require special design, approval, and permitting including safety precautions on a case by case situation.

4. All ponds shall be stabilized with rocks or planted vegetation to prevent internal erosion. Vegetation or other stabilization shall be maintained.
5. All ponds shall drain within 3 days (72 hours) from the end of the storm event. This is to be documented with a certified percolation test of the native sub-grade material and the material placed during construction, and documented in the soils report.
6. Emergency overflows and the flow path of the overflows shall be mapped for purpose of flooding.
7. The emergency overflow shall be designed to pass the full 100 year event.
8. Other utilities (for example water lines, sewer lines, gas lines, power lines, phone lines, etc.) shall not be allowed through the retention pond or within 5 feet of the pond berms.
9. The invert or lowest point in the pond shall be not less than 24-inches above the historically highest groundwater levels.
10. The bottom of the pond shall be finished to maintain historical infiltration.

(ii) Underground Retention/Infiltration Systems

1. All retention basins shall be sized to meet the requirements of Section B of this chapter and to contain 100 percent of project site runoff from the design storm. Infiltration during the storm shall not be included in the calculation.
2. Underground buried retention and injections systems, are not allowed in drinking water source protection zones 1 and 2.
3. Underground systems shall provide adequate access points for cleaning and maintenance of the underground chambers.
4. All systems shall drain by infiltration within 3 days (72 hours) from the end of the storm event. This is to be documented with a certified percolation test and documented in the soils report.
5. Sumps shall provide adequate water quality treatment to prevent contamination of the ground water aquifer.
6. Emergency overflows and the flow path of the overflows shall be mapped for purpose of flooding and flood insurance requirements.
7. The emergency overflow shall be designed to pass the full 100 year event.
8. Other utilities (for example water lines, sewer lines, gas lines, power lines, phone lines, etc.) shall not be allowed through or under the underground retention system.

9. Registration with the DWQ and a Class 5 Injection Well Permit are required for all underground retention/infiltration systems.

(iii) Infiltration Trenches

1. Infiltration trenches are not allowed in drinking water source protection zones 1 and 2.
2. Infiltration trenches shall provide adequate access points for cleaning and maintenance underground piping.
3. Infiltration trenches shall drain by infiltration within 3 days (72 hours) from the end of the storm event to provide adequate storage for a subsequent event. This is to be documented with a certified percolation test and documented in the soils report.
4. Infiltration trenches shall have adequate water quality treatment to prevent contamination of the ground water aquifer.
5. Emergency overflows and the flow path of the overflows shall be mapped for purpose of flooding and flood insurance requirements.
6. The emergency overflow shall be designed to pass the full 100 year event.
7. Other utilities (for example water lines, sewer lines, gas lines, power lines, phone lines, etc.) shall not be allowed through or under the infiltration trenches.
8. Registration with the DWQ and a Class 5 Injection Well Permit are required for all infiltration trenches.

(iv) Infiltration Swales

1. Side slopes shall not be steeper than 4:1 (H:V).
2. The maximum depth of the pond shall be one (1) foot.
3. All ponds shall be landscaped per landscaping requirements. Vegetation or other stabilization shall be maintained.
4. All swales shall drain within 3 days (72 hours) from the end of the storm event. This is to be documented with a certified percolation test of the native sub-grade material and the material placed during construction, and documented in the soils report.
5. Emergency overflows and the flow path of the overflows shall be mapped for purpose of flooding to ensure all emergency overflows are to the PWD drainage system
6. The invert or lowest point in the pond shall be not less than 24-inches above the historically highest groundwater levels.
7. The bottom of the pond shall be finished to maintain historical infiltration.

8. Temporary check dams shall be constructed at 150' intervals during construction of a subdivision. May be removed when permanent driveway is installed within the lot the temp dam is constructed on.
9. Swales must be completed to final grade and top soil prior to final acceptance of a subdivision.

(v) Permeable Pavements

Permeable (or pervious) pavements contain small voids that allow water to pass through to a stone base. They come in a variety of forms; they may be modular paving system (concrete pavers, modular grass or gravel grids) or poured in place pavement (porous concrete, permeable asphalt). All permeable pavements with a stone reservoir base treat storm water to remove sediments and metals to some degree by allowing storm water to percolate through the pavement and enter the soil below. All permeable pavement systems shall be designed to ensure that water in the pavement and the rocks below completely infiltrate into the soil within 72 hours.

(vi) Injection Wells (Sumps)

1. Injection wells also known as sumps are not allowed in drinking water source protection zones 1 and 2.
2. Injection wells shall provide adequate access points for cleaning and maintenance underground piping.
3. Injection wells shall drain by infiltration within 3 days (72 hours) from the end of the storm event to provide adequate storage for a subsequent event. This is to be documented with a certified percolation test and documented in the soils report.
4. Injection wells shall have adequate water quality treatment to prevent contamination of the ground water aquifer.
5. Emergency overflows and the flow path of the overflows shall be mapped for purpose of flooding and flood insurance requirements.
6. The emergency overflow shall be designed to pass the full 100 year event.
7. Registration with the DWQ and a Class 5 Injection Well Permit are required for all injection wells.

c) Storm Water Harvesting

Storm water harvesting will not be considered a means of an acceptable permanent stormwater BMP.

d) Natural Filters

Natural Filter facilities are landscaped shallow depressions that capture and filter stormwater runoff. As stormwater passes down through the planting soil, pollutants are filtered, adsorbed, and biodegraded by the soil and plants. Because they are not contained within an impermeable structure, they may allow for infiltration.

Projects that have demonstrated they cannot manage 100% of the water quality design volume onsite through infiltration and/or stormwater harvesting BMPs may manage the remaining volume through the use of a high removal efficiency natural filter BMP. A high removal efficiency natural filter BMP shall be sized to adequately capture 1.5 times the volume not managed through infiltration and/or capture and use.

(i) Bio-Filters

Most natural filter systems can be classified as biofilters. They normally consist of a ponding area, mulch layer, planting soils, plants, and in some cases an underdrain. Runoff that passes through a biofiltration system is treated by the natural absorption and filtration characteristics of the plants, soils, and microbes with which the water contacts.

(ii) Rain Gardens

Rain gardens are simply gardens designed to capture and treat runoff. They are generally small in size and should not be used to treat impervious areas exceeding 4,000 square feet. Rain gardens most often utilize native plant species and soil amendments to encourage absorption of stormwater. For projects with impervious areas exceeding 4,000 square feet biofilters, planter boxes with infiltration, vegetated swales or natural buffer strips should be considered.

(iii) Planter Boxes with infiltration

Planter boxes with infiltration are natural filtration treatment control measures located in and around structures and facilities to handle larger volumes of water than a typical rain garden. They typically are constructed with vertical or near vertical sides and above

ground. They can be equipped with underdrains if necessary. Planter boxes with infiltration should maintain setbacks from adjacent buildings, other structures, sidewalks or roadways.

(iv) Vegetated Swales

Vegetated swales are open, shallow channels with dense, low-lying vegetation covering the side slopes and bottom that collect and slowly convey runoff to downstream discharge points. An effective vegetated swale achieves uniform sheet flow through the densely vegetated area for a period of several minutes. The vegetation in the swale can vary depending on its location and is the choice of the designer. Most swales are grass-lined.

(v) Filter or Buffer Strips

Filter strips are vegetated areas designed to treat sheet flow runoff from adjacent impervious surfaces such as parking lots and roadways, or intensive landscaped areas such as golf courses. While some assimilation of dissolved constituents may occur, filter strips are generally more effective in trapping sediment and particulate-bound metals, nutrients, and pesticides. Filter strips are more effective when the runoff passes through the vegetation and thatch layer in the form of shallow, uniform flow. Filter strips are primarily used to pretreat runoff before it flows to an infiltration BMP or another natural filtration BMP.

e) Man-Made Treatment

(i) Planter Boxes

Planter boxes are bioretention treatment control measures that are completely contained within an impermeable structure with an underdrain (they do not infiltrate). They are similar to bioretention facilities with underdrains except they are situated at or above ground and are bound by impermeable walls. Planter boxes may be placed adjacent to or near buildings, other structures, or sidewalks.

(ii) Hydrodynamic Separators

Hydrodynamic separators are stormwater management devices that work primarily based on vortex and gravity principles to separate stormwater from the pollutants. They are generally designed as flow-through systems with either on-line or off-line storage of pollutants. They include chambers for settling and storage of pollutants and are often used in conjunction with other BMPs as pretreatment. They are not especially effective for the removal of fine materials or dissolved pollutants. On-line separators are more susceptible to scour or re-suspension of pollutants than systems that incorporate off-line storage.

f) Settlement systems

Settlement systems are used to store and settle out sediment using Stokes Law. This approach does not infiltrate, harvest, or evaporate sufficient water. However, it can be used in combination with other BMPs to ensure treatment of water above

the 90th percentile storm to ensure water quality requirements and the flow requirements of the canal companies are met.

(i) At Grade Detention Basins

1. Side slopes shall not be steeper than 3:1 (H:V).
2. The maximum depth at the emergency overflow location of the pond shall be three feet plus one (1) foot of freeboard above the emergency overflow and a maximum water depth of three (feet) below the emergency overflow. All other ponds require special design, approval, and permitting including safety precautions on a case by case situation.
3. All ponds shall be stabilized with rocks or planted vegetation to prevent internal erosion. Vegetation or other stabilization must be maintained.
4. Where orifice and snouts are used, the orifice size is limited to not less than three (3) inches in diameter to prevent clogging.
5. Emergency overflows and the flow path of the overflows shall be mapped to natural streams, canals, or city approved drainage system for purpose of flood mapping using existing topographic mapping.
6. The emergency overflow shall be designed to pass the full 100 year event.
7. Other utilities (for example water lines, sewer lines, gas lines, power lines, phone lines, etc.) shall not be allowed through the detention pond or within 5 feet of the pond berms.
8. The invert or lowest point in the pond shall be not less than 12-inches above the historically highest groundwater levels (whichever is higher).
9. The bottom of the pond shall be finished to maintain historical infiltration.

(ii) Underground Detention Systems

1. Underground systems shall provide adequate access points for cleaning and maintenance.
2. All Detention systems shall drain by discharge (detention basins) within 3 days (72 hours) from the end of the storm event. This is to be documented.
3. Emergency overflows and the flow path of the overflows shall be mapped for purpose of flooding and flood insurance requirements.

4. The emergency overflow shall be designed to pass the full 100 year event.
5. Other utilities (for example water lines, sewer lines, gas lines, power lines, phone lines, etc.) shall not be allowed through or under the underground retention system.

8. Curb and Gutter Flow Design

1. The flow depth in the gutter shall not be allowed to exceed the lesser of the top back of curb elevation (TBC) or the peak drive way approach elevation during the required storm event. This includes a combination of piping, curb and gutter, and ditches.
2. Where the flow depth is exceeded, storm drain inlets and a piped system shall be required and appropriate actions taken to eliminate overtopping of the curbs and flooding private property.

9. Channel Design

1. Channel side slopes shall not be steeper than 3:1 (H:V) unless they are concrete. Where they are incorporated into landscaping, flatter slopes shall be required. This will be evaluated on a case by case basis.
2. Channel velocities shall be slow enough to prevent scour, and where possible, facilitate further settlement of sediments unless the channel is used to deliver irrigation water as well. If the channel will also carry irrigation water, maintain velocities above 2 ft/sec if possible, but at no time exceed 4 ft/sec.
3. Where rip-rap is used, design shall be in accordance with EM-1110 from the US Army Corp of Engineers or HEC-11 from the Federal Highway Administration.
4. Free board on the channels shall be in compliance with the Bureau of Reclamation, Design of Small Canal Structures.
5. Channel maintenance easements shall be maintained as required in the City and Canal Company agreements.

10. Pipe Design

1. For storm water pipes, roughness coefficients listed in the table included in Section D of these standards that coincide with the accepted pipe materials in the City's Standard Specifications, most current edition shall be used.

2. Maintain velocities in the pipes at design flows sufficient to prevent sediment deposition and low enough to prevent scour damage to the pipe.
3. Pipe outlets shall have a flared end discharge unless more stringent methods of energy dissipation are required.
4. Minimum diameter of storm drains shall be:
 5. 12 inches for laterals
 6. 15 inches for trunk lines
 7. 18 inches under the UDOT right of way.
8. Pipe sizes shall not decrease in the downstream direction.
9. Maximum flow depth in the pipe during the design storm shall not exceed 0.85 times the diameter of the pipe.

D. REQUIRED HYDROLOGIC METHODOLOGY

1. Design Methodology

Table C-1 summarizes the required methods based on the area contributing flows to the system, including offsite flows. THE RATIONAL EQUATION IS NOT ALLOWED FOR DESIGN OF BEST MANAGEMENT PRACTICES.

Table C-1, Hydrologic Methods Required

Contributing Area (Acres)	Methodology Required
Less than 10.0 Acre	SCS Method with calculated time of concentration. Time of Concentration shall not be less than 5 minutes.
Greater than 10.0 Acres	SCS Method. The time of concentration can be calculated or hydrodynamic solutions may be used. If hydrodynamic solutions are used, the model must be provided to the PWD for detailed review of all assumptions and data used.

2. Design Hyetographs

Table C-2 summarizes the hyetograph which shall be used during the design.

Table C-2, Required Design Hyetograph

Contributing Area (Acres)	Methodology Required
Less than 10.0 Acres	SCS Type II Storm
10.0 Acres or Larger	SCS Type II Storm or other acceptable Hyetograph with special approval.

3. Hydrologic Procedures

The SCS method, as developed in TR-55 by the Soil Conservation Service in the 1950s, requires the designer to address the soil conditions, vegetative cover, and the antecedent soil condition (AMC) being evaluated.

a) SCS Soil Conditions

Soil maps and references available from the Natural Resource Conservation Service will identify the group associated with each soil class. HOWEVER, the designer needs to consider the effects of the final landscaping, such as the use of top soil, as part of his design.

There are four primary soil conditions available in the SCS method, grouped as A, B, C, and D.

Group A soils typically are gravels and sands with fast infiltration rates and low runoff potential. While there are Group A soils on some of the benches and along the Logan river in some places, as soon as any landscaping with topsoil occurs, the storm water benefit is lost. Unless specific LID design is incorporated to maintain the infiltration potential of these soils, final landscaping will require a different soil group.

Group B soils have moderate infiltration rates when wetted and consist of moderately well drained soils with moderately fine to coarse textures, typically without clay.

Group C soils have slow infiltration rates if thoroughly wetted and consist of soils that have a layer that impedes vertical infiltration.

Group D soils have a slow infiltration rate if thoroughly wetted and consist of clays, usually with high swelling potential, soils with a permanent high water table, soils with a clay pan or hard pan later near the surface, and shallow soils over an impervious material.

b) Antecedent Soil Conditions

In addition to the soil group, the antecedent moisture condition (AMC) must also be considered. For the average case, the SCS has defined AMC II to apply as the definition of the conditions preceding most annual floods. For this purpose, AMC II will be used for all PWD approved projects.

Upon selecting the soil group, the appropriate curve number can be selected from various standard references and text books. A common free reference is the HEC-HMS technical reference manual which can be downloaded from the Army Corp of Engineers HEC website. Runoff coefficients are subject to approval by the City Engineer.

c) Runoff Coefficients

PWD has established standard runoff coefficients that shall be used to ensure compatibility of results from the base model and each individual project.

Calculations differing from these values shall be returned to the design professional for corrections.

Table C-3, Required Runoff Coefficient (CN)

Condition	Soil Group A	Soil Group B	Soil Group C	Soil Group D
Asphalt	98	98	98	98
Concrete Pavement	98	98	98	98
Grassed Open Space (Grass Cover > 75%)	39	61	74	80
Grassed Open Space (Grass Cover 50-75%)	49	69	79	84
Graveled Areas	76	85	89	91
Woods and Forested Areas (Good Condition)	25	55	70	77
¹⁾ Residential Lots, less than ¼ acre	77	85	91	94
¹⁾ Residential Lots, ¼ acre to ½ acre	61	75	83	87
¹⁾ Commercial Business Areas	89	92	94	95
¹⁾ Industrial Areas	81	88	91	93

¹⁾ Where the weighted values are too cumbersome to calculate, or insufficient data is available outside of the project area, use these values.

d) Time of Concentrations Calculations

There are numerous equations for calculating the time of concentrations. While many may be applicable to various locations, Table C-4 identifies the methods that shall be used in determining the time of concentrations within the PWD areas.

Table C-4, Time of Concentration Calculations

Larger of Contributing Area or Project Area (Acres)	Sheet Flow	Open Channel Flow	Piped Flow
Less than 10.0 Acres	Calculated per HEC-22	Calculated per HEC-22	Calculated per HEC-22
10.0 Acres or Larger	Coordinate with City Engineer	Coordinate with City Engineer	Coordinate with City Engineer

E. HYDRAULIC CALCULATIONS

Hydraulic calculations shall be used for sizing pipes and open channels associated with the total design flows.

1. Channel Design

Channels shall be designed with a trapezoidal cross section using roughness coefficients associated with the final restored condition. The Manning's equation methodology shall be used for sizing and considering the associated backwater impacts from downstream conditions. Computer software can be used to calculate the channel size, but sufficient data and results shall be provided to validate the procedure, assumptions, and conclusions.

2. Pipe Design

For design of pipes and culverts, the designer shall demonstrate that the pipes meet the standard design requirements using Manning's equation for open channel flow and standard culvert calculation procedures to determine inlet and outlet control conditions. Full pipe flow designs are not allowed for gravity systems. For storm water pressure mains from pump stations, either the Hazen-Williams or Darcy-Weisbach equations will be allowed. Roughness coefficients and assumptions shall be in accordance with Table D-1 selected from various references.

Pipe material: shall be Reinforced Concrete Pipe (APWA 33 05 02) or Polyethylene Pipe (APWA 33 05 06) or Polypropylene (APWA 33 05 11).

Required cover shall follow manufacturers recommendations, but in no case shall be less than 12" without prior approval from City Engineer.

Due to many places in the City having high ground water, flotation and buoyancy calculations are required on all Poly pipe installations, and counter measures designed if calculations show a risk of the pipe floating.

Table D-1, Manning's Coefficients for Pipe

Material	Roughness "n"
Smooth Interior HDPE or PE Pipe	.010
Reinforced Concrete	.013

The design and sizing may be done manually or with the use of computer software. However the results must be provided as part of the submittal review process.

3. Spread Width Calculations

Spread width calculations and depth of flow in the gutters shall be completed in accordance with HEC-22 methodology developed by the Federal Highway Administration (FHWA). These calculations can be completed using numerous available software or manually. However, the calculations must be documented and provided to the City for review for the design storms.

Section 7. Other Utility Systems

- 7.1 Monuments.** Permanent monuments shall be accurately set and established within the subdivision at such points and to the specifications determined by the City Engineer as necessary to definitely establish all the lines of the plat and individual lots.
- A. All subdivision plats shall be tied to two corner or monuments of record or established land office survey corners, as well as the Nibley City Monument System.
 - B. Curb pins shall be placed in the center of the top of curb at locations where the property lines would intersect the curb if they were to extend to the centerline of the road.
- 7.2 Natural Gas Service.** Natural gas mains and laterals shall be installed to each lot, to the lot line.
- 7.3 Electric Power Service.** Underground electrical conduits shall be installed to each lot, to the lot line.
- 7.4 Street Lighting.** Street lights shall be shown on construction plans, and required every:
- A. Five hundred feet (500') throughout the subdivision;
 - B. At all intersections;
 - C. At the back of each cul-de-sac.
- 7.5 Street Signs.** Street signs shall be paid for by the developer as part of the Development Agreement. City staff shall order the signs and install the street signs.

Section 8. Transportation Standards

8.1 Additional Referenced Standards. Design of street and related improvements in Nibley City shall conform to these Design Standards, Nibley City Standard Construction Specifications, and certain sections (as required by the City Engineer) of the current edition of the following referenced standards or documents:

- A. “A Policy on the Geometric Design of Highways and Streets” American Association of State Transportation and Highway Officials (AASHTO)
- B. “Manual on Uniform Traffic Control Devices (MUTCD) for streets and highways” US Department of Transportation Federal Highway Administration
- C. “Guide for the Design of Pavement Structures” American Association of State Transportation and Highway Officials (AASHTO)
- D. “Roadside Design Guide” American Association of State Transportation and Highway Officials (AASHTO)
- E. “Standard Specifications for Highway Construction” Utah Department of Transportation (UDOT)
- F. Uniform Fire Code
- G. American Public Works Association Manual of Specification and Plans

8.2 Street Classification and Rights of Way Width. The Nibley City Transportation Master Plan shall establish street classifications. In the event that the Transportation Master Plan does not provide sufficient information in determining a classification, the City Engineer shall make a final determination.

A. Local Streets

- 1. Serve up to 75 residences
- 2. Serve an ADT of 750 or less
- 3. Shall have a minimum of a 60-foot right of way, unless listed on the Master Street Plan Map, then must comply with 8.3 (C).

B. Collector Streets

- 1. Serve over 75 residences
- 2. Serve an ADT between 750 and 4000
- 3. Designated in the Transportation Master Plan or General Plan
- 4. Shall have a minimum of 66-foot right of way

C. Arterial Streets

- 1. Designated in the Transportation Master Plan or General Plan
- 2. Shall have a minimum of 80-foot right of way

8.3 Standard Street Cross Sections.

- A. Street Cross Sections shall conform to the following table and section with cross sections in the Transportation Master Plan Chapter 5.

Typical Section	Description	Street Classification	Right-of-way Width (feet)	Applicable Streets
TS-1	3-Lane Street with Buffered Bike Lane	Arterial	99	Heritage Drive, 4400 South, 3200 South
TS-2	3- Lane Street with Trail Facility			
TS-3	2- Lane Street with Buffered Bike Lane And Trail Facility	Arterial	80	2600 S (East of Railroad); 1200 W
TS-4	2-Lane Street with Buffered Bike Lane	Arterial	80	1900 W
TS-5	2-Lane Street with Trail Facility	Arterial	80	4000 South, 2600 South (West of 1200 W)
TS-6	2-Lane Street (No Bike Facility)	Arterial	80	2500 West
TS-7	2 Lane Street with on street parking	Collector	66	1000 W, Other collector within subdivision
TS-8	2 Lane Street with Bicycle Boulevard	Collector	66	250 W,
TS-9	2 Lane Street (No Bike Facility)	Collector	66	3650 S; Nibley Parkway; 2200 South; 1700 West; 1500 West; 900 West (South of 3200 South); 900 West (2600 South to 900 West); 700 West (South of 4000 South); 250 East
TS-10	2-Lane Street with Trail Facility	Collector	66	800 West (North of 2600 South); 640 West (4000 South to 3200 S)

:

B. All neighborhood and local streets within a subdivision shall comply with TS-13 in the Transportation Master Plan, or TS-14 if the developer or City wishes to incorporate swales. The City may allow the use of TS-11 when there is a proposed Trail use within the Trails Master Plan or proposed as part of a development. TS-12 may be approved in limited

circumstances to access a residential development, or an industrial or commercial facility. TS-12 may also be used in town-home, condominium or Residential-Planned Unit Developments as long as sufficient parking is provided in parking courts, dedicated sections of on street parking, driveways, and garages.

- C. Local Collector roads are roads labeled within the Master Street Plan Map as local roads. These roads shall be built to 66 right-of-way width. TS-7 shall be the default cross-section. The Public Works director may allow other cross-section for local collectors based on 8.3 (D)

- D. The City Public Works Director may adjust the layout of the above listed cross sections for Low Impact Development, increase safety, or to achieve other goals that are contained in the General Plan, Transportation Master Plan, Trails Master Plan, or the master/development plan of a subdivision.

- 1. Examples of reason why a cross-section would be altered include some of the following: increase width of sidewalks or bike lanes, increase width of proposed swales, eliminating street parking where sufficient parking will be located in parking court or lot or to allow for bicycle or pedestrian facilities, etc.

- E. Right-of-way widths must comply with right-of-way widths listed in the Transportation Master Plan. The Public Works director may approve a wider right-of-way if necessary, for traffic, Low Impact Development, or to improve the function of an intersection.

8.4 Street Design Speeds Design considerations for all street geometrics shall reflect the following design speeds. Variances from these design speeds shall be approved by the City on a case-by case-basis.

- A. Shall normally be as follows: Design Speed/ Posted Limit

- 1. Local 30 mph /25 mph
 - 2. Collector Streets 30 mph/25 mph
 - 3. Arterial Streets 40 mph/35 mph

- A. Design of controlled intersections shall conform to applicable requirements Referenced Standards listed in Section 6.1 of these Design Standards.

8.5 Street Geometric Design. Design of vertical and horizontal curves, and super-elevated street sections shall be to AASHTO Standards as referenced herein. Horizontal and vertical curves for a given street shall reflect the design speed of the particular classification of the street.

- A. Horizontal Alignment. Horizontal alignment and curvature shall be calculated in accordance with AASHTO’s “Policy for the Geometric Design of Highways and Streets.”
- B. Horizontal Curve.
 - 1. Horizontal curve radii shall be computed using the above named AASHTO guide, but shall be restricted to the following minimum center-line curve radii with 0% super elevation and standard friction factors.
 - a. Local 100 ft
 - b. Collector and Arterial Design pre-AASHTO guide
 - 2. Horizontal centerline of improvements shall be parallel to the centerline of the right-of-way.
 - 3. The centerline of proposed street extensions shall be aligned with the existing street centerline.
 - 4. Sharp horizontal curvature should not be introduced at or near the top of a pronounced crest.
- C. Vertical curve.
 - 1. Sharp horizontal curvature should not be introduced at or near the low point of a pronounced sag vertical curve.
- D. Vertical Alignment
 - 1. Vertical curves are required at changes in grade greater than 1.5%.
 - 2. Streets intersecting a Collector or Arterial Street shall be provided with a Landing averaging 5%, or less. Landings are that portion of the street within 20-feet of the nearest curb on the intersecting street at its required design full improvement width.
 - 3. Street grades, intersections, and super elevation transitions shall be designed to not allow concentrations of storm water to flow out of the gutter, across the street, or in a manner that is unsafe for vehicular travel.
 - 4. Vertical curves shall normally provide for desirable stopping sight distance, but shall at least provide for minimum stopping sight distance.
 - 5. Vertical curves shall be parabolic and of a minimum length computed from the formula:
 - a. $L = K * A$
 where:
 L = length of vertical curve in feet
 K = design constant (rate of vertical curvature)
 A = algebraic difference in grades, in percent
 - 6. “K” is a constant for each design speed; its selection for crest vertical curves is based on stopping sight distance (SSD) requirements and, for sag vertical curves, on headlight sight distance. K values to be used for the design of vertical curves are as follows:

Design Speed MPH	Crest Minimum	V.C. SSD Desirable	SAG Minimum	V.C. SSD Desirable
20	10		20	
25	20		25	
30	30	30	35	35
35	40	50	45	50
40	60	80	55	70

E. Super-elevation. The maximum super-elevation rate permitted on City streets shall be:

1. Local 4%
2. Collector 4%
3. Arterial 6%
4. Super-elevation design shall meet all requirements for vertical alignment and shall be reviewed on a case-by-case basis.

F. Intersections.

1. The interior angle at intersecting street shall be kept as near to 90 degrees, or perpendicular to the intersecting street, as possible. In no case shall the interior angle be less than 80 degrees for a distance of 100 feet.
2. Standard Top Back Curb radii at intersections are as follows:
 - a. Local/Local 12 ft
 - b. Local/Collector 12 ft
 - c. Collector/Collector
 - d. Collector/Arterial
 - e. Arterial/Arterial
3. ADA sidewalk ramps shall be provided at all intersections

G. Street Grades & Slopes.

1. Maximum grade on streets shall be as follows:
 - a. Arterials 6%
 - b. Collectors 8%
 - c. Residential 12%
 - d. Neighborhood 12%
2. Minimum grade
 - a. On streets shall be 0.4%
 - b. On a curve or curb radius less than 30 feet shall be 0.5%
3. Cross slope
 - a. Minimum 2%
 - b. Maximum 4%
4. Intersections
 - a. Street grades at intersections shall be no greater than 2% for at least 50 feet from the center of the intersection.

8.6 Pavement Structural Design. Pavement structure design for all streets shall be per AASHTO standards for pavement design.

A. All laboratory test results required in the AASHTO procedure shall be provided to the City Engineer

- B. Roadway structural section is dependent on subsurface conditions and traffic volume. They shall be determined by developer's licensed geotechnical engineer and approved by the City Engineer. A soils investigation shall be submitted that includes:
 - 1. Soil borings along roadway centerline and other areas as needed
 - 2. Analysis on the overall bearing capacity of the soil
 - 3. Recommendation for structural street cross section
 - 4. Recommendation as to the requirements for land drains to adequately collect groundwater which could adversely affect development
 - 5. Cut and fill slope requirements
 - 6. Compaction requirements
 - 7. A geotechnical analysis shall be performed to determine the structural section. However, the minimum section shall be 3" Asphalt, 6" Untreated Base Course and 8" Structural Fill.
- C. Pavement structure design for all streets shall be per AASHTO standards for pavement design and the following design parameters:
 - 1. Minimum Level of Reliability:
 - a. Arterials – 95
 - b. Collectors – 90
 - c. Local – 80
 - 2. Design Life – 20 years on all roads
 - 3. Minimum CBR Value for Materials:
 - a. Granular Borrow – 30
 - b. untreated Base Course – 70
 - 4. Design Loads – All roads shall account for a minimum of 5% trucks
 - 5. Mix Design shall meet APWA 32 12 03 30% RAP Mix Design with a target binder grade of PG58-28.

8.7 Concrete Curbs

- A. Required Concrete Curb Types
 - 1. APWA Type "A" Curb and Gutter shall be installed on all new construction.
 - 2. Ribbon Curb per Nibley amendments to APWA Standards

8.8 Driveways

- A. Driveways -
 - 1. Single Family Dwellings in developed area's shall be limited to one driveway. Corner lots may be allowed two driveways, one driveway per fronting street.
 - 2. Multi-family Dwelling, Apartments, Industrial, and Commercial properties shall be limited to two driveways.
 - 3. One-way driveways shall be no closer than 75-feet between their nearest edges.
 - 4. Corner properties of less than 75-feet frontage on a collector or arterial street shall have no driveway located on the collector or arterial street.

5. All proposed commercial businesses shall be limited to two access points to a public right of way
 6. Commercial Driveways shall be located a minimum of 200-feet from the centerline of an intersection with a collector or arterial street.
 7. Residential Driveways shall be located a minimum of 100-feet from the centerline of an intersection.
 8. Maximum width shall be 24 feet from bottom of curb cut to bottom of curb cut
- B. Driveways on Arterial streets
1. Not allowed with out prior approval from Public Works Director
 1. One-way driveway entrances onto an arterial Street shall be located a minimum of 125-feet from a downstream intersection, and no closer than 75-feet from an upstream intersection
 2. One-way driveway exits shall be located a minimum of 75-feet from the downstream intersection and no closer than 125-feet from an upstream intersection
- C. Driveway Turnaround
1. Should the length of a residential driveway be greater than 150-feet and the driveway have only one access to the street or does not loop to the street, an approved turnaround meeting Nibley City and Uniform Fire Code standards shall be provided

8.9 Cul-de-Sac

- A. Length
1. Shall conform to the Nibley City Subdivision ordinance and shall be measured from the center of the cul-de-sac radius to the center of the right of way on the street perpendicular to the street of the cul-de-sac.
- B. Radius
1. Turnaround area pavement shall have a min radius of 44.5 feet to edge of asphalt.
- C. Curb, gutter, sidewalk and planting strip within the turnaround area shall remain the same as the road cross section leading into the turnaround.
- D. Temporary
1. Where a street is designed to remain only temporarily as a dead - end street, an adequate temporary turning area shall be provided at the dead end thereof to remain and be available for public use so long as the dead end exists.
 2. Shall meet Nibley City and Uniform Fire code standard radius requirements.
 3. Shall be hard surfaced with concrete or asphalt
- E. Partial cul-de-sacs
1. Not allowed

8.10 Speed Humps or Bumps

- A. Not allowed in a public right of way

8.11 Partial Streets (tie ins)

- A. Minimum tie in asphalt section shall be 3' wide
- B. Tie in section of asphalt shall have same structural pavement cross section as existing street
- C. Off set crowns shall not be allowed more than two feet from center or crown of street

- D. Longitudinal joints shall not be in direct wheel path
- E. Angle of deflection at tie other than crown, shall be 2% max
- F. Tie in section shall provide for proper drainage to curb or swale
- G. All asphalt tie in shall be to a clean newly cut line in existing asphalt

8.12 Winter Time Restriction

- A. No asphalt roadway section shall be cut or removed during the months of November to May, except for emergencies as determined by Public Works Director

Section 9. Landscape and Irrigation Systems

9.1 Sprinkler Design

- A. Sprinkler designs must be submitted and approved as part of construction documentation during subdivision review process.
- B. Sprinkler designs shall be designed not to spray over any hard surfaces on any property that will be owned and maintained by Nibley City.

9.2 Landscape Plan

- A. Landscape plan must be submitted and approved as part of construction documentation during subdivision review process.

Section 10. APWA Standard Details and Specifications

10.1 APWA 2017

- A. Nibley City has adopted the 2017 APWA Standard Plans and Specifications, with the following amendments:

10.2 Changes to Definitions:

- A. ENGINEER shall be defined as Nibley City City Engineer.

10.3 Changes to APWA Standard Details

- A. Part 1 – General Requirements
 - 1. Plan No 121 -Straw Bale Barrier
 - a. Not Allowed
 - 2. Plan No 122 – Silt Fence
 - a. 14 Gage 6 Inch Wire Mesh not required
 - 3. Plan No 124 – Inlet Protection – fence or Straw Bale
 - a. Straw bale not allowed
 - 4. Plan no 126 - Stabilized Roadway Entrance
 - a. Sediment fabric under the gravel not required
- B. Part 2 – Roadways
 - 1. Plan No 205 – Curb and Gutter
 - a. Remove note 2.B and note 3.B.1
 - b. Remove Expansion Joint at beginning and end of radi
 - c. Remove dowelled cold joint at new to old transition
 - d. Add Type I Ribbon Curb
 - 1. Curb shall have a Min 2% flow away from the street
 - 2. Curb shall have a Max 4% flow away from the street
 - 3. Curb shall be 18 inches wide
 - 4. Curb shall be 10 inches thick
 - 5. Two Number 4 bars running throughout the curb
 - 6. Shall have a min of 8” Grade ¾” Untreated Base Course compacted to 95% relative to a Modified proctor density
 - 2. Plan No 206 – Curb and Gutter Connection
 - a. Not required
 - 3. Plan 209 - Curbs
 - a. Remove note 2.B. and note 3.B.1.
 - b. Remove Expansion Joint at beginning and end of radi.
 - c. Remove Dowelled Cold Joint at new to old transition.
 - 4. Plan No 225 - Open Driveway Approach
 - a. Not allowed without pre approval in writing by Public Works Director.
 - 5. Plan 229 - Bridge Driveway Approach
 - a. Not allowed without pre approval in writing by Public Works Director.
 - 6. Plan 235 - Corner Curb Cut Assembly
 - a. Per note 1.B., Curb Return Alternate not allowed without pre approval in writing by Public Works Director.
 - 7. Plan No 236 - Mid Block Curb Cut Assembly

- a. Per note 1.B., Curb Return Alternate not allowed without pre approval in writing by Public Works Director.
- 8. Plan No 238 - Detectable Warning Surface
 - a. Remove Note 2.A., 2.B. and 2.D., not allowed.
 - b. Color of panels to be Colonial Red
- 9. Plan No 254 - Patch Repair - in place hot reused asphalt paving
 - a. Flowable fill not allowed without pre approval in writing by Public Works Director
- 10. Plan No 255 - Asphalt Concrete T-Patch
 - a. Flowable Fill not allowed without pre approval in writing by Public Works Director
- 11. Plan No 292 - Street Name Sign Post
 - a. City to order and install all street signs, cost to be paid for by developer in development agreement
- C. Part 3 – Storm Drain
 - 1. Plan No 302 - 30” Frame and Cover
 - a. This style not allowed
 - 2. Plan No 360 - Raise Frame to Grade
 - a. Cast iron grade rings allowed, max 12”
 - 3. Plan No 381 - Trench Backfill
 - a. Do not use flowable fill without written prior approval by Public Works Director
 - 4. Plan No 382 - Pipe Zone Backfill
 - a. Do not use flowable fill without written prior approval by Public Works Director.

SEE REDLINED MODIFICATIONS TO APWA WATER AND SEWER DETAILS AT THE END OF THESE STANDARDS

THIS PAGE LEFT BLANK INTENTIONALLY

THIS SECTION LEFT BLANK INTENTIONALLY

- F. Part 6 – Irrigation and Landscaping
 - 1. Plan No 613 - Irrigation Diversion Box
 - a. Irrigation diversion boxes will be reviewed and approved by respective canal company
 - 2. Plan No 614 - Irrigation Diversion Box
 - a. Irrigation diversion boxes will be reviewed and approved by respective canal company
 - 3. Plan No 621 - Stationary Head
 - a. Unless otherwise approved in writing by Public Works Director, use pop up head
 - 4. Plan No 622 - Pop Up Head
 - a. Type N nozzle head - use Hunter PRS 30 or Hunter PRS 40
 - b. Type R rotor head - use Hunter 4 inch I20 or 6 inch I25
 - c. Flexible swing pipe to be 12 inch minimum, 24 inch maximum
 - d. Use spiral barb fittings for less than 8 gallons per minute
 - e. Greater than 8 gallons per minute, to be designed and proposed by contractor for written approval by Nibley City Public Works Director, before installation
 - 5. Plan No 631 - Backflow Preventer (less than 3 inch diameter)
 - a. Stop and waste to be Muller brand surrounded by 6 inches of 1 inch minus gravel material, wrapped in a filter fabric
 - b. Backflow preventer device to proposed by contractor for written approval by Nibley City Public Works Director, before installation
 - c. Enclosure required, to be proposed by contractor for written approval by Nibley City Public Works Director, before installation
 - 6. Plan No 631 - Backflow Preventer (3 inch diameter and larger)

- a. Backflow preventer device to proposed by contractor for written approval by Nibley City Public Works Director, before installation
- b. Enclosure required, to be proposed by contractor for written approval by Nibley City Public Works Director, before installation
- c. Sleeve pipe penetrations through concrete pad
- d. 12” minimum clearance from edge of enclosure to edge of concrete pad all sides
- e. Frost prevention not required
- 7. Plan No 632 - Drain Valve
 - a. Manual drain valves to be proposed by contractor for written approval by Nibley City Public Works Director, before installation
 - b. Automatic drain valves not allowed
- 8. Plan No 633 - Control Valve
 - a. Valves larger than 2 inch to proposed by contractor for written approval by Nibley City Public Works Director, before installation
 - b. Automatic control valve to be a 1 inch or 2 inch Hunter ICV
 - c. Place concrete pavers under bottom edge of ground box
- 9. Plan No 651 - Wire Runs for Landscape Irrigation
 - a. All control wires to be ran inside appropriately sized pvc conduit, placed between 1 to 4 inches below sprinkler lines (when ran parallel)
- 10. Plan No. 681 – Tree
 - a. Typical tree staking detail is not allowed. Instead use 2 inch diameter wood stakes that are 8 feet in length. Drive a minimum of two stakes vertical and embed a minimum of 2 feet below tree hole. Ensure that stakes are not driven through root ball. Use a minimum of two V.I.T. cinch ties to secure tree to wood stakes. Top cinch tie to be with in 6 inches of main branching of tree. Drive stakes parallel to prevailing wind direction.
- G. Part 7 – Communications, Lighting, Traffic Control, Power
 - 1. All street lighting to be designed and meet Rocky Mountain Power Standards and specs.
 - 2. Traffic signals to be designed by Professional Engineer as part of construction Drawings.

Section 11. Amendments to APWA Standard Specifications

11.1 33 08 00 Commissioning of Water Utilities

1. Add line to Table 3- for Sewer Laterals, tests required: Exfiltration and CCTV
2. Add Column for CCTV: Sanitary Sewer mains and laterals and stormwater to Table 3 in section 3.10.a.

Section 12. Construction Inspection and Acceptance Summary

This section is intended to be a summary and may not be all inclusive.

12.1 Part 1 Partial Acceptance Inspections - This inspection is intended to insure that all buried public infrastructure (water, sewer, storm drain) and at grade storm water facilities are constructed according to the plan approved by the City Engineer and to Nibley City Standards and Specifications. Key points of this inspection include, but are not limited to:

***Note: No person shall operate or turn a Nibley City water system valve, unless he or she is explicitly employed by the City of Nibley. ***

- A. Acceptance Testing per APWA
- B. Review of approved SWPPP (including required self-inspections)
- C. GPS (by city staff) of all buried fittings, bends, tee's, valves, thrust blocks, etc.
- D. Water System
 1. Periodic visual inspection of construction process and materials
 2. Visual inspections required
 - a. All tie in locations
 - b. Fittings and Thrust blocks
 3. Water Main Commissioning Report Required
 - a. Pressure Testing
 - b. Bac-T Testing
 - c. Tracer Continuity Test
- E. Sewer System
 1. Periodic visual inspection of construction process and materials
 2. Commissioning Report
 - a. Low Air Pressure Test
 - b. Obstruction and Deflection test
 - c. Tracer Continuity Test
 - d. Sewer Video Inspection (to be done just prior to asphaltting surface)
- F. Storm Water System
 1. Grades and slopes of ponds, elevations, inlet and outlet structures
 2. GPS (by city staff) of all storm water pertinences

12.2 Part 2 Partial Acceptance Inspection - This inspection is intended to ensure that open space amenities (trails, parks, etc.) and roadways (minus the asphalt and sidewalks) are constructed according to the plan approved by the City Engineer and to Nibley City Standards and Specifications. Key points of this inspection include, but are not limited to:

- A. Acceptance Testing per APWA
- B. Review of approved SWPPP (including required self-inspections)
- C. Proof roll test of native base material, with a loaded ten wheel dump truck
- D. Visual inspection required
 - 1. When laying and compacting base course materials
 - 2. When laying geo fabric or grid
 - 3. When compaction tests are taken by contractor's representative
- E. Compaction Reports required per APWA
- F. Sewer Video Inspection shall be done at this time, just prior to placing of asphalt
- G. Pre Paving Meeting

12.3 Part 3 Partial Acceptance Inspection - This inspection is intended to ensure that Asphaltting of the roadway surface and the construction of sidewalks are in accordance with the plan approved by the City Engineer and Nibley City Standards and Specifications. Key points of this inspection include but are not limited to:

- A. Acceptance Testing per APWA
- B. Review of approved SWPPP (including required self-inspections)
- C. Asphalt Construction Report
- D. Sidewalk Compaction Report
- E. Visual inspection required of sidewalk forms prior to placing of concrete
- F. ADA ramp requirements

12.4 Final Acceptance Inspection - This inspection is intended to be an all-inclusive inspection of the public infrastructure. At this time, the Public Works Director and Division Managers within the department will come to the site together to conduct the Final Acceptance Inspection. The Contractor or his/her representative must be present. All infrastructure will be re-inspected at this time. Key points of this inspection include but are not limited to:

- A. Review of approved SWPPP (including required self-inspections)
- B. Acceptance testing per APWA
- C. Water System
 - 1. Fire Hydrants will be opened and closed
 - 2. All valves will be checked for vertical alignment of the valve box, that it is free of debris and at proper grade
 - 3. Meter barrels and lids will be checked for proper grade
 - 4. Meter Setters will be turned on and off and checked for placement in center of barrel
 - 5. Review of Water Commissioning Report
- D. Sewer System
 - 1. Manholes are not leaking at joints
 - 2. No debris left in manholes

3. Vented lids with "Sewer" inscribed on them
4. Lids are within 1 inch of asphalt grade
5. Connections are not leaking and at proper grade
6. Steps installed properly
7. Review of Sewer Commissioning Report

E. Storm Water

1. Catch basins are free of debris
2. Inlet/Outlet grates are properly installed
3. Orifice plates properly installed
4. Overflow's constructed per plan
5. Landscaping completed per plan

F. Curb and Gutter

1. No low spots per flood test
2. No cracking/spalling
3. Backfilled properly behind curb

G. Sidewalk

1. No cracking/spalling
2. No finish deformities (footprints)
3. Proper cross slope
4. Proper slopes and area's on ADA pedestrian ramps
5. Both edges backfilled properly

H. Asphalt

1. Asphalt 1/4" above lip of gutter
2. Asphalt Construction Report
3. No puddles

I. Final Grading and Backfill

1. Area between sidewalk and curb backfilled with min 6" top soil
2. Area behind the sidewalk properly backfilled and graded to existing surfaces
3. Construction debris removed from site

12.5 Issue Final Inspection Report (punch list)- Upon completion of the Final Acceptance Inspection, the Public Works Director shall issue an Inspection Report, detailing any deficiencies that need to be corrected. The developer shall have 30 days to complete the repairs, after such date the City reserves the right to repair the deficiencies by utilizing the financial Guaranty issued to the City by the Developer, per City Ordinance.

12.6 As-Built Drawings submitted- As - Built drawings shall be required as outlined in the Subdivision Ordinance, before an Improvements Completion and Acceptance Report will be issued.

12.7 Guaranty Period- The Guaranty period unless otherwise stipulated by the City, shall be a minimum of one year from the date of the issuance of an Improvements Completion and Acceptance Report.

12.8 Improvements Completion and Acceptance Report- This report will be issued to the Developer by the Public Works Director when the completed Subdivision has passed all required inspections, and all stipulations of the Subdivision Ordinance have been met, and is ready to be accepted by the City as public infrastructure. The date of the issuance of this report will begin the one year Guaranty Period.

12.9 End of Warrantee Inspection - This inspection is intended to find any defects in workmanship or construction that become evident during the Guarantee Period. It is the responsibility of the Developer to schedule the Final Inspection after the Guarantee Period has elapsed. If any defects are discovered during the inspection, the Developer shall have 30 days to complete the repairs, after such date the City reserves the right to repair the deficiencies by utilizing the Financial Guaranty issued to the City by the Developer, per City Ordinance. At this time, the site should be stabilized and a N.O.T. filed with the state and a copy submitted to the City. If no deficiencies are discovered, or they are repaired as specified, the City shall release the Warrantee Bond.

Section 13. Bridge Standards

13.1 Professional Engineer - All design shall be performed by or under the direction of a professional structural engineer.

- A. The following design standards shall be used:
 - 1. UDOT Structures Design and Detailing Manual including all applicable hydraulic capacity design standards.
 - 2. UDOT Bridge Standard Drawings
 - 3. AASHTO LRFD Bridge Design Specifications, current edition, with current interims.

Section 14. Secondary Water System

14.1 Design of secondary Systems

- A. Not allowed in Public Right of Way or Public Utility Easement
- B. Purple pipe required
- C. Cased when main lines cross public right of way
- D. Provide proper swing joint
- E. Register system with City, current contact info of system manager
- F. Written canal company approval
- G. Yearly certified backflow inspection

Section 15. Private Infrastructure Standards

15.1 Design of Private Infrastructure

- A. Private infrastructure shall be designed and constructed to meet all City Standards.

Section 16. Standard Details and Modifications to APWA Standard Plans

16.1 Water Details

16.1 Sewer Details

16.1 Water Details

Abbreviations and symbols for water

1. **GENERAL**

- A. Lettering Size: 10 point at final production.
- B. Lettering Style. Capital letters preferred.
- C. Existing Improvements. Shown in light shaded dashed line.
- D. New Improvements. Shown in solid continuous line.

2. **PRODUCTS** (Not used)

3. **EXECUTION** (Not used)

SYMBOLS	DEFINITIONS
	CENTER LINE
	CONSTRUCTION CENTER LINE
	PROPERTY OR R/W LINE
	EASEMENT LINE
	MONUMENT LINE
	FENCE
	CONTOUR LINE
	CONTOUR ELEVATION
	BANK SLOPES
	STORM DRAIN LINE
	WATER LINE
	GAS LINE
	TELEPHONE CABLE
	ELECTRIC CABLE
	SANITARY SEWER LINE
	ASPHALT PAVING
	FIRE HYDRANT
	WATER VALVE
	WATER METER
	MANHOLE
	CATCH BASIN
	CLEANOUT BOX
	POLE AND ANCHOR
	STREET LIGHT
	UNDISTURBED EARTH
	STRUCTURE

SYMBOLS	DEFINITIONS
	CURB & GUTTER
	SIDEWALK
	RAILROAD TRACKS
	GUARD RAIL
	OPEN DITCH, CANAL
	CULVERT
	SECTION CORNER
	SOIL BORING
	MONUMENT
	BM NO. 46 ELEV. 4256.50
	SIGN
	POWER POLE
	TELEPHONE POLE
	DECIDUOUS TREE
	CONIFEROUS TREE
	P.I.
	P.C. OR P.T.
	PROFILE
	GROUND PROFILE
	ROUND ARCH BOX CULVERT
	P.V.I.
	P.V.C. OR P.V.T.
	GROUND WATER ELEVATION

NOTE:

EXISTING FACILITIES MAY BE SHOWN IN SCREENED OR DASHED LINES

27" Frame and cover

1. GENERAL

A. This frame and cover fits manholes in Plan 505.

2. PRODUCTS

A. Castings: Grey iron class 35 minimum, ASTM A48, coated with asphalt based paint or better (except on machined surfaces).

1) Cast the heat number on the frame and cover.

2) Give the frame and cover a machine finish so the cover will not rock.

3) √ designates machined surface.

4) Cast the name of the agency or its acronym as the first line. Cast the word "WATERWORKS" as the second line. Cast the word "Valve" (or applicable word) as the third line. Cast all letters on the cover in upper case flush with the surface finish.

3. EXECUTION (Not used)

Nibley City Amendments:

1. Only allowed on 21" meter cans that house 1" meters.

2. Must be constructed with a 2" recessed hole to mount a meter antenna.

3. See the Nibley City Approved Materials List for information on specific product types and manufactures.

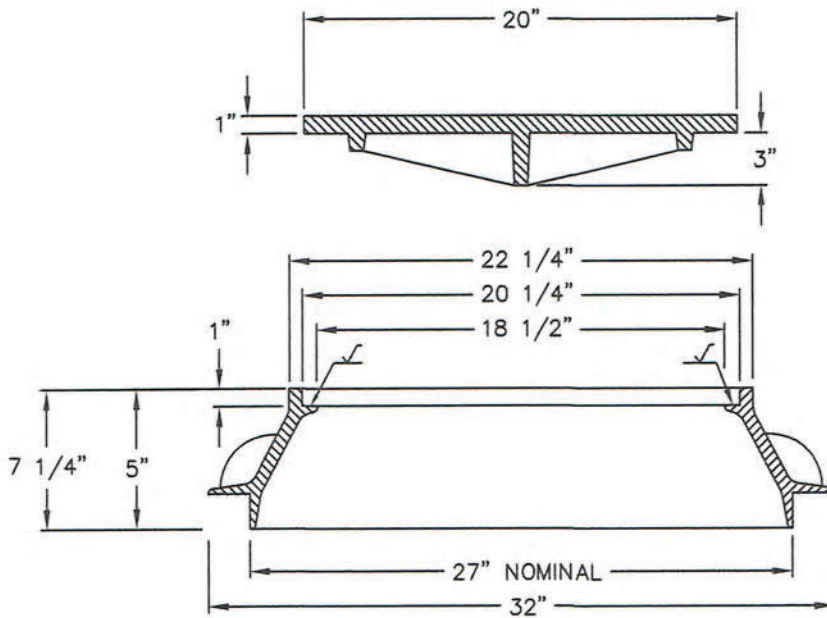
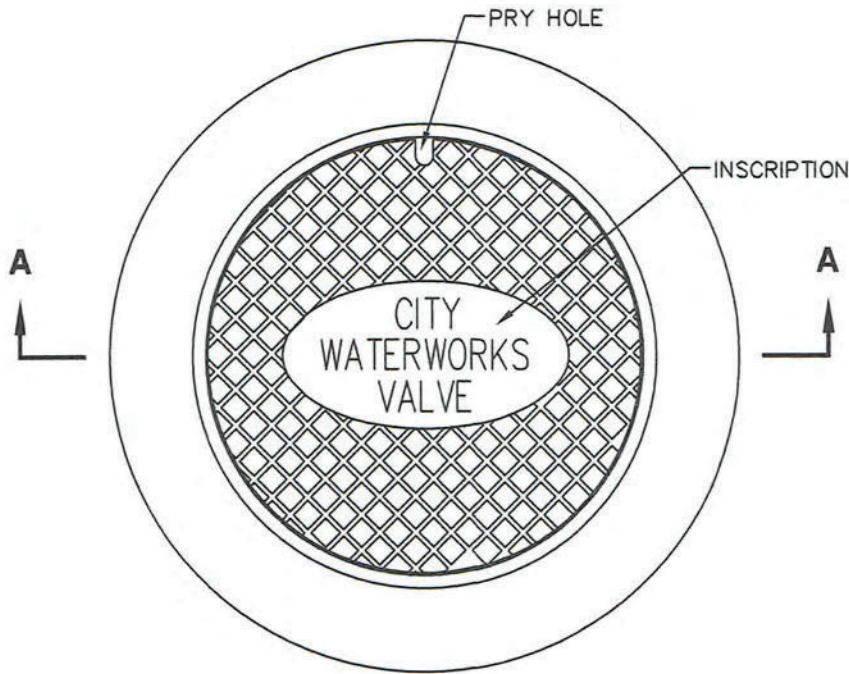

SECTION A-A

Nibley City Amendments:

1. Only allowed on 21" meter cans that house 1" meters.
2. Must be constructed with a 2" recessed hole to mount a meter antenna.
3. See the Nibley City Approved Materials List for information on specific product types and manufactures.

38" Frame and ~~double~~ cover

1. GENERAL

A. This frame and cover fits manholes in Plan 505.

2. PRODUCTS

A. Castings: Grey iron class 35 minimum, ASTM A48, coated with asphalt based paint or better (except on machined surfaces).

1) Cast the heat number on the frame and cover.

2) Give the frame and cover a machine finish so the cover will not rock.

3) √ designates machined surface.

4) Cast the name of the agency or its acronym as the first line. Cast the work "WATERWORKS" as the second line. Cast the word "Valve" (or applicable word) as the third line. Cast all letters on the cover in upper case flush with the surface finish.

3. EXECUTION (Not used)

Nibley City Amendments:

1. Only allowed on 36" meter cans that house 2" meters.

2. Must be constructed with a 2" recessed hole to mount a meter antenna.

3. See the Nibley City Approved Materials List for information on specific product types and manufactures.

Nibley City Amendments:

1. Only allowed on 36" meter cans that house 2" meters.
2. Must be constructed with a 2" recessed hole to mount a meter antenna.
3. See the Nibley City Approved Materials List for information on specific product types and manufactures.

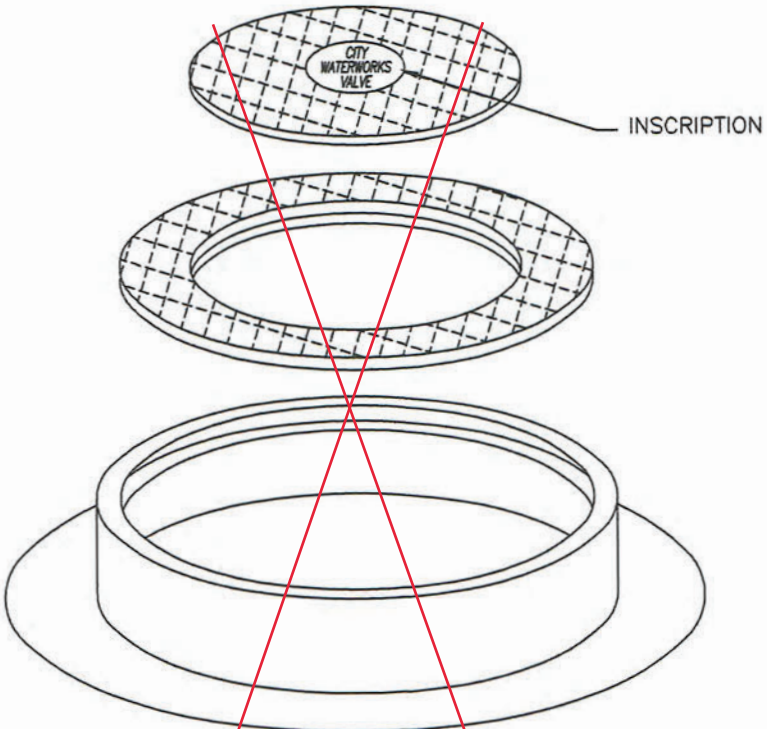

OBLIQUE

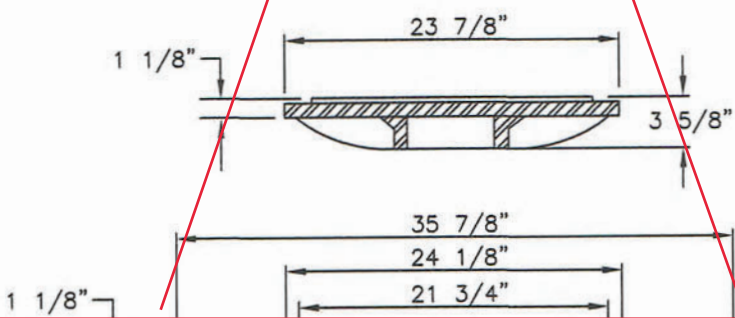

Change to a single piece lid 31 1/2" in diameter.
(Reference B-1800 Frame and Cover specifications)

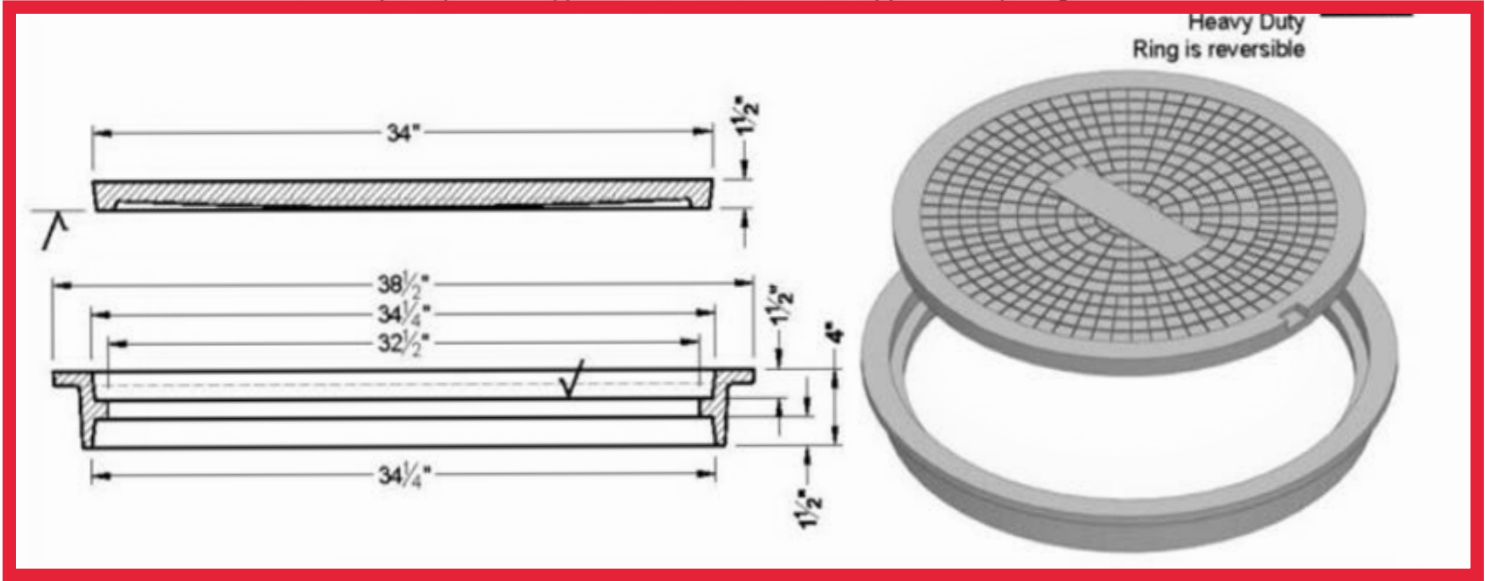

Fire hydrant with valve

1. GENERAL

- A. Before backfilling, secure inspection of installation by ENGINEER.
- B. Additional requirements are specified in APWA Section 33 11 00.

2. PRODUCTS

- A. Hydrant: Dry barrel, AWWA C502.
- B. Thrust Blocks: Concrete Class 4000, APWA Section 03 30 04.
- C. Reinforcement: Deformed, 60 ksi yield grade steel, ASTM A615. D.
- Backfill: APWA Section 31 05 13. **BORROW** Maximum particle size 3-inches.
 - 1) Sewer Rock: ASTM Size No. 3 (2" to 1") or larger.
 - 2) Other Type of Common Fill: CONTRACTOR's choice,.
- E. Geotextile: Stabilization-separation fabric, APWA Section 31 05 19.

3. EXECUTION

- A. Installation:
 - 1) Provide at least 1 cubic yard of sewer rock around drain hole at base of hydrant spool. Wrap geotextile around sewer rock and tape geotextile to hydrant spool to prevent silting of sewer rock.
 - 2) Paint fire hydrant to agency's fire hydrant paint code.
 - 3) Apply non-oxide grease to all buried metal surfaces. Wrap with polyethylene sheet and tape wrap.
 - 4) Notify fire department as soon as hydrant is placed in service.
- B. Thrust Blocks:
 - 1) Before pouring concrete, wrap pipe system with polyethylene sheet to prevent bonding of concrete to pipe system.
 - 2) Not required for flange or welded pipe systems.
- C. Backfill: Maximum lift thickness is 8-inches before compaction. Compaction is 95 percent or greater relative to a modified proctor density, APWA Section 31 23 26.

Nibley City Amendments:

- 1. Install tracer wire from the valve can to the hydrant with exposed wires inside the valve can and wrapped 3 times around the base of the hydrant.
- 2. See the Nibley City Approved Materials List for information on specific product types and manufactures.

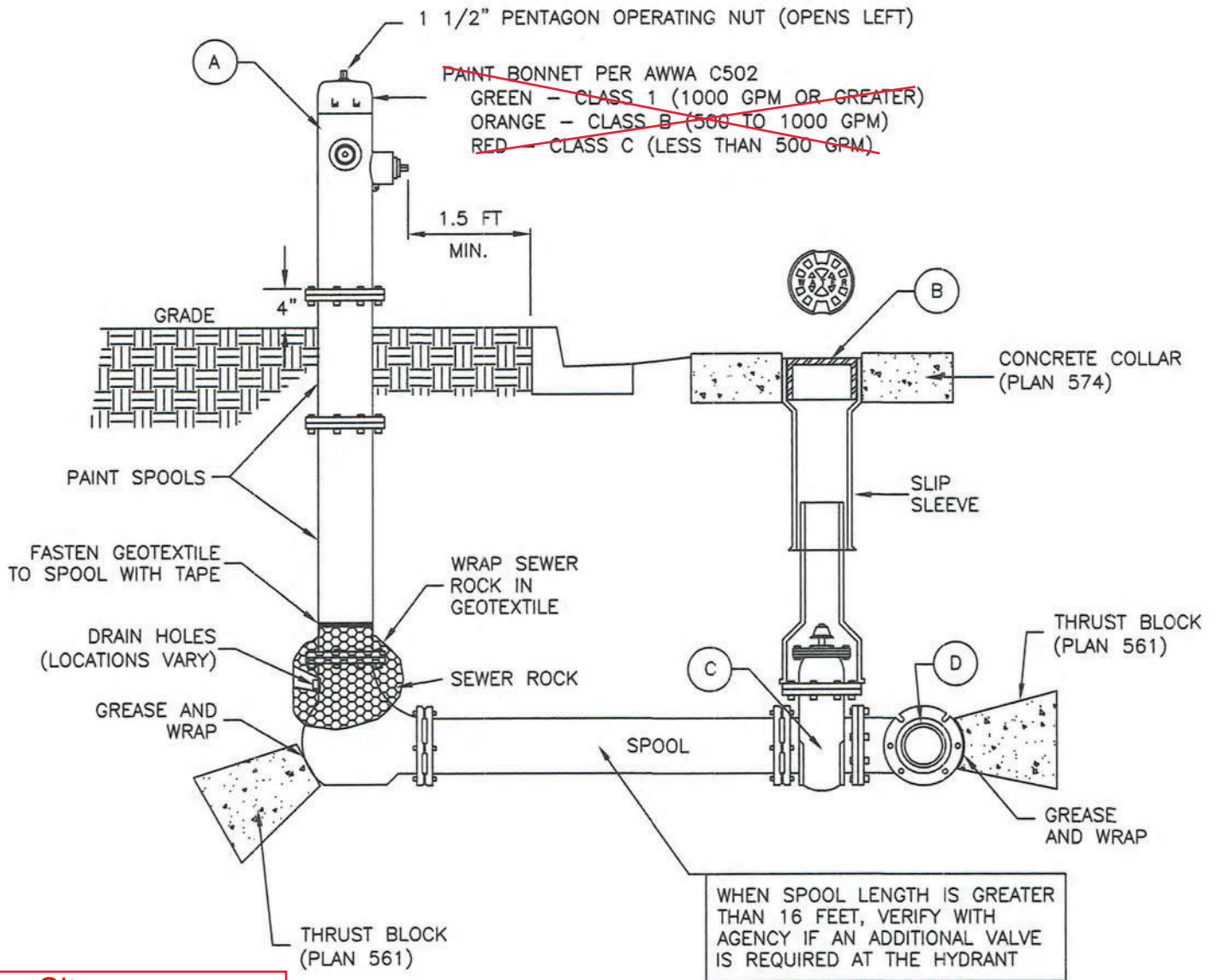

Nibley City Amendments:

1. Install tracer wire from the valve can to the hydrant with exposed wires inside the valve can and wrapped 3 times around the base of the hydrant.
2. See the Nibley City Approved Materials List for information on specific product types and manufactures.

LEGEND			
No.	*	ITEM	DESCRIPTION
(A)		FIRE HYDRANT	AWWA C502
(B)		VALVE BOX WITH LID	2-PIECE CAST IRON
(C)		GATE VALVE WITH 2" X 2" NUT	AWWA C509
(D)		TEE WITH 125 # FLANGE	AWWA C110

* FURNISHED BY UTILITY AGENCY

SECTION

1" METER AND BARREL

N.T.S.

1. METER PLACEMENT:
 - A. In new construction, install meter at front-center of lot.
 - B. All meters to be installed in the park strip or in PUE directly behind sidewalk if there is a swale or no parkstrip available
Water meters shall be located 5-feet from property lines at the corner of a lot.
 - C. Do not install meters **within** a driveway or approach, sidewalks, or curb and gutter.
2. METER BARREL: Set barrel so grade of the frame and cover matches the grade of the surrounding surface.
3. PIPE: C901 (Poly), blue in color, or 'K' Copper pipe required inside right-of-way.
4. INSPECTION: Before backfilling, secure installation inspection by ENGINEER.
5. BACKFILL: Provide and place per APWA Section 33 05 20. Compact per APWA Section 31 23 26 to a modified proctor density of 95 percent or greater. Maximum lift thickness is 8 inches before compaction. **Borrow- Maximum particle size 3-inches.**
6. CASTING: Grey iron class 35 minimum per ASTM A48.
7. Install 3/4" pipe (single pipe) through hole in the bottom of setter at least 18" long to stabilize setter.

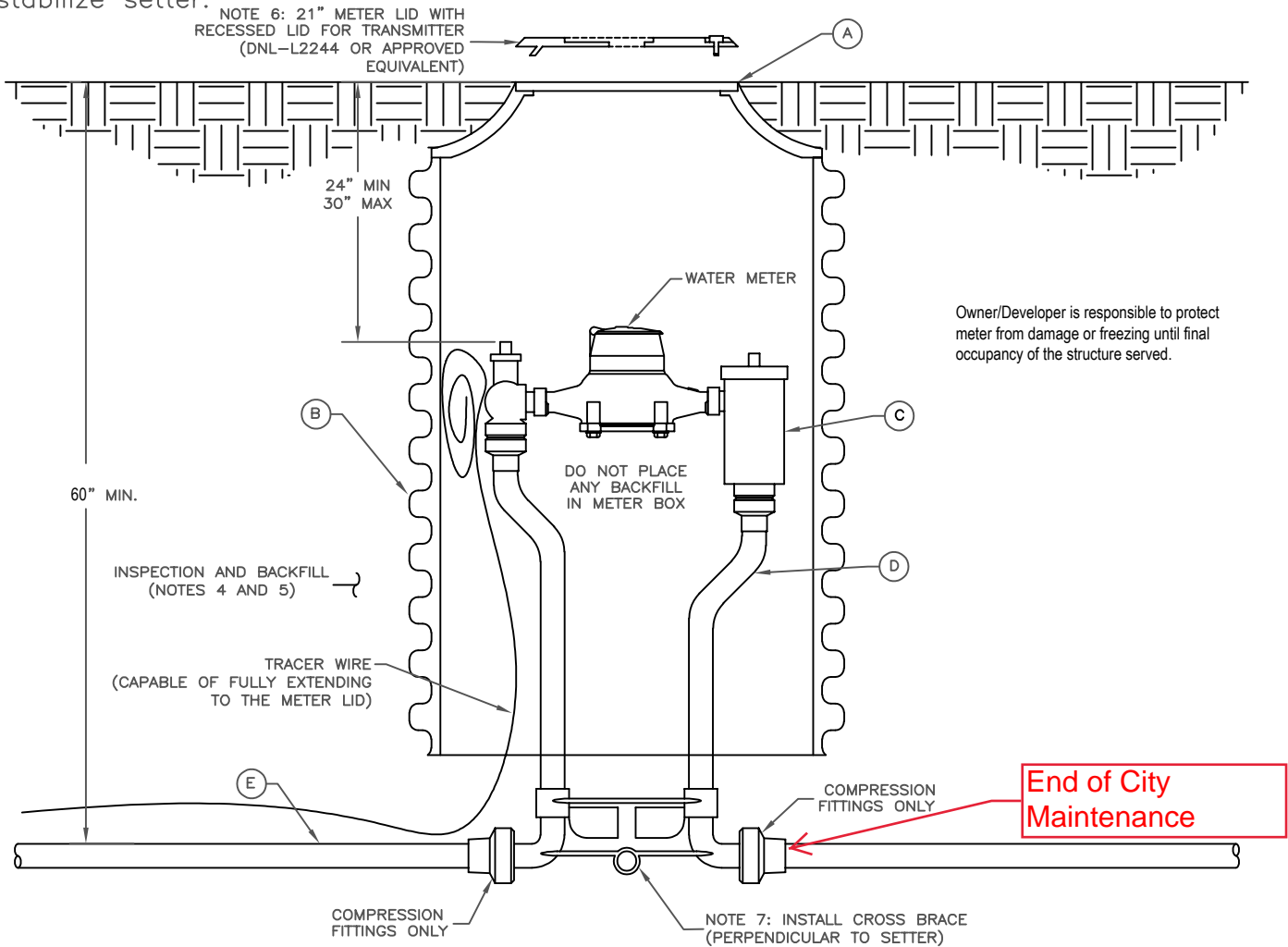

LEGEND

No.	ITEM	DESCRIPTION
(A)	FRAME AND COVER	CAST IRON COVER (GRASS/PARKSTRIP)
(B)	PLASTIC METER BARREL	ADS 21" X 48"
(C)	DOUBLE CHECK VALVE	1" FULL PORT WITH DOUBLE CHECK DEVICE
(D)	1" METER SETTER	1" COMPRESSION SETTER
(E)	POLY PIPE & STIFFENER	POLY PIPE (STAINLESS STEEL STIFFENER FOR COMPRESSION FITTINGS)

<p>NIBLEY CITY WATER DIVISION</p>	<p>1" METER AND BARREL</p>	DESIGNED: D. HOLMSTEAD	DATE: 2/1/2023	REVISION BLOCK:	<p>SCALE</p> <p>N.T.S.</p>	<p>SHEET NO:</p> <p>521S.1</p>
		DRAFTED: T. GLOVER	ENG #:			
		CHECKED: T. DICKINSON				

~~1 1/2" and 2" meter~~

1. **GENERAL**

MAG

- A. ~~Turbine~~ meters are required on all systems used exclusively for irrigation or fire protection.
- B. Where domestic use is applicable, use a standard meter.
- C. Before backfilling, secure inspection of installation by ENGINEER.

2. **PRODUCTS**

- A. Base Course: Untreated base course, APWA Section 32 11 23. Do not use gravel as a base course without ENGINEER's permission.
- B. Backfill: Common fill, APWA Section 31 05 13. **BORROW** Maximum particle size 3-inches.
- C. Castings: Grey iron class 35 minimum per ASTM A48, coated with asphalt based paint or better.

3. **EXECUTION**

A. Meter Placement:

- 1) All meters are to be installed in the ~~park strip or within 7 feet of the property line (street side).~~
- 2) Do not install meters under driveway approaches, sidewalks, or curb and gutter.
- 3) In new construction, install meter at ~~center of lot or per agency requirements.~~

in the Parkstrip. Locate in PUE directly behind sidewalk if there is a swale or no parkstrip available. Meter shall be installed at the corner of a lot 5-feet from property line.

B. Meter Box: Set box so grade of the frame and cover matches the grade of the surrounding surface.

C. Bypass Valve: Lock in off position.

~~D. Blocking: Use clay brick or concrete block.~~

~~E. Concrete Box:~~

- 1) Center frame and cover over water meter.
- 2) Allow 1-inch clearance around waterline where water line passes through ~~concrete box~~ wall. Seal opening with compressible seal.

Meter Barrel: 36" corrugated HDPE, PVC, or other as approved.

F. Pipe Outside of Right-of-Way: Coordinate with utility agency or adjacent property owner for type of pipe to be used outside of right-of-way.

G. Base Course and Backfill Placement: Maximum lift thickness before compaction is 8-inches. Compaction is 95 percent or greater relative to a modified proctor density, APWA Section 31 23 26.

Nibley City Amendments:

- 1. Install tracer wire from the main to the meter with exposed wire inside the meter can and connected to the tracer wire running along the main.
- 2. See the Nibley City Approved Materials List (APL) for information on specific product types and manufactures.

Install two 18-inch long 1" diameter PVC stabilizer pipes.

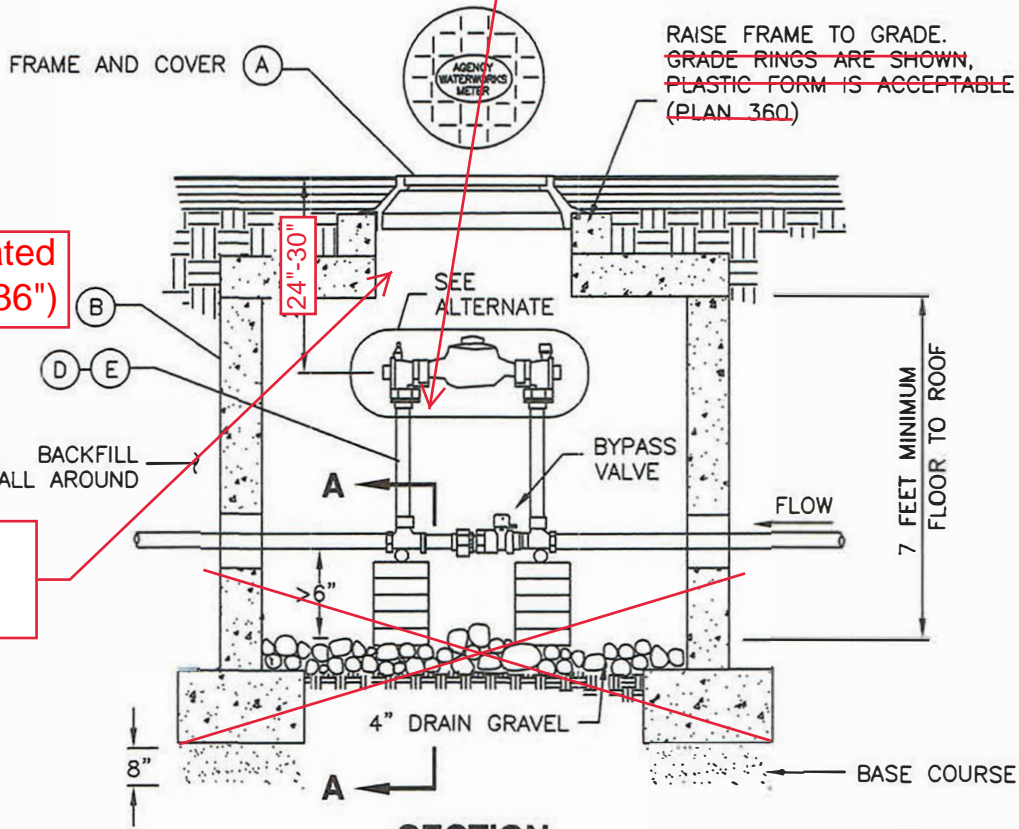

Corrugated Barrel (36")

Extend tracer wire to top of meter barrel.

RAISE FRAME TO GRADE. GRADE RINGS ARE SHOWN, PLASTIC FORM IS ACCEPTABLE (PLAN 360)

SECTION

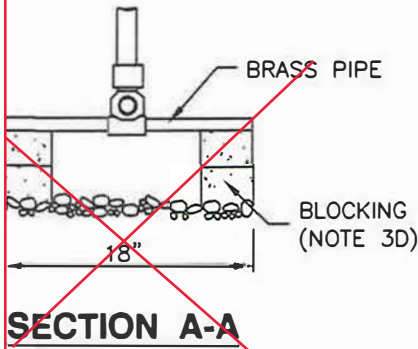

SECTION A-A

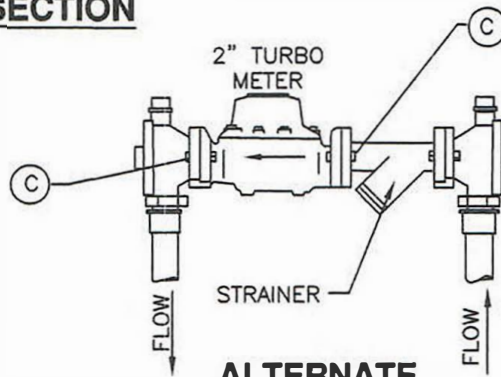

ALTERNATE TURBO METER INSTALLATION (NOTE 1A)

LEGEND

No.	*	ITEM	DESCRIPTION
(A)		22" FRAME AND COVER 38"	PLAN 502- 503
(B)		HDPE BARREL- 36" X 48"	
(C)		STAINLESS STEEL METER BOLTS	5/8" x 2 3/4" BRASS
(D)		1 1/2" CUSTOM SETTER WITH BYPASS	
(E)		2" CUSTOM SETTER WITH BYPASS	

* FURNISHED BY UTILITY AGENCY

Nibley City Amendments:
 1. Install tracer wire from the main to the meter with exposed wire inside the meter can and connected to the tracer wire running along the main.
 2. See the Nibley City Approved Materials List (APL) for information on specific product types and manufactures.

4" ULTRASONIC METER WITH 4" BYPASS

1. GENERAL

- A. Configuration may be changed at ENGINEER's discretion.
- B. Additional requirements are specified in APWA Section 33 12 16.

2. PRODUCTS

- A. Pipe Stand: Use adjustable pipe stand. Place stand on 12 inch x 12 inch by 2 inch concrete paver.
- B. Drain Gravel: Sewer rock, ASTM siz no. 3 (2" to 1") or equal, APWA Section 31 05 13.

3. EXECUTION

- A. Control Valve: Install valve with valve box adjacent to main.
- B. Center frame and cover over water meter.
- C. Allow 1-inch clearance around water line where water line passes through concrete box wall. Seal opening with compressible seal.
- D. Tracer Wire: Leave sufficient spool of wire to be pulled through vault and out lid to 3' above finished grade.

Nibley City Amendments:

- 1. Install tracer wire from the main to the meter with exposed wire inside the meter can and connected to the tracer wire running along the main.
- 2. Union connections are not allowed.
- 3. See the Nibley City Approved Materials List (APL) for information on specific product types and manufactures.

	NIBLEY CITY WATER DIVISION	4" ULTRASONIC METER AND BYPASS	DESIGNED: DMH	DATE: 02/10/2023	REVISION BLOCK: _____ _____ _____	SCALE N.T.S.	SHEET NO: 523S.2
		DRAFTED: DMH	ENG #:				
		CHECKED: TDICKINSON					

4" ULTRASONIC METER WITH 4" BYPASS

N.T.S.

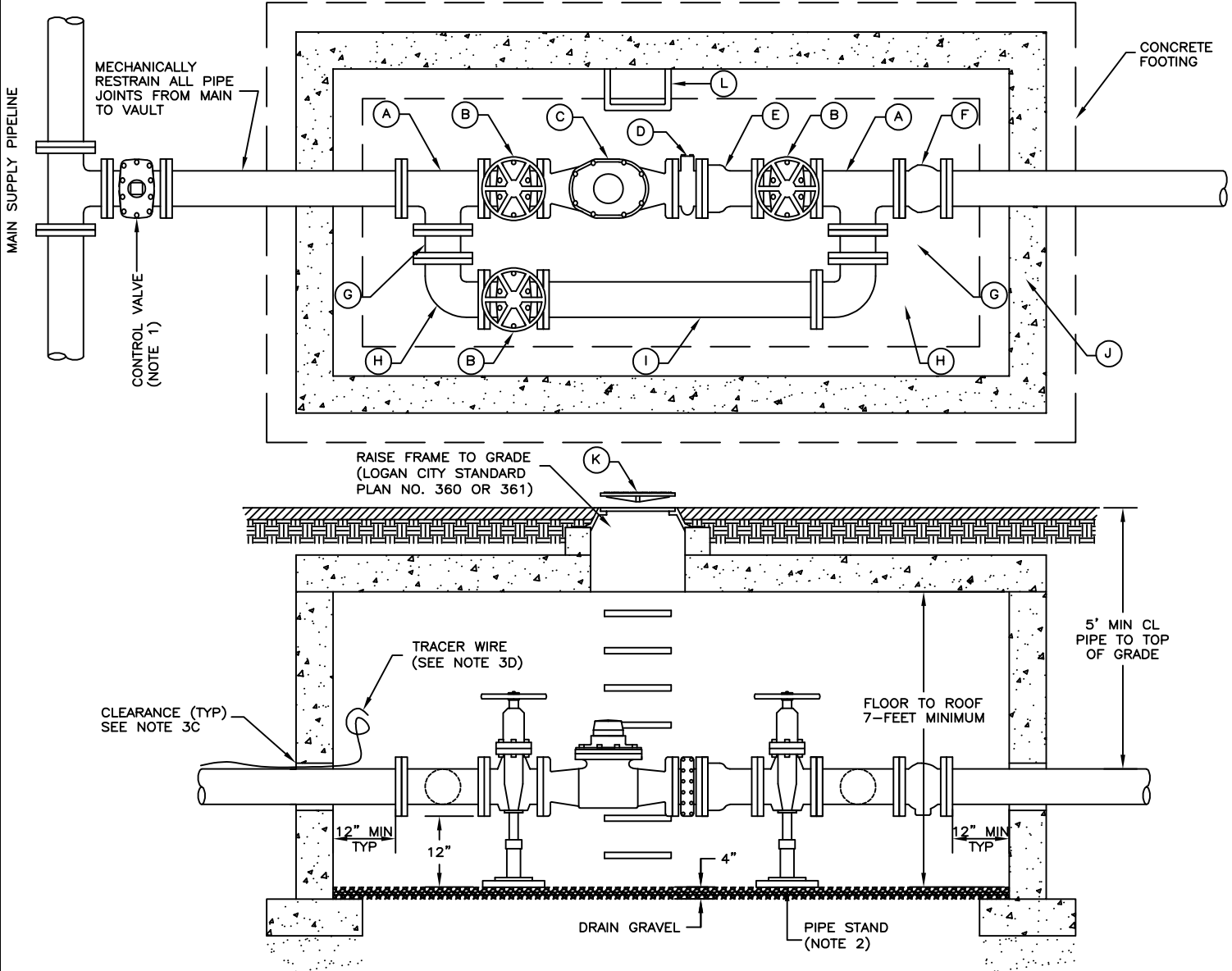

LEGEND

No.	ITEM	DESCRIPTION
(A)	4" FLANGE TEE FLG X FLG X FLG	
(B)	4" GATE VALVE W/ HAND WHEEL FLG X FLG	AWWA STANDARD C509
(C)	4" ULTRASONIC METER (14" LAY LENGTH)	NEPTUNE MACH 10 OR MASTER METER OCTAV
(D)	4" STRAINER	INSTALL ACCESS PLATE ON SIDE
(E)	4" FLG X MJ ADAPTER W/ 4" FLG X PE SPOOL	
(F)	4" GLOBE STYLE CHECK VALVE	
(G)	4" FLG X FLG D.I. PIPE SPOOL (12" LENGTH)	
(H)	4" X 4" FLG X FLG ELBOW	
(I)	4" FLG X FLG D.I. PIPE SPOOL	
(J)	CONCRETE BOX	NIBLEY CITY STANDARD PLAN No. 505.S.2
(K)	38" FRAME & COVER	NIBLEY CITY STANDARD PLAN No. 503
(L)	STEPS AT 12" C.C.	

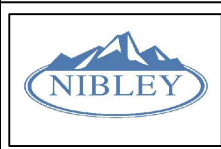

**NIBLEY CITY
WATER DIVISION**

**4" ULTRASONIC METER
AND BYPASS**

DESIGNED: DMH	DATE: 02/10/2023	REVISION BLOCK:
DRAFTED: DMH	ENG #:	
CHECKED: TDICKINSON		

SCALE
N.T.S.

SHEET NO:
523S.1

CONCRETE METER BOXES

N.T.S.

1. GENERAL

A. Before backfilling secure inspection of installation by ENGINEER.

2. PRODUCTS

A. Base Course: Untreated base course, APWA Section 32 11 23. Do not use gravel as a base course without ENGINEER's permission.

B. Backfill: Common fill, APWA Section 31 05 13. **BORROW** Maximum particle size 3 -inches.

C. Traffic Rated: H-20 load rated unless more stringent requirement is deemed necessary due to site conditions by Professional Engineer Licensed in the State of Utah.

3. EXECUTION

A. Base Course Placement: APWA Section 32 11 23. Maximum lift thickness is 8-inches before compaction. Compaction is 95 percent or greater relative to a modified proctor density, APWA Section 31 23 26.

B. Concrete Placement: APWA Section 03 30 10. Provide 1/2-inch radius edges. Apply a broom finish. Apply a curing agent.

C. Fill annular space around pipe wall penetrations with waterproof sealer.

D. Place frame and cover directly over valve or meter location.

E. Backfill: Provide backfill against the manhole shaft. Pea gravel and recycled RAP aggregate is NOT ALLOWED. Water jetting is NOT allowed. Maximum lift thickness is 8-inches before compaction. Compaction is 95 percent or greater relative to a standard proctor density, APWA Section 31 23 26.

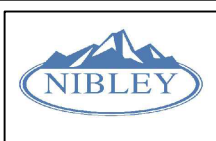

NIBLEY CITY
WATER DIVISION

CONCRETE METER
BOXES

DESIGNED:
DMH
DRAFTED:
DMH
CHECKED:
TDICKINSON

DATE:
02/10/2023
ENG #:

REVISION BLOCK:

SCALE
N.T.S.

SHEET NO:
505S.2

CONCRETE METER BOXES

N.T.S.

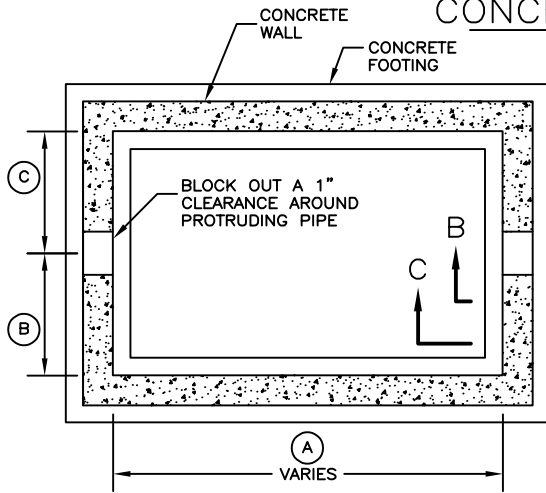

BOX PLAN

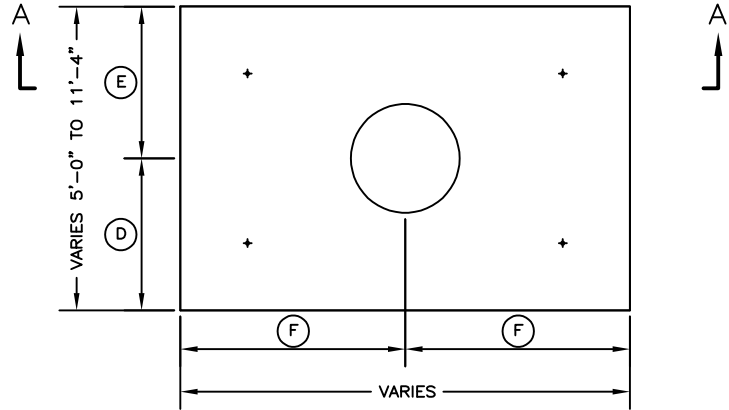

LID PLAN

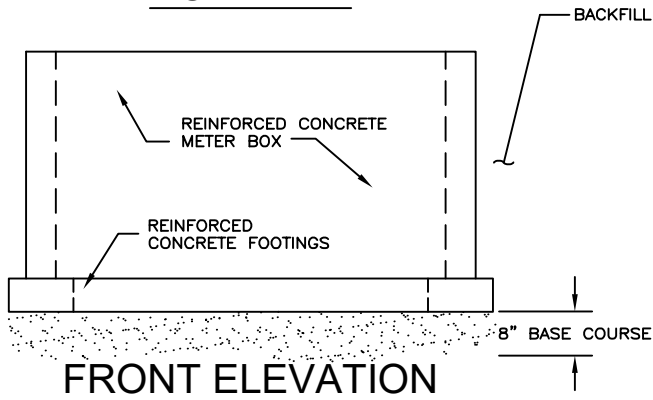

FRONT ELEVATION

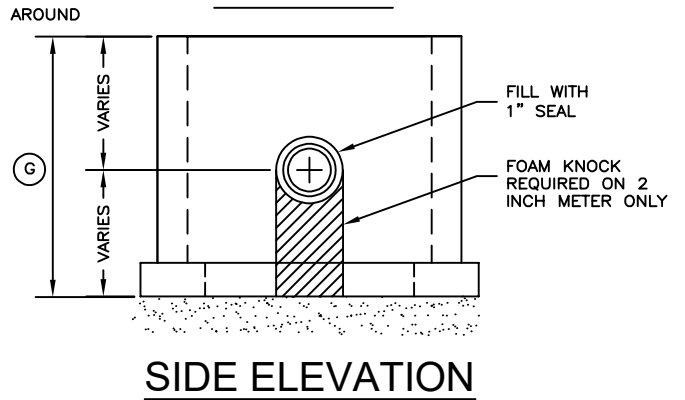

SIDE ELEVATION

TABLE OF DIMENSION

No.	METER SIZE			
	10"	8"	6"	4"
(A)	BY CUSTOM DESIGN APPROVED BY ENGINEER AND OWNER			9'-6"
(B)				3'-0"
(C)				2'-0"
(D)				3'-8"
(E)				2'-8"
(F)				4'-8"
(G)				9'-0"

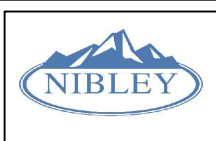

**NIBLEY CITY
WATER DIVISION**

**CONCRETE METER
BOXES**

DESIGNED: DMH
DRAFTED: DMH
CHECKED: TDICKINSON

DATE: 02/10/2023
ENG #:

REVISION BLOCK:

SCALE
N.T.S.

SHEET NO:
505S.1

Electrolysis monitoring station details

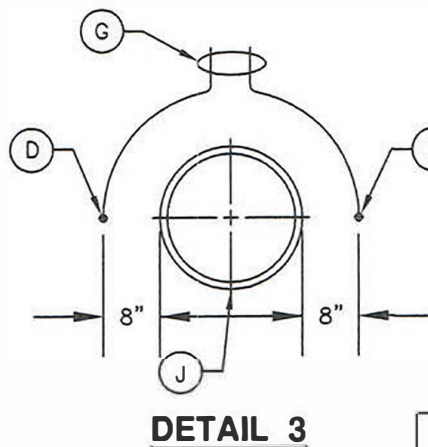
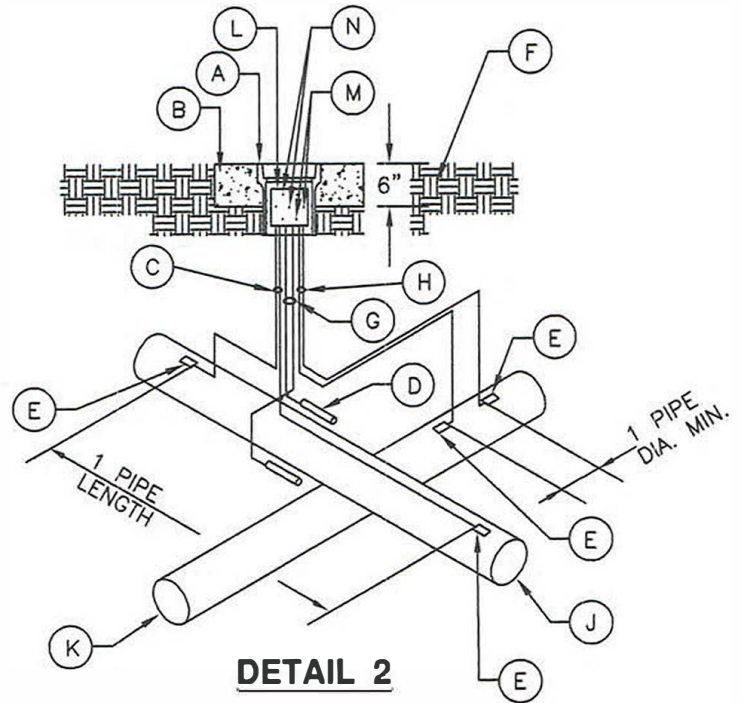
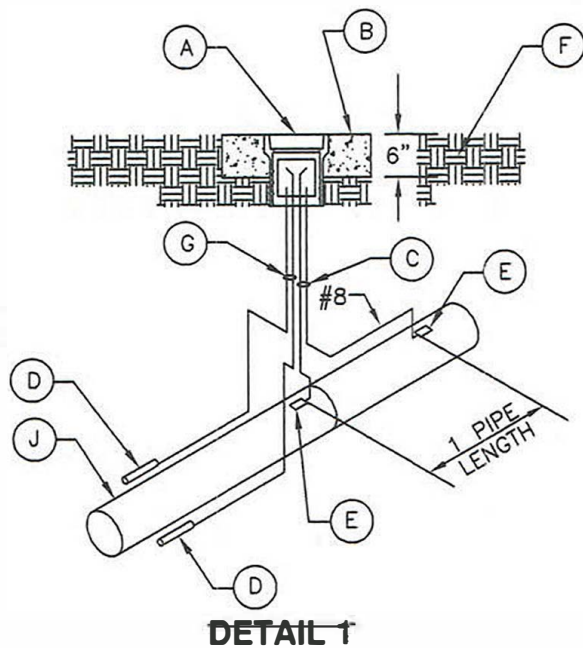

TYPICAL REFERENCE ELECTRODE 1/2" ROUND BY 9" ZINC WITH No. 12 STEEL WIRE CORE TO WHICH IS ATTACHED, BY A COMPRESSION FIT COPPER SLEEVE, A LENGTH OF PVC COATED No. 12 COPPER WIRE. THE SLEEVE JOINT IS WRAPPED WITH 2 MIL THICK PVC TAPE.

LEGEND	
No.	DESCRIPTION
(A)	FLUSH MOUNTED VALVE BOX AND LID
(B)	CONCRETE SLAB (6"x18"x18")
(C)	1-#8 & 1-#12 AWG COPPER WIRE WITH WHITE TW INSULATION
(D)	REFERENCE ELECTRODE
(E)	THERMITE WELD WIRE CONNECTION (TYPICAL)
(F)	EXISTING SOIL
(G)	2-#12 AWG COPPER WIRE WITH YELLOW TW INSULATION
(H)	1-#8 & 1-#12 AWG COPPER WIRE WITH BLUE TW INSULATION
(J)	NEW WATERMAIN
(K)	FOREIGN PIPELINE
(L)	PENSTOCK TERMINALS
(M)	FOREIGN PIPELINE TERMINALS
(N)	REFERENCE ELECTRODE AND ELECTRODE TERMINAL TERMINATED ON A PHEONOLIC PLATE

Water service line

1. GENERAL

A. Before backfilling, secure inspection of installation by ENGINEER.

2. PRODUCTS

A. Fittings: Provide brass fittings and nipples. Do not use galvanized materials. B.

Backfill: Common fill, APWA Section 31 05 13. **BORROW** Maximum particle size **3**-inches

3. EXECUTION

A. Backfill: Maximum lift thickness is 8-inches before compaction. Compaction is 95 percent or greater relative to a modified proctor density, APWA Section 31 23 26.

Nibley City Amendments:

1. Install tracer wire from the main to the meter with exposed wire inside the meter can and connected to the tracer wire running along the main.

2. Union connections are not allowed.

3. See the Nibley City Approved Materials List (APL) for information on specific product types and manufactures.

Nibley City Amendments:

1. Install tracer wire from the main to the meter with exposed wire inside the meter can and connected to the tracer wire running along the main.
2. Service lines shall be one continuous piece (couplers of any kind are not allowed).
3. See the Nibley City Approved Materials List (APL) for information on specific product types and manufactures.

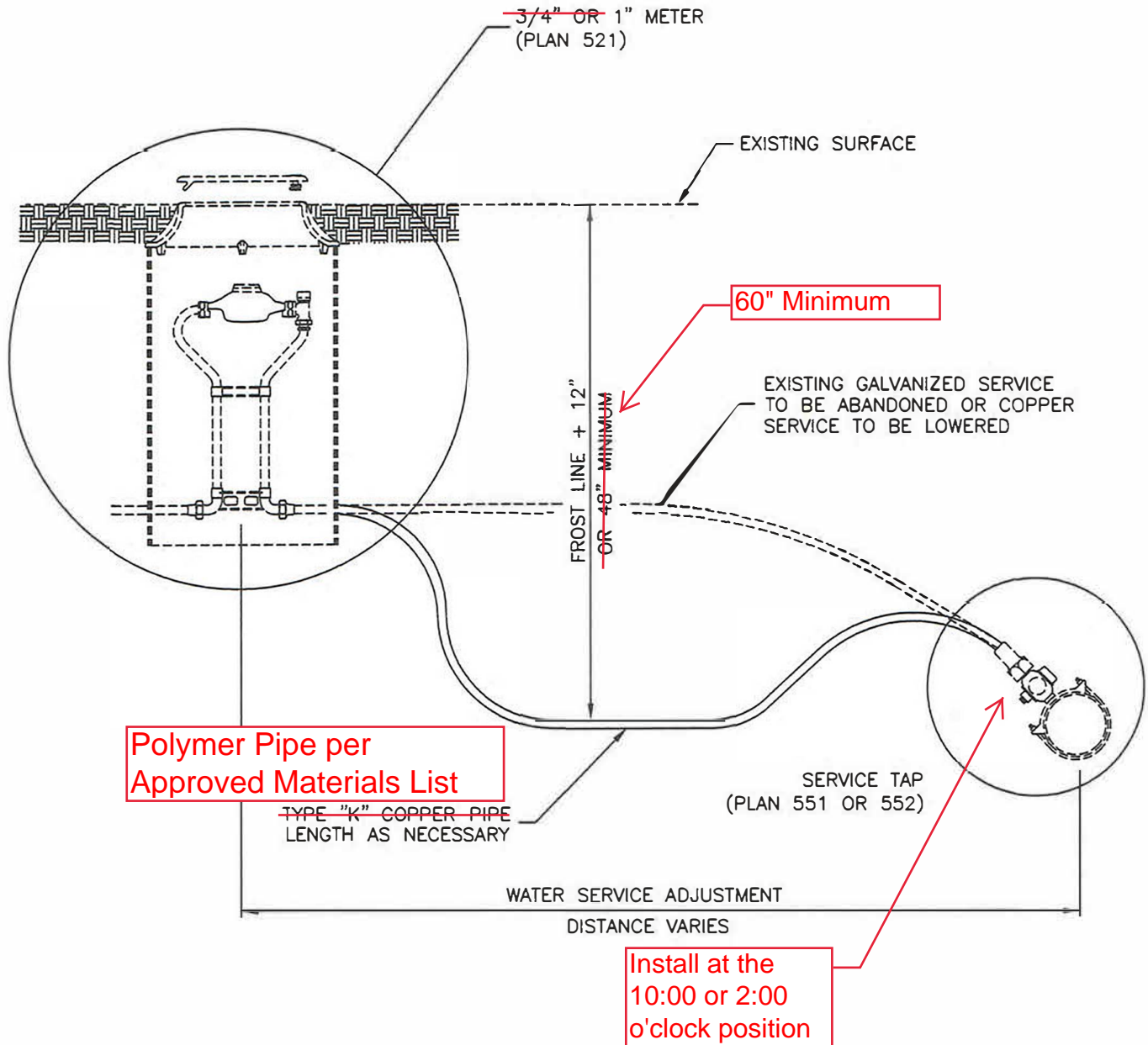

Water service line loop

1. GENERAL

A. Before backfilling, secure inspection of installation by ENGINEER.

2. PRODUCTS

- A. Base Course: Untreated base course, APWA Section 32 11 23. Do not use gravel as a base course without ENGINEER's permission.
- B. Piping: Match existing pipe, fittings, coupling sizes and materials.
- C. ~~Thrust Blocks: Concrete Class 4000, APWA Section 03 30 04.~~
- D. Reinforcement: Deformed, 60 ksi yield grade steel, ASTM A615.
- E. Backfill: Common fill, APWA Section 31 05 13. **BORROW** Maximum particle size **3**-inches.
- F. Grease: Non-oxide poly-FM.

3. EXECUTION

- A. ~~Thrust Blocks: Not required for flange or welded pipe systems. Before pouring thrust block concrete, wrap pipe system with plastic sheet to prevent bonding of concrete to pipe system.~~
- B. ~~Fittings: Use copper to copper flare fittings or copper to iron pack joint coupling with locking split clamp on iron pipe side and flare on copper side. All couplings to be brass.~~
- C. ~~Grease: Apply grease to all buried metal surfaces. Wrap with polyethylene sheet and tape wrap.~~
- D. ~~Steel Spool: Weld in place and provide slip on flange except when fitting in pipe system could move. Epoxy line per AWWA C210, C213, and coated per AWWA C208, or C214.~~
- E. Location: Loop water mains over top of sewer lines.
- F. Base Course and Backfill Placement: Maximum lift thickness is 8-inches before compaction. Compaction is 95 percent or greater relative to a modified proctor density, APWA Section 31 23 26.

Nibley City Amendments:

- 1. Install tracer wire along the main and services.**
- 2. See the Nibley City Approved Materials List (APL) for information on specific product types and manufactures.**

Nibley City Amendments:

1. Install tracer wire along the main and services.
2. See the Nibley City Approved Materials List (APL) for information on specific product types and manufactures.

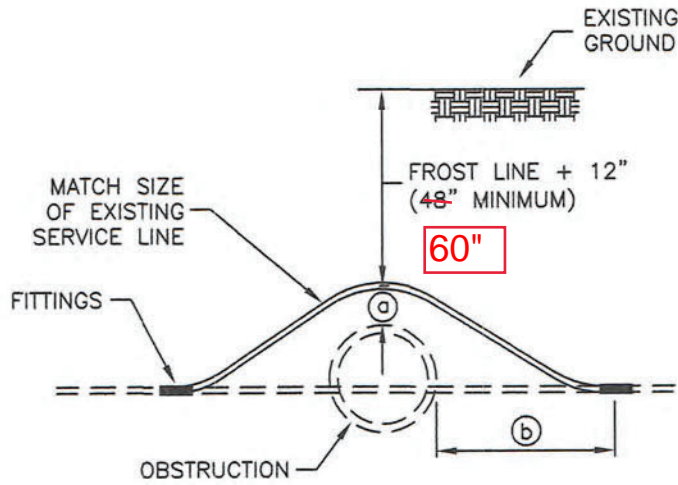

STYLE A

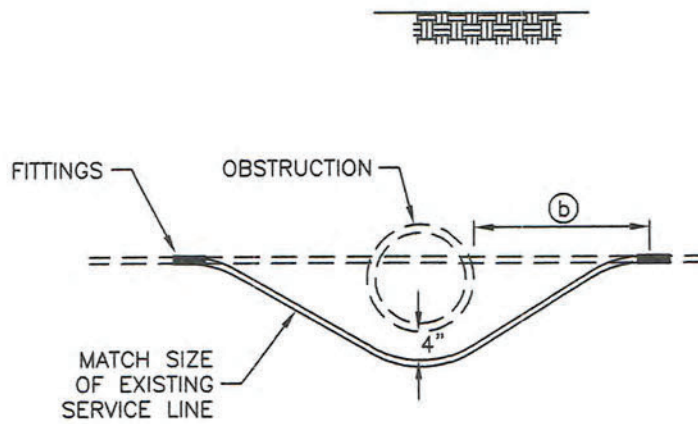

STYLE B

TABLE OF DIMENSIONS		
	OBSTRUCTION	
	SEWER MAIN	OTHER
ⓐ	18"	12" MIN.
ⓑ	10'-0"	12" MIN.

Water main line loop

1. GENERAL

A. Before backfilling, secure inspection of installation by ENGINEER.

2. PRODUCTS

A. Base Course: Untreated base course, APWA Section 32 11 23. Do not use gravel as a base course without ENGINEER's permission.

B. Piping: Match existing pipe, fittings, coupling sizes and materials.

C. Thrust Blocks: Concrete Class 4000, APWA Section 03 30 04.

D. Reinforcement: Deformed, 60 ksi yield grade steel, ASTM A615.

E. Backfill: Common fill, APWA Section 31 05 13. **(BORROW- 3-inch minus)**

Maximum particle size **3**-inches. F. Grease: Non-oxide poly-FM.

G. Couplings: Brass.

H. Mechanical Joint Restraints: Mechanical Joint Restraints to supplement Thrust Blocks

3. EXECUTION

A. Thrust Blocks: Not required for flanged or welded pipe systems. Before pouring thrust block concrete, wrap pipe system in plastic sheet to prevent bonding of concrete to pipe system.

~~B. Fittings: Use copper to copper flare fittings or copper to iron pack joint coupling with locking split clamp on iron pipe side and flare on copper side.~~

~~C. Grease: Apply grease to all buried metal surfaces. Wrap with polyethylene sheet and tape wrap.~~

~~D. Steel Spool: Weld in place and provide slip on flange except when fitting in pipe system could move. Epoxy line per AWWA C210, C213, and coated per AWWA C208, or C214.~~

E. Location: Loop water mains over top of sewer lines.

F. Base Course and Backfill Placement: Maximum lift thickness is 8-inches before compaction. Compaction is 95 percent or greater relative to a modified proctor density, APWA Section 31 23 26.

G. Mechanical Joint Restraints to supplement Thrust Blocks installed in accordance with Manufacturer's Installation requirements at locations as determined by Design Engineer

Nibley City Amendments:

1. Install tracer wire along the main and services.

2. When installing new water line, pipe deflection shall be the primary method of achieving the separation standards identified.

3. When deflection is not an option, use mechanical restraints with lengths per the detail provided in the written portion of chapter 5.

4. Connect fittings with continuous stainless steel rods.

5. See the Nibley City Approved Materials List (APL) for information on specific product types and manufactures.

STYLE A

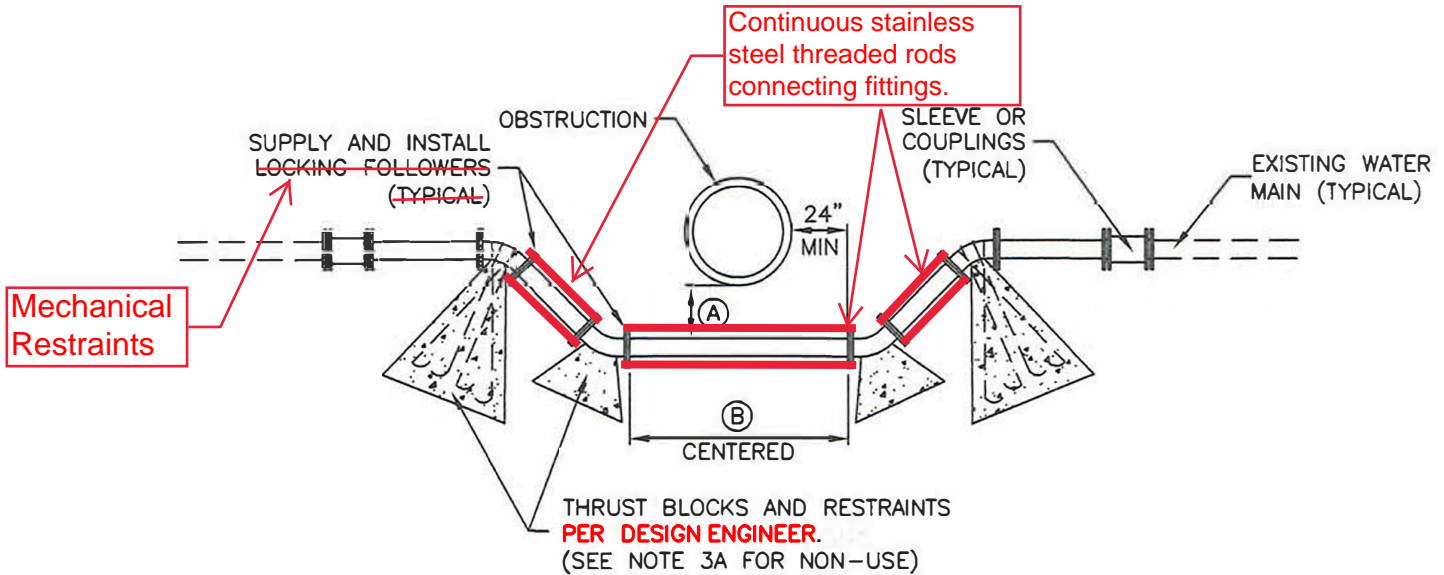

OBSTRUCTION	(A)	(B)
SEWER	18" MIN	20' MIN
OTHER	12" MIN	O.D. + 48"

Nibley City Amendments:

1. Install tracer wire along the main and services.
2. When installing new water line, pipe deflection shall be the primary method of achieving the separation standards identified.
3. Supplement concrete thrust blocks with mechanical restraints with lengths as determined by Design Engineer.
4. Connect fittings with stainless steel rods.
5. See the Nibley City Approved Materials List (APL) for information on specific product types and manufactures.

Water main line loop

1. GENERAL

A. Before backfilling, secure inspection of installation by ENGINEER.

2. PRODUCTS

A. Base Course: Untreated base course, APWA Section 32 11 23. Do not use gravel as a base course without ENGINEER's permission.

B. Piping: Match existing pipe, fittings, coupling sizes and materials.

C. Thrust Blocks: Concrete Class 4000, APWA Section 03 30 04.

D. Reinforcement: Deformed, 60 ksi yield grade steel, ASTM A615.

E.

Backfill: Common fill, APWA Section 31 05 13. **BORROW** Maximum particle size **3**-inches

F. Grease: Non-oxide poly-FM.

3. EXECUTION

A. Thrust Blocks: Not required for flange or welded pipe systems. Before pouring thrust block concrete, wrap pipe system with plastic sheet to prevent bonding of concrete to pipe system.

B. Fittings: Use copper to copper flare fittings or copper to iron pack joint coupling with locking split clamp on iron pipe side and flare on copper side. All couplings to be brass.

C. Grease: Apply grease to all buried metal surfaces. Wrap with polyethylene sheet and tape wrap.

D. Steel Spool: Weld in place and provide slip on flange except when fitting in pipe system could move. Epoxy line per AWWA C210, C213, and coated per AWWA C208, or C214.

E. Location: Loop water mains over top of sewer lines.

F. Base Course and Backfill Placement: Maximum lift thickness is 8-inches before compaction. Compaction is 95 percent or greater relative to a modified proctor density, APWA Section 31 23 26.

STYLE B AND C

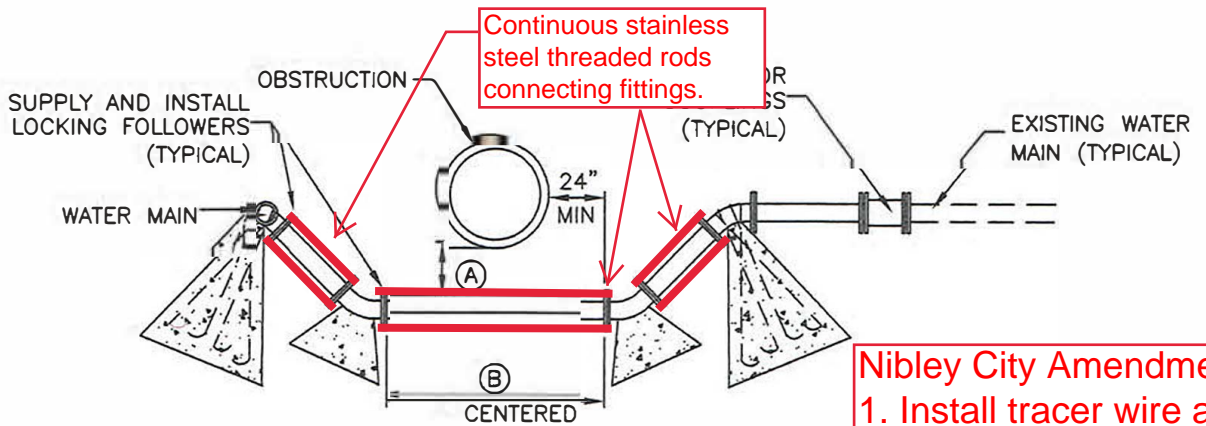

THRUST BLOCKS AND RESTRAINTS
PER DESIGN ENGINEER.
 (SEE NOTE 3A FOR NON-USE)

TABLE OF DIMENSIONS		
OBSTRUCTION	(A)	(B)
SEWER	18" MIN	20' MIN
OTHER	12" MIN	O.D. + 48"

STYLE B

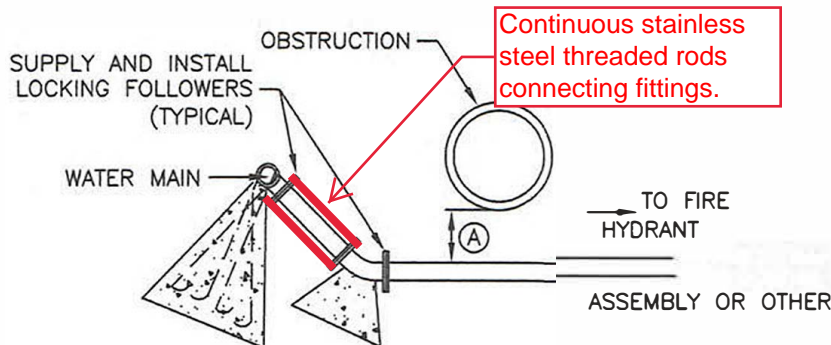

THRUST BLOCKS AND RESTRAINTS
PER DESIGN ENGINEER.
 (SEE NOTE 3A FOR NON-USE)

TABLE OF DIMENSIONS	
OBSTRUCTION	(A)
SEWER	18" MIN
OTHER	12" MIN

STYLE C

- Nibley City Amendments:**
1. Install tracer wire along the main and services.
 2. When installing new water line, pipe deflection shall be the primary method of achieving the separation standards identified.
 3. Supplement concrete thrust blocks with mechanical restraints with lengths as determined by Design Engineer.
 4. Connect fittings with stainless steel rods.
 5. See the Nibley City Approved Materials List (APL) for information on specific product types and manufactures.

Fire hydrant replacement or relocation

1. GENERAL

- A. Drawing is a single line diagram showing a minimum and typical connection.
- B. Additional water system requirements are specified in APWA Section 33 11 00.
- C. Before backfilling, secure inspection of installation by ENGINEER.

2. PRODUCTS

- A. Base Course: Untreated base course, APWA Section 32 11 23. Do not use gravel as a base course without ENGINEER's permission.
- B. Piping: Match existing pipe, fittings, coupling sizes and materials.
- C. Thrust Blocks:
 - 1) Temporary - Use wood.
 - 2) Permanent - Concrete Class 4000, APWA Section 03 30 04.
- D. Backfill: Common fill, APWA Section 31 05 13. **BORROW** Maximum particle size **3**-inches.
- E. Grease: Non-oxide poly-FM.

3. EXECUTION

- A. Hydrant: Adjust to grade with pipe spool if necessary.
 - 1) Provide at least 1 cubic yard of sewer rock, APWA Section 31 05 13 around drain hole at base of hydrant. Wrap plastic over sewer rock to prevent silting.
 - 2) Paint fire hydrant to agency's fire hydrant paint code.
 - 3) Apply grease to all buried metal surfaces. Wrap with polyethylene sheet and tape wrap.
 - 4) Notify fire department as soon as hydrant is placed in service.
- B. Connections: If existing valve and hydrant have O.B. connections, delete MJ x Flange adapter and install 6-inch MJ sleeve. Add a new valve at the tee connection.
- C. Valve Boxes. **Replace** any C.I.S.T. valve boxes **with new**. Adjust to grade as necessary on relocated hydrant.
- D. Thrust Blocks: Not required on flanged or welded pipe systems. Before pouring concrete, wrap pipe system plastic sheet to prevent bonding of concrete to pipe system.
- E. Backfill: Maximum lift thickness is 8-inches before compaction. Compaction is 95 percent or greater relative to a modified proctor density, APWA Section 31 23 26.
- F. Surface Restoration:
 - 1) Landscaped Surface: Rake to match existing grade. Replace vegetation to match pre-construction conditions. Follow APWA Section 32 92 00 (turf or grass) or APWA Section 32 93 13 (ground cover) requirements.
 - 2) Paved Surface: Do not install bituminous concrete or Portland cement concrete surfacing until trench compaction is acceptable to ENGINEER. Follow APWA Section 33 05 25 (bituminous concrete surfacing), or APWA Section 33 05 25 (concrete surfacing).

Nibley City Amendments:

- 1. Install tracer wire along the main and services.**
- 2. See the Nibley City Approved Materials List (APL) for information on specific product types and manufactures.**

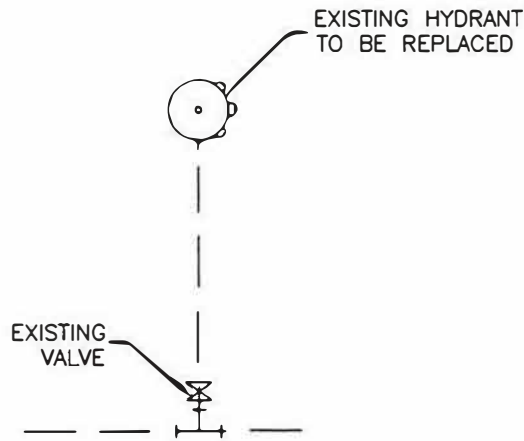

REPLACEMENT OF FIRE HYDRANT

Nibley City Amendments:
 1. Install tracer wire along the main and services.
 2. See the Nibley City Approved Materials List (APL) for information on specific product types and manufactures.

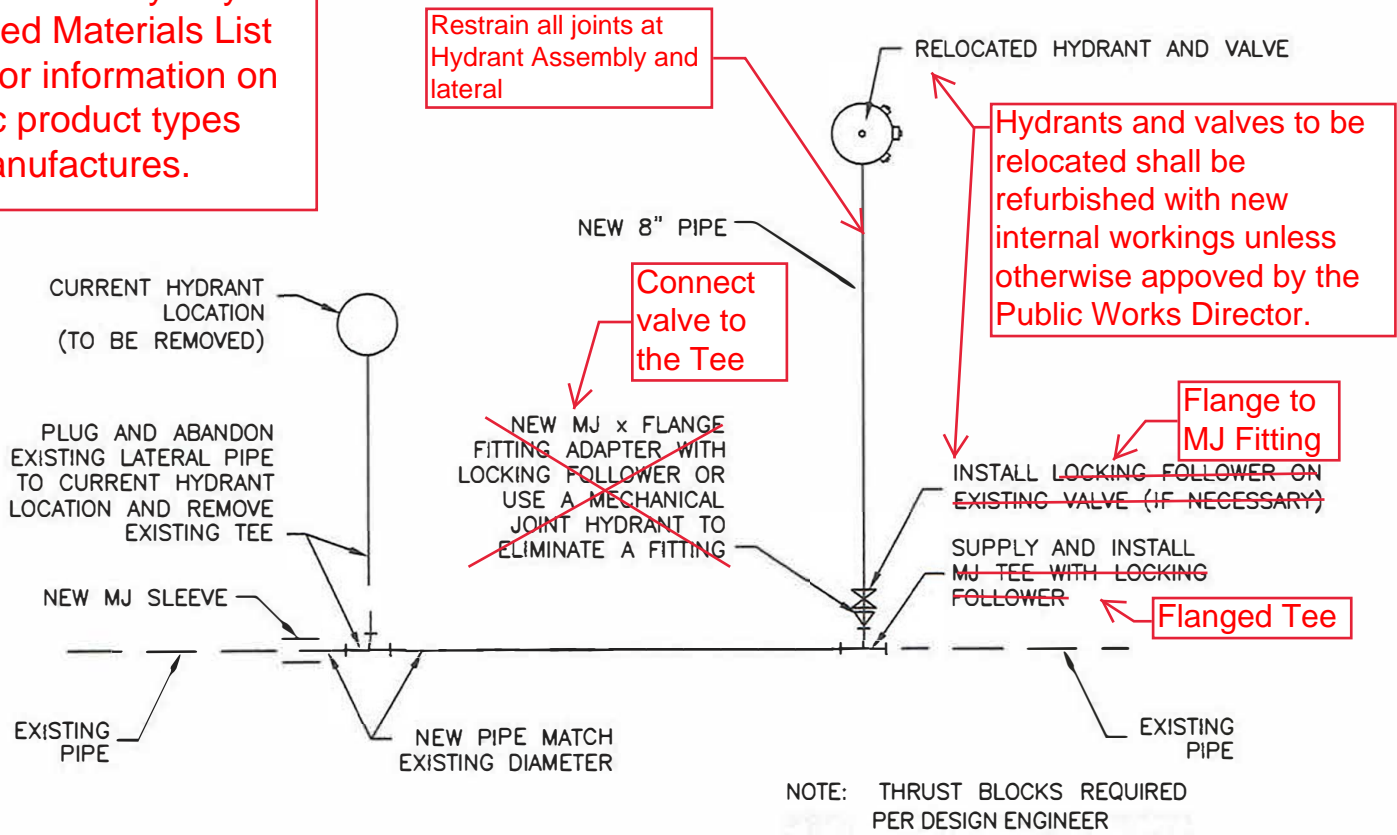

RELOCATION OF FIRE HYDRANT

1" & 2" SERVICE TAPS

1. TAPPING: Tapping on Nibley City mains to be performed by Nibley City crews only. Place taps a minimum of 24 inches apart. Use a tapping tool that is sized corresponding to the size of the service line to be installed. No taps within 24 inches of the end of pipe or from the shoulder of the bell of the pipe.
2. TAPE: Teflon tape is required on all taps.
3. INSPECTION: Prior to backfilling around taps, secure inspection of installation by ENGINEER.
4. BACKFILL: Provide and place per APWA Section 33 05 20 **BORROW- MAXIMUM PARTICLE SIZE 3-INCHES** Compact per APWA Section 31 23 26 to a modified proctor density of 95 percent or greater. Maximum lift thickness is 8 inches before compaction.
5. **TRACER: Install tracer wire along the main and services. See Nibley City Approved Materials List**

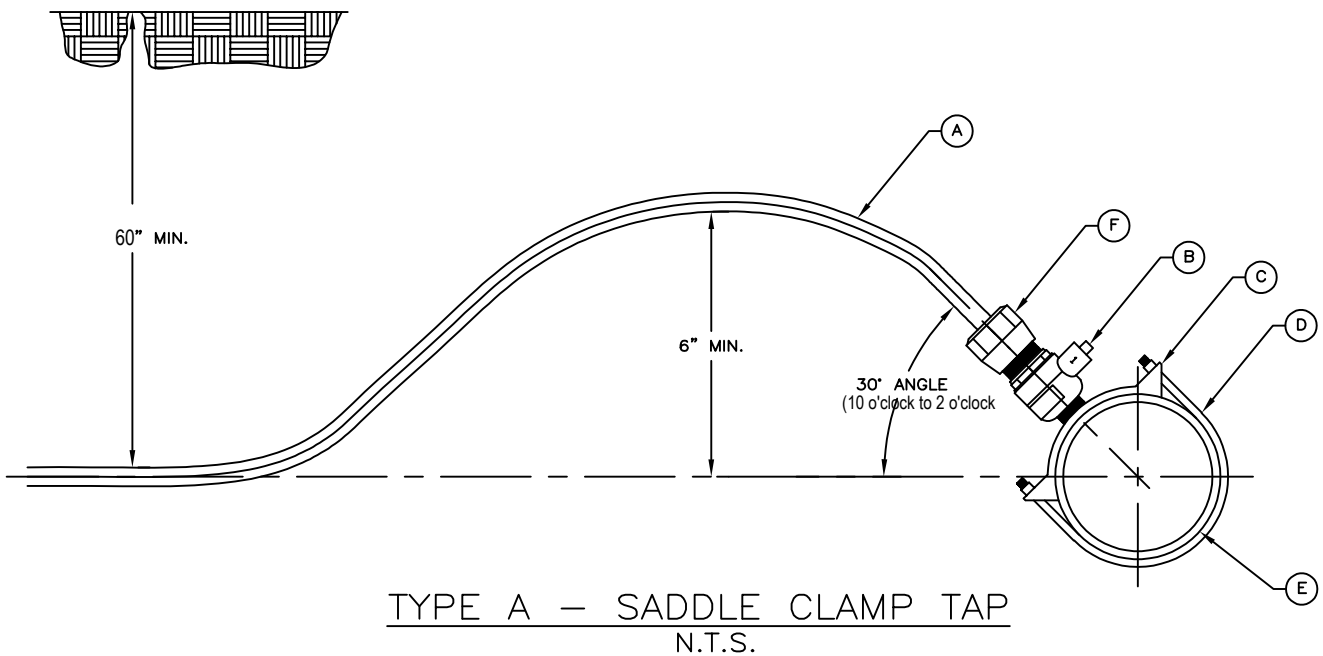

LEGEND

No.	ITEM	DESCRIPTION
(A)	POLY PIPE	POLYETHYLENE WATER SERVICE PIPE
(B)	CORPORATION STOP	BRASS (BALL TYPE)
(C)	SERVICE SADDLE CLAMP	STAINLESS STEEL, BRASS
(D)	SERVICE SADDLE STRAPS	STAINLESS STEEL
(E)	WATER MAIN PIPE	(D.I., C.I.C A.C., P.V.C.)
(F)	COMPRESSION FITTING (W/ STIFFENER)	FLARED FITTING NOT ALLOWED

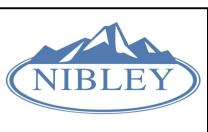

**NIBLEY CITY
WATER DIVISION**

1" & 2" TAP

DESIGNED: D. HOLMSTEAD	DATE: 2/1/2023	REVISION BLOCK:	SCALE	SHEET NO:
DRAFTED: T. GLOVER	ENG #:	_____	N.T.S.	551 S
CHECKED: T. DICKINSON		_____		

Direct bearing thrust block

1. GENERAL

- A. Thrust design for pipe sizes or configurations not shown require special design.
- B. Bearing areas, volumes, and special thrust blocking details shown on Drawings take precedence over this plan.
- C. Restraint sizing is based upon a maximum operating pressure of 150 psi and a test pressure of 200 psi, and a minimum soil bearing strength of 2,000 psf. Operating pressures in excess of 150 psi or soils with less than 2,000 pound bearing strength will require special design.
- D. Before backfilling around thrust block, secure inspection of installation by ENGINEER.

2. PRODUCTS

- A. Base Course: Untreated base course, APWA Section 32 11 23. Do not use gravel as a base course without ENGINEER's permission.
- B. Backfill: Common fill, APWA Section 31 05 13. **BORROW** Maximum particle size 3-inches.
- C. Thrust Blocks: Concrete Class 4000, APWA Section 03 30 04.
- D. Grease: Non-oxide poly-FM.

3. EXECUTION

- A. Pour concrete against undisturbed soil.
- B. Pipe Joints: Do not cover with concrete. Leave completely accessible.
- C. Grease: Apply grease to all buried metal surfaces. Wrap with polyethylene sheet and tape wrap.
- D. Locking restraint devices may be used in conjunction with concrete thrust blocking (at discretion of ENGINEER).
- E. Base Course and Backfill Placement: Maximum lift thickness is 8-inches before compaction. Compaction is 95 percent or greater relative to a modified proctor density, APWA Section 31 23 26.

- 1. Water Design Standards require mechanical joint restraints designed by the engineer of record and installed in accordance with manufacturer's installation instructions.
- 2. Where installation of mechanical joint restraints is not possible for new connections and/or for existing piping systems, the design engineer shall provide engineering calculations and details for construction of concrete thrust blocks.
- 3. APWA Plan 561 is strictly for reference and guidance for repairs and conditions where a design engineer is not available.

Nibley City Amendment:

- 1. Where the entire piping system is installed with engineer designed mechanical joint restraints, an additional 1.5 to 2.0 square foot concrete thrust block shall be provided.

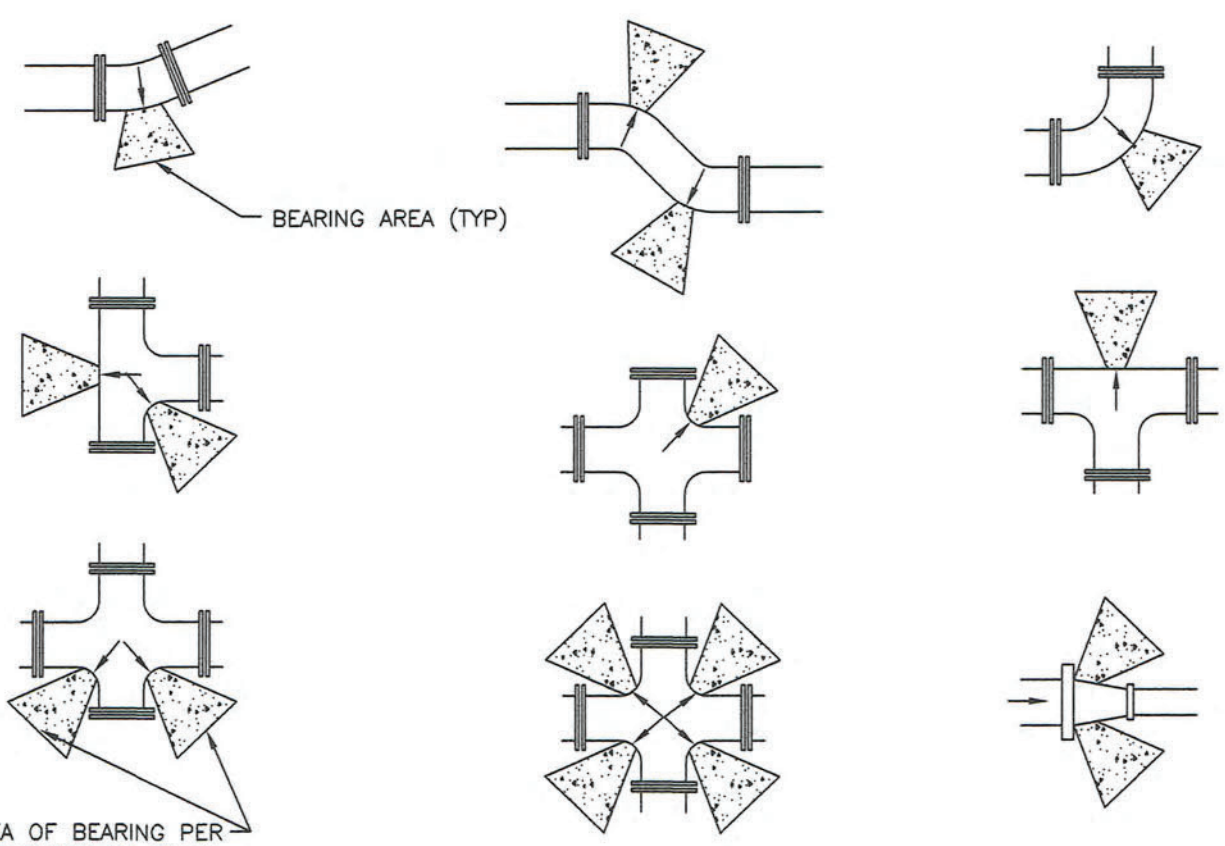

THE AREA OF BEARING PER THRUST BLOCK TO EQUAL 1/2 THE AREA SPECIFIED FOR THE LARGEST PIPE OR FITTING SIZE

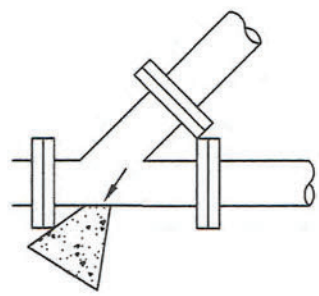

MINIMUM BEARING AREA IN SQ. FT.

SIZE OF PIPE	TEES, VALVES DEAD ENDS	90° BENDS	45° BENDS	22 1/2° BENDS	11 1/4° BENDS
4"	2	3	2	2	2
6"	4	5.5	3	2.5	2
8"	6.5	9.5	5	2.75	2.5
12"	14	20	11	5.5	3
14"	19	26.5	14.5	7.5	4
16"	24	34	18.5	9.5	6
20"	27	52	28.5	14.5	9
24"	53	74	41	21	12
30"	81	114	62	32	16

Nibley City Amendment:
 1. Where the entire piping system is installed with engineer designed mechanical joint restraints, an additional 1.5 to 2.0 square foot concrete thrust block shall be provided.

Tie-down thrust restraints

1. GENERAL

- A. Thrust design for pipe sizes or configurations not shown require special design.
- B. Bearing areas, volumes, and special thrust blocking details shown on Drawings take precedence over this plan.
- C. Restraint sizing is based upon a maximum operating pressure of 150 psi and a test pressure of 200 psi, and a minimum soil bearing strength of 2,000 psf. Operating pressures in excess of 150 psi or soils with less than 2,000 pound bearing strength will require special design.
- D. Before backfilling around thrust block, secure inspection of installation by ENGINEER.

2. PRODUCTS

- A. Base Course: Untreated base course, APWA Section 32 11 23. Do not use gravel as a base course without ENGINEER's permission.
- B. Backfill: Common fill, APWA Section 31 05 13. **BORROW** Maximum particle size 3-inches.
- C. Concrete: Class 4,000 minimum, APWA Section 03 30 04.
- D. Reinforcement: Deformed, steel, ASTM A615. Give bars an epoxy coating at least 15 mils thick. Minimum stress yield strength of steel tie-down bars is 70,000 ksi.
- E. Grease: Non-oxide poly-FM.

3. EXECUTION

- A. Pour concrete against undisturbed soil. Concrete must be allowed to cure in thrust restraints for 5 days before pressurizing water lines or have additional approved thrust restraints installed before pressurizing the water line.
- B. Pipe Joints: Do not cover with concrete. Leave completely accessible.
- C. Grease: Apply grease to all buried metal surfaces. Wrap with polyethylene sheet and tape wrap.
- D. Locking restraint devices may be used in conjunction with concrete thrust blocking (at discretion of ENGINEER).
- E. Base Course and Backfill Placement: Maximum lift thickness is 8-inches before compaction. Compaction is 95 percent or greater relative to a modified proctor density, APWA Section 31 23 26.

Nibley City Amendments:

- 1. Water Design Standards require mechanical joint restraints designed by the engineer of record and installed in accordance with manufacturer's installation instructions.
- 2. Where installation of mechanical joint restraints is not possible for connections and existing piping, the design engineer shall provide engineering calculations and details for construction of concrete tie-down thrust blocks.
- 3. APWA Plan 562 is strictly for reference and guidance for repairs and conditions where a design engineer is not available.

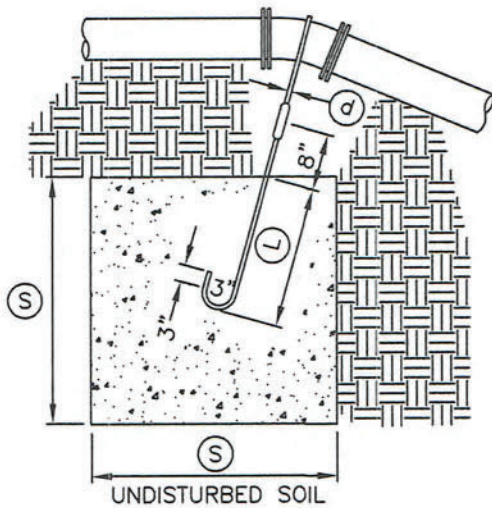

TYPE A RESTRAINT

FOR 11 1/4" - 22 1/2" VERTICAL BENDS

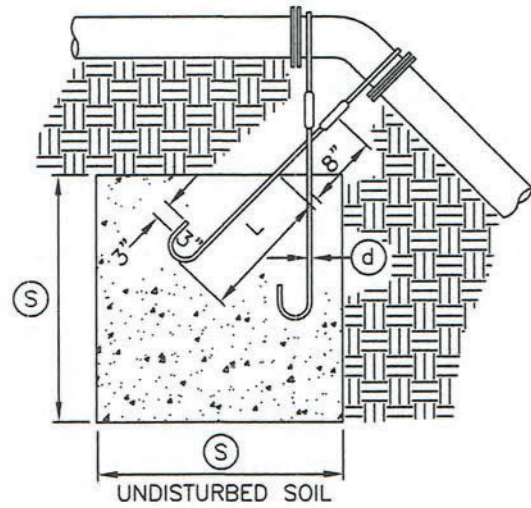

TYPE B RESTRAINT

FOR 45° VERTICAL BENDS

TABLE OF DIMENSIONS					
PIPE SIZE NOMINAL DIAMETER - INCH	VERTICAL BEND IN DEGREES	CONCRETE BLOCKING IN CUBIC FEET	(S) SIDE OF CUBE - FEET	(d) DIAMETER OF SHANK OR REBAR RODS - INCH	(L) DEPTH OF ROD CONCRETE - FEET
4"	11 1/4°	8	2.0	5/8"	1.5
	22 1/2°	15.6	2.5	5/8"	2.0
6"	11 1/4°	15.6	2.5	5/8"	2.0
	22 1/2°	34.3	3.25	5/8"	2.0
8"	11 1/4°	27	3.0	5/8"	2.0
	22 1/2°	64	4.0	5/8"	2.0
12"	11 1/4°	64	4.0	5/8"	2.0
	22 1/2°	125	5.0	3/4"	3.0
16"	11 1/4°	107	4.25	7/8"	3.0
	22 1/2°	216	6.0	7/8"	3.0
20"	11 1/4°	138	5.17	1"	3.5
	22 1/2°	334	6.94	1"	4.0
24"	11 1/4°	240	6.22	1"	4.0
	22 1/2°	476	7.81	1"	4.0
30"	11 1/4°	369	7.17	1"	4.0
	22 1/2°	733	9.02	1"	4.0

TABLE OF DIMENSIONS					
PIPE SIZE NOMINAL DIAMETER - INCH	VERTICAL BEND IN DEGREES	CONCRETE BLOCKING IN CUBIC FEET	(S) SIDE OF CUBE - FEET	(d) DIAMETER OF SHANK OR REBAR RODS - INCH	(L) DEPTH OF ROD CONCRETE - FEET
4"	45°	1	3.0	5/8"	2.0
				5/8"	
6"		2.37	4.0	5/8"	2.5
				5/8"	
8"		3.97	4.75	5/8"	3.0
				5/8"	
12"		9.04	6.25	5/8"	4.0
				5/8"	
16"		17.24	7.75	3/4"	4.0
				3/4"	
20"		26.52	9.217	3/4"	4.0
				3/4"	
24"		37.82	10.07	3/4"	4.0
				3/4"	
30"		58.26	11.63	3/4"	4.0
				3/4"	

4" washout valve

1. GENERAL

- A. Before backfilling, secure inspection of installation by ENGINEER.
- B. Water mains 12-inches and larger will require a special washout assembly design.

2. PRODUCTS

- A. Base Course: Untreated base course, APWA Section 32 11 23. Do not use gravel as a base course without ENGINEER's permission.
- B. Backfill: Common fill, APWA Section 31 05 13. **BORROW** Maximum particle size **3**-inches.
- C. Concrete: Class 4000, APWA Section 03 30 04.

3. EXECUTION

- A. Pour concrete against undisturbed soil.
- B. Apply tape wrap to the exterior of all galvanized pipe per AWWA C209.
- C. Place plastic sheet at least 6 mils thick over drain gravel to prevent silting.
- D. After installation of washout valve assembly, verify the washout valve riser drains to gravel.
- E. Backfill and Base Course Placement: Maximum lift thickness is 8-inches before compaction. Compaction is 95 percent or greater of a modified proctor density, APWA Section 31 23 26.

Nibley City Amendments:

- 1. Not allowed. Install a fire hydrant assembly if fire flows are sufficient.**
- 2. For installations with insufficient fire flows, install a blow Off/Flushing Hydrant.**
- 3. See the Nibley City Approved Materials List (APL) for information on specific product types and manufactures**

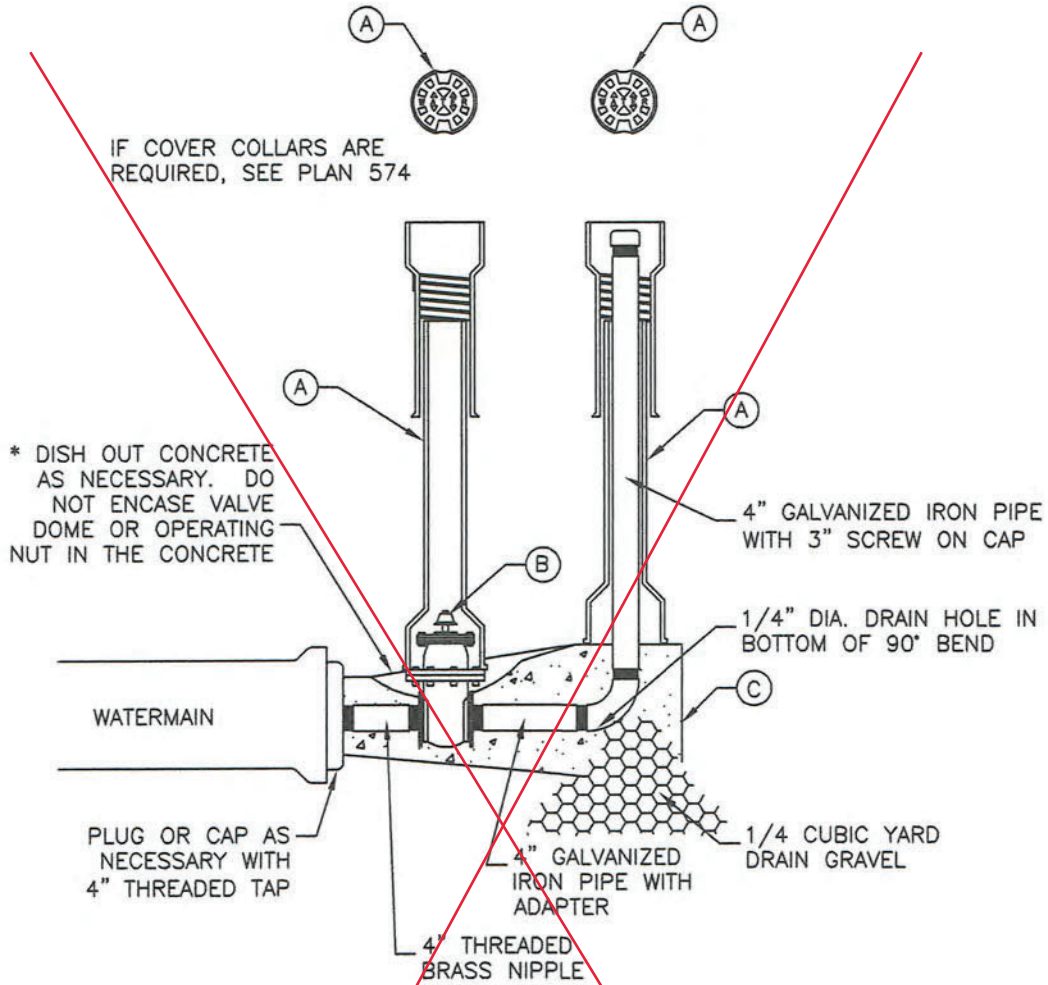

LEGEND		
No.	ITEM	DESCRIPTION
(A)	VALVE BOX WITH LID	2 PIECE CAST IRON
(B)	4" GATE VALVE WITH SCREW ENDS	2" x 2" OPERATING NUT
(C)	CONCRETE THRUST BLOCK	PLAN 561

Nibley City Amendments:

1. Not allowed. Install a temporary or permanent hydrant where washout valves would be needed.

Detector check valve with 3/4" bypass meter

1. GENERAL

- A. Configuration may be changed at ENGINEER's discretion.
- B. Additional requirements are specified in APWA Section 33 12 16.

2. PRODUCTS

- A. Blocking: Clay brick or concrete block.
- B. Small Fittings: Brass. Do not use galvanized materials.
- C. Grade Ring: 6-inch concrete grade ring required in roadways, Plan 361.
- D. Spools: Length of flange x plain end spool vary.

SPOOLS	
Pipe Size	Pipe Length
6"	10"
8"	8 1/4"
10"	6"

3. EXECUTION

- A. Install control valve with valve box adjacent to main.
- B. Concrete Box: Allow 1-inch clearance around waterline where water line passes through concrete box wall. Seal opening with compressible seal. Center frame and cover over water meter.
- C. Valve Option: The valve in the box (item B legend) closest to the main, and the top section of the valve box (item J legend) may be eliminated at the discretion of the ENGINEER.

When required, backflow prevention devices shall be located above ground and within a climate controlled structure.

When required, backflow prevention devices shall be located above ground and within a climate controlled structure.

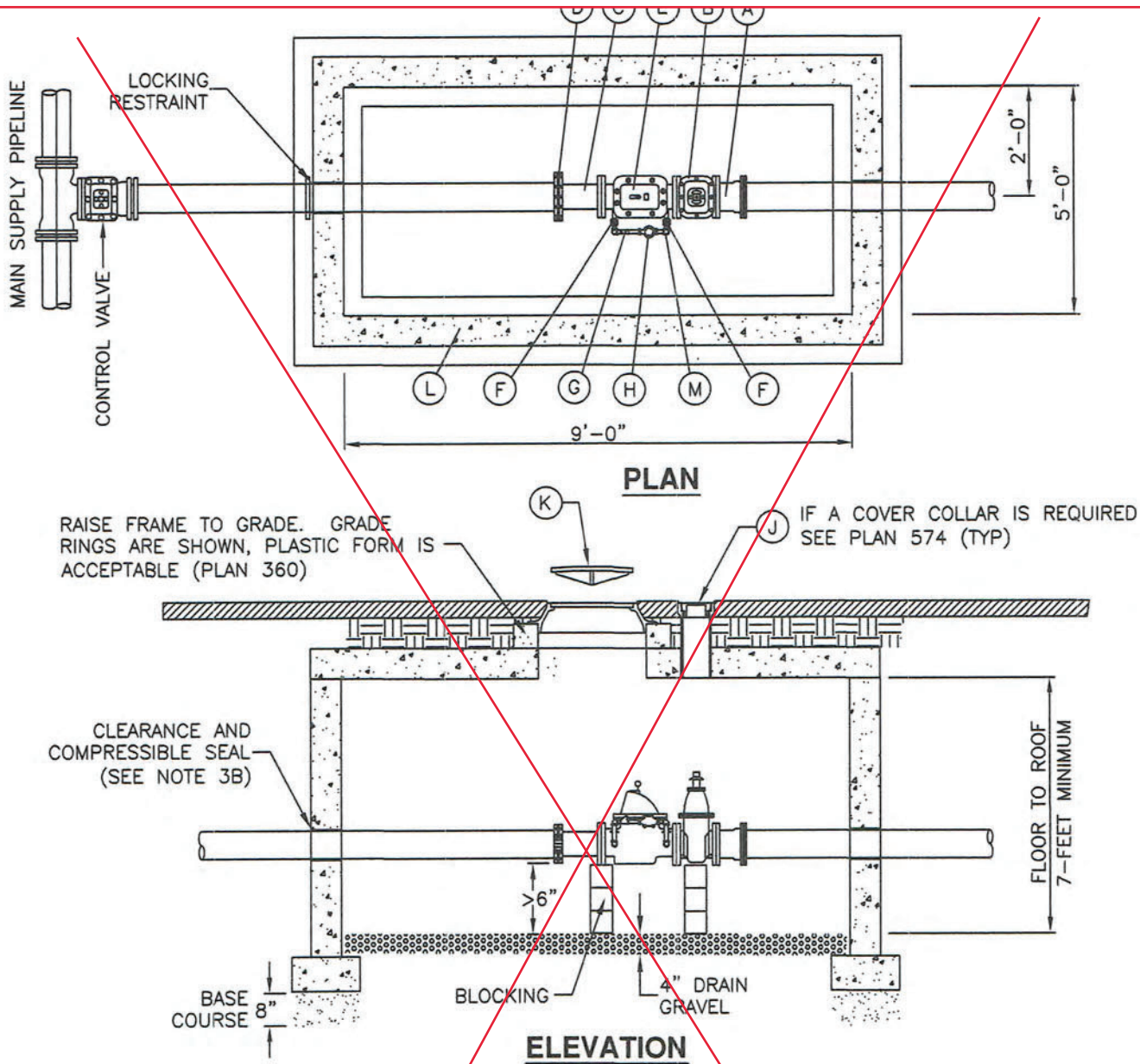

LEGEND			
No.	*	ITEM	DESCRIPTION
(A)		FLANGE AND M.J. ADAPTER	CEMENT LINED
(B)		GATE VALVE WITH 2"x2" OPERATOR NUT	EPOXY & CEMENT LINED
(C)		FLANGE x P.E. SPOOL	NOTE 3B
(D)		MECHANICAL JOINT AND FLANGE	
(E)		DETECTOR CHECK VALVE	EPOXY COATED
(F)		3/4" VALVE	EPOXY COATED
(G)		3/4" CHECK VALVE	EPOXY COATED
(H)		3/4" METER	EPOXY COATED
(J)		TOP SECTION OF VALVE BOX WITH LID	NOTE 3C
(K)		27" FRAME AND COVER	PLAN 502
(L)		CONCRETE BOX	PLAN 505
(M)		COPPER PIPING	TYPE L (RIGID)

* FURNISHED BY AGENCY

6" Pressure reducing valve with 2" bypass

1. GENERAL

- A. Configuration may be changed at ENGINEER's discretion.
- B. Additional requirements are specified in APWA Section 33 12 16.

2. PRODUCTS

- A. Small Fillings: Brass. Do not use galvanized materials.
- B. Blocking: Clay brick or concrete block.
- C. Taps: Provide two 3/4" I.P. taps with plugs for pressure gages.
- D. Drain Gravel: Sewer rock, ASTM size no. 3 (2" to 1") or equal, APWA Section 31 05 13.

3. EXECUTION

- A. Center frame and cover over water meter.
- B. Apply tape wrap to the exterior of all galvanized pipe per AWWA C209.
- C. Allow 1-inch clearance around waterline where water line passes through concrete box wall. Seal opening with compressible seal.

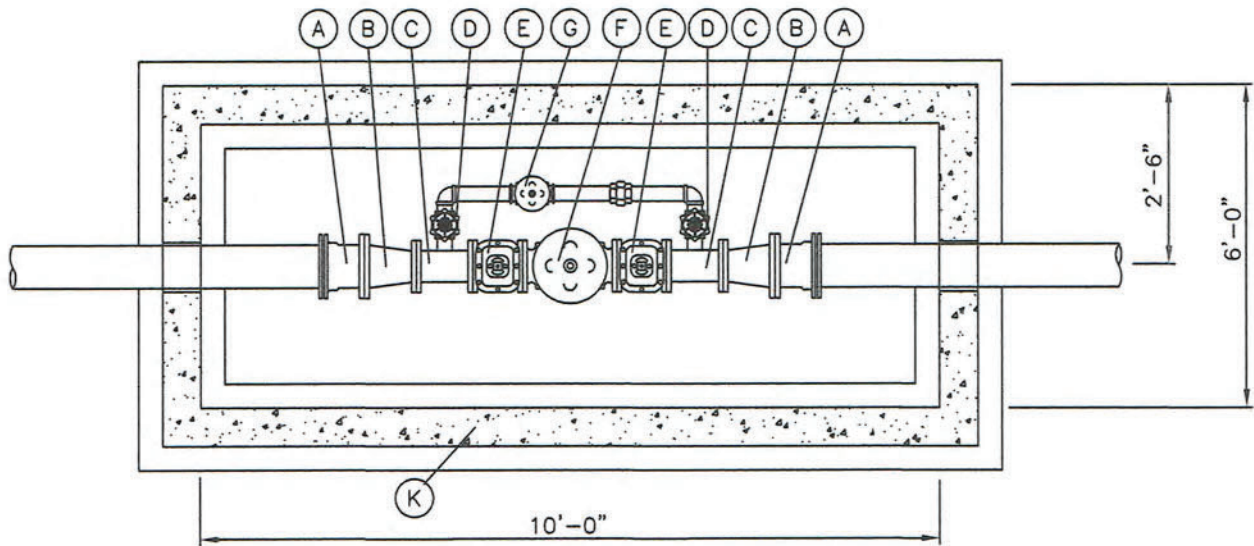

PLAN

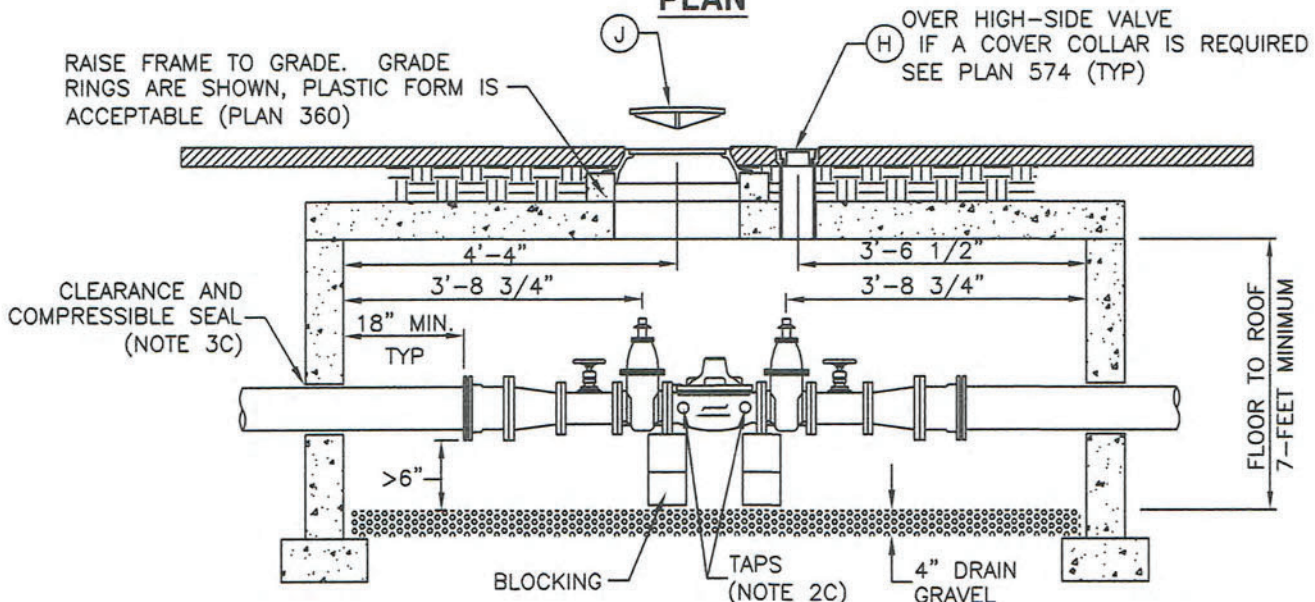

ELEVATION

LEGEND			
No.	*	ITEM	DESCRIPTION
(A)		8" M.J.x FLANGE ADAPTOR	CEMENT LINED
(B)		8" x 6" FLANGED REDUCER	CEMENT LINED
(C)		8" FLANGED STEEL SPOOL WITH 2" OUTLET	EPOXY COATED AND LINED
(D)		2" GATE VALVE	
(E)		6" GATE VALVE WITH 2"x2" OPERATING NUT	
(F)		6" PRESSURE REDUCING VALVE	
(G)		2" PRESSURE REDUCING VALVE	
(J)		27" FRAME AND COVER ← 38"	PLAN 502 503
(H)		TOP SECTION OF VALVE BOX WITH LID	
(K)		CONCRETE BOX	PLAN 505

* FURNISHED BY AGENCY

Cover collar for water valve box

1. GENERAL

A. In a pavement surface, fill an annular space around a frame and cover casting with concrete. The concrete will support the casting under traffic loadings.

2. PRODUCTS

A. Base Course: Untreated base course, APWA Section 32 11 23. Do not use gravel as a base course without ENGINEER's permission.

B. Concrete: Class 4000, APWA Section 03 30 04.

C. Concrete Curing Agent: Type ID Class A (clear with fugitive dye), membrane forming compound, APWA Section 03 39 00.

D. Use High Early Strength Fiber Mix to UDOT Standard- LeGrand Johnson (UDOT 70-B Mix) or Parson's (AA-AE HP) with mesh additive or equivalent.

3. EXECUTION

A. Base Course: Maximum lift thickness is 8-inches before compaction. Compaction is 95 percent or greater relative to a modified proctor density, APWA Section 31 23 26.

B. Pavement Preparation: Provide a neat vertical and concentric joint between concrete collar and existing bituminous concrete surface. Clean edges of all dirt, oil, and loose debris.

Nibley City Amendments:

1. Install tracer wire along the main and services accessible at valve box.

2. See the Nibley City Approved Materials List (APL) for information on specific product types and manufactures.

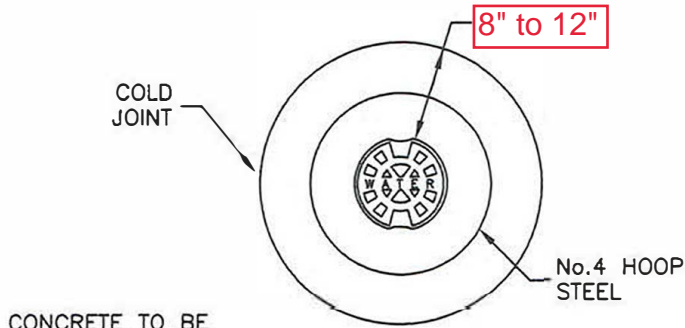

CONCRETE TO BE SET 1/2" MIN. TO 1/2" MAX. BELOW PAVEMENT LIP ALL AROUND

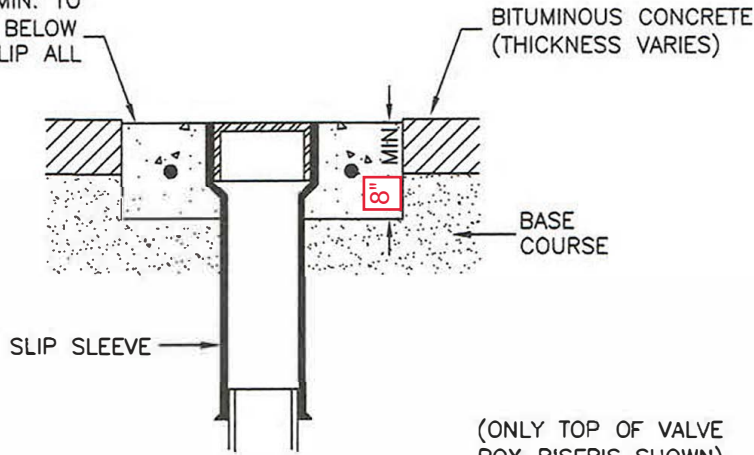

BITUMINOUS PAVEMENT

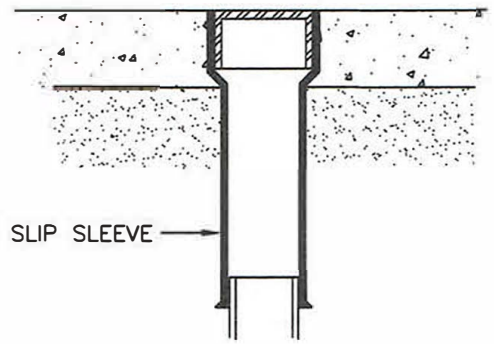

PORTLAND CEMENT CONCRETE PAVEMENT

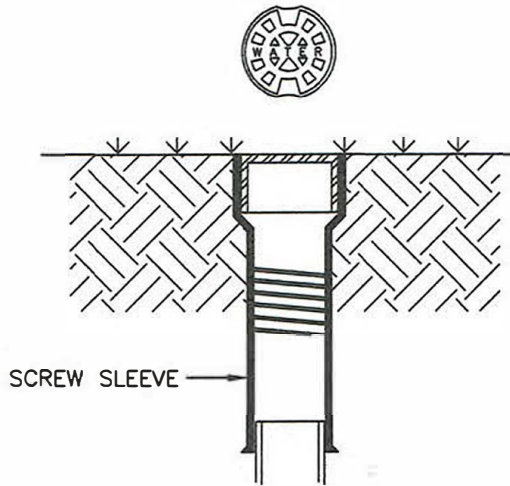

LANDSCAPED AREA

Nibley City Amendments:

1. Install tracer wire along the main and services accessible at valve box.
2. See the Nibley City Approved Materials List (APL) for information on specific product types and manufactures.
3. Valve Cans are not required on 2" services.

Air release assembly

1. GENERAL

- A. This drawing detail is applicable to water main piping less than 16-inches diameter.
- B. PCCP, steel, MLAC and other water main pipe materials will require special detail or design drawings. Submit the design and detail drawings and materials to the ENGINEER for review before installation.
- C. Installation in areas of high ground water or potential for water entering the vent pipe will require a special design to be provided by the ENGINEER.
- D. Before backfilling around the assembly, secure inspection of installation by ENGINEER.

2. PRODUCTS

- A. Base Course: Untreated base course, APWA Section 32 11 23. Do not use gravel as a base course without ENGINEER's permission.
- B. Drain Gravel: Sewer rock, ASTM size no. 3 (2" to 1") or equal, APWA Section 31 05 13.
- C. Backfill: Common fill, APWA Section 31 05 13. Maximum particle size 2-inches.
- D. Concrete: Class 4000, APWA Section 03 30 04.
- E. Manhole: Riser, ASTM C478.
- F. Reinforcement: Deformed, steel, ASTM A615. Give bars an epoxy coating at least 15 mils thick. Minimum stress yield strength of steel tie-down bars is 70,000 ksi.
- G. Small Fittings: Brass. Do not use galvanized materials.
- H. PVC Pipe and Fittings: Schedule 40, APWA Section 33 05 07.
- I. Water Tight Wall Seal: Waterproof, compressible.

3. EXECUTION

- A. Base Course and Backfill Placement: Maximum lift thickness is 8-inches before compaction. Compaction is 95 percent or greater relative to a modified proctor density, APWA Section 31 23 26.
- B. Apply tape wrap to the exterior of all buried steel pipe per AWWA C209.
- C. Concrete Placement: APWA Section 03 30 10. Provide 1/2-inch radius edges. Apply a broom finish. Apply a curing agent.
- D. Service saddle is required on all PVC and AC pipe taps unless specified otherwise. Ductile iron and cast iron pipe may be direct tapped.
- E. Seal manhole joints water-tight and ground flush with interior wall.
- F. Follow applicable AWWA and NSF standards when connecting piping.
- G. If diameter of air relief valve is greater than 2-inches, provide piping to match its diameter from water main connection to open to air.

Nibley City Amendments:

- 1. Install tracer wire along the main and services accessible at vault lid.
- 2. See the Nibley City Approved Materials List (APL) for information on specific product types and manufactures.

Pressurized irrigation water and potable water interface

1. GENERAL

- A. The catch basin valve and pump size must match the minimum discharge rate from the potable water system when indoor demands are also being expected from the system.

2. PRODUCTS

- A. All parts of the potable water system from the stop and waste valve to the air gap drop leg above the catch basin are to be copper or galvanized iron only.
- B. Below ground parts on the non-potable water system may be made of PVC or polyethylene at the agency's discretion.

3. EXECUTION

- A. Air gap. An air gap of at least two pipe diameters must exist between the maximum overflow lip of the catch basin and the end of the down-turned discharge pipe.
- B. Stop and Waste Valve: Locate the valve in an area where subsurface ground water will not accumulate or attach a drain pipe to the drain hole and drain to daylight with a non-corrodible #14 mesh screen over the end.
- C. Catch Basin: The ground surrounding the catch basin must slope away from the catch basin (basin cannot be located where flooding could result in a water level higher than the maximum overflow lip of the catch basin).
- D. Stand Pipes: Provide draining and freeze protection.
- E. Solenoid Valve: A solenoid operated valve may be installed at this point provided the valve and housing are not constructed of plastic (must be brass or ferrous metal).
- F. Galvanized Pipe: Apply tape wrap to the exterior of all galvanized pipe per AWWA C209.

Not Used
Provide "Swing Connection"

TYPE A - PUMP INTERCONNECT

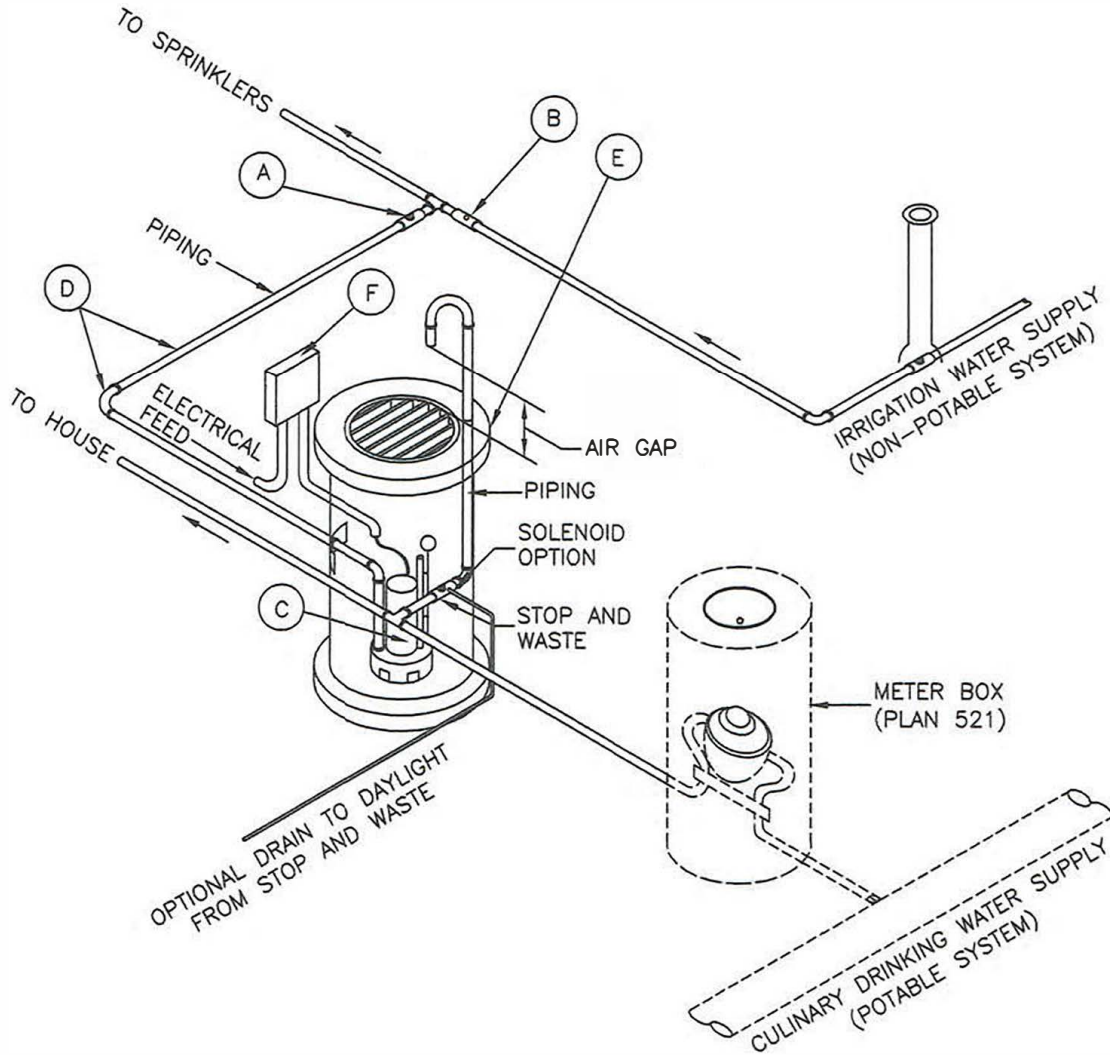

LEGEND		
No.	ITEM	DESCRIPTION
(A)	CONTROL VALVE	NOTE 1A
(B)	CHECK VALVE	SIZE TO MATCH EXISTING PIPE
(C)	SUBMERSIBLE PUMP WITH FLOAT OPERATED CUT-OUT SWITCH	NOTE 1A
(D)	ELBOWS, TEES & PIPE AS REQ'D	SCREWED OR FLANGED (OR BRAZED ABOVE GROUND ONLY)
(E)	CATCH BASIN	NOTE 1A
(F)	ELECTRICAL BOX AND CONDUIT	PER ELECTRICAL CODE

Pressurized irrigation water and potable water interface

1. GENERAL

- A. There may be up to 20 psi loss of head through the reduced pressure backflow preventer (RPBP) device. This is normal and the agency should expect a decrease in area coverage. Agency should design or modify the system for the lower pressure.

2. PRODUCTS

- A. Piping Materials.
 - 1) All above ground parts are to be copper or galvanized iron only.
 - 2) Below ground parts on the non-potable water system may be made of PVC or polyethylene at the agency's discretion.
- B. Cam Lock Fittings: Provide 3/4" long male insert attached to the flexible hose.

3. EXECUTION

- A. Separate Systems: Connect hose to only one system at a time. The other system is to remain separate. Do not direct connect potable and non-potable water systems with or without backflow prevention devices.
- B. Stop and Waste Valve: Locate the valve in an area where subsurface ground water will not accumulate, or attach a drain pipe to the drain hole and drain to daylight with a non-corrodible #14 mesh screen over the end.
- C. Testing: The RPBP device requires testing within 10 days of initial installation by a licensed backflow device tester and annually thereafter or more frequently at agency's option and expense.
- D. Backflow Preventer: Install the RPBP device above ground per the plumbing code. It must not be susceptible to flooding and must be accessible at all times for testing, repair, inspection, etc.
- E. Stand Pipes: Provide draining and freeze protection.
- F. Galvanized Pipe: Apply tape wrap to the exterior of all galvanized pipe per AWWA C209.

TYPE B- BACKFLOW PREVENTER INTERCONNECT

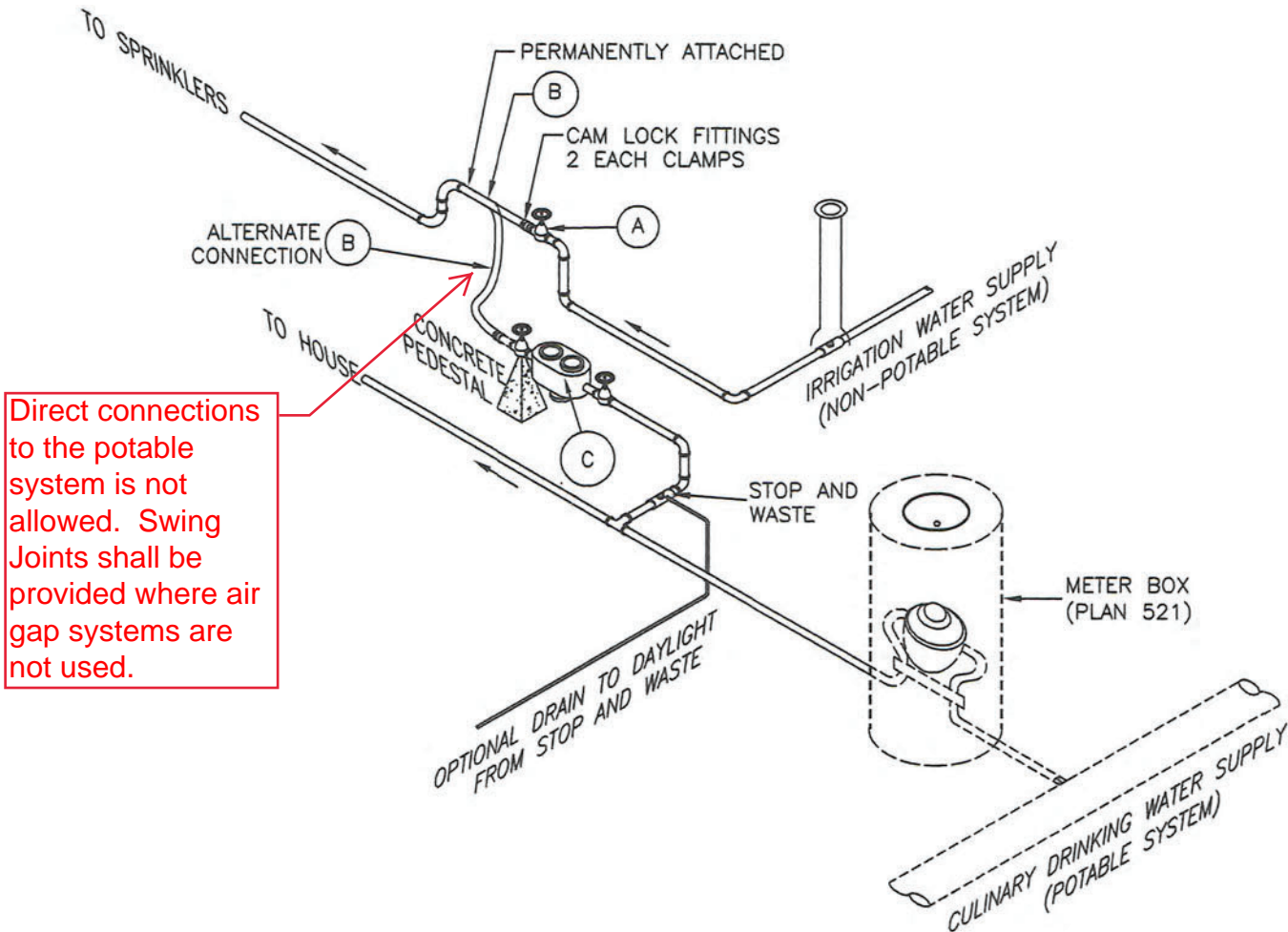

Direct connections to the potable system is not allowed. Swing Joints shall be provided where air gap systems are not used.

LEGEND		
No.	ITEM	DESCRIPTION
(A)	VALVE	BALL, RESILIENT SEAT, GATE OR ACCEPTABLE ALTERNATE
(B)	FLEXIBLE DISCHARGE HOSE	100 PSI WORKING PRESSURE 400 PSI BUST PRESSURE
(C)	REDUCED PRESSURE BACK-FLOW PREVENTER (RPBP) DEVICE	SHUTOFF VALVES & TEST COCKS ARE INCLUDED
(D)	ELBOWS AND TEES	SCREWED, FLANGED, (OR BRAZED ABOVE GROUND ONLY)

16.2 Sewer Details

Abbreviations and symbols for sewer

1. GENERAL

- A. Lettering Size: 10 point at final production.
- B. Lettering Style. Capital letters preferred.
- C. Existing Improvements. Shown in light shaded dashed line.
- D. New Improvements. Shown in solid continuous line.

2. PRODUCTS (Not used)

3. EXECUTION (Not used)

SYMBOLS	DEFINITIONS
	CENTER LINE
	CONSTRUCTION CENTER LINE
	PROPERTY OR R/W LINE
	EASEMENT LINE
	MONUMENT LINE
	FENCE
	CONTOUR LINE
	CONTOUR ELEVATION
	BANK SLOPES
	STORM DRAIN LINE
	WATER LINE
	GAS LINE
	TELEPHONE CABLE
	ELECTRIC CABLE
	SANITARY SEWER LINE
	ASPHALT PAVING
	FIRE HYDRANT
	WATER VALVE
	WATER METER
	MANHOLE
	CATCH BASIN
	CLEANOUT BOX
	POLE AND ANCHOR
	STREET LIGHT
	UNDISTURBED EARTH
	STRUCTURE

SYMBOLS	DEFINITIONS
	CURB & GUTTER
	SIDEWALK
	RAILROAD TRACKS
	GUARD RAIL
	OPEN DITCH, CANAL
	CULVERT
	SECTION CORNER
	SOIL BORING
	MONUMENT
	BM NO. 46 ELEV. 4256.50
	SIGN
	POWER POLE
	TELEPHONE POLE
	DECIDUOUS TREE
	CONIFEROUS TREE
	P.I.
	P.C. OR P.T.
<u>PROFILE</u>	
	GROUND PROFILE
	ROUND ARCH BOX CULVERT
	P.V.I.
	P.V.C. OR P.V.T.
	GROUND WATER ELEVATION

NOTE:

EXISTING FACILITIES MAY BE SHOWN IN SCREENED OR DASHED LINES

30" Frame and cover

1. GENERAL

A. The frame and cover fits the manhole in Plan 411.

2. PRODUCTS

A. Castings: Grey iron class 35 minimum, ASTM A48, coated with asphalt based paint or better (except on machined surfaces).

1) Cast the heat number on the frame and cover.

2) Give the frame and cover a machine finish so the cover will not rock.

3) √ designates machined surface.

4) Cast the words "SEWER" on the cover in upper case flush with the surface finish.

Provide locking manhole covers or watertight manhole covers as identified by the City Engineer. Generally these are required in areas such as undeveloped areas, sidewalks, trails and other walking surfaces.

3. EXECUTION

A. ~~Except in paved streets, provide locking manhole covers in~~ easements, alleys, parking lots, and all other places. Drill and tap two holes to a depth of 1-inch at 90 degrees to pry hole and install 3/4 x 3/4-inch allen socket set screws.

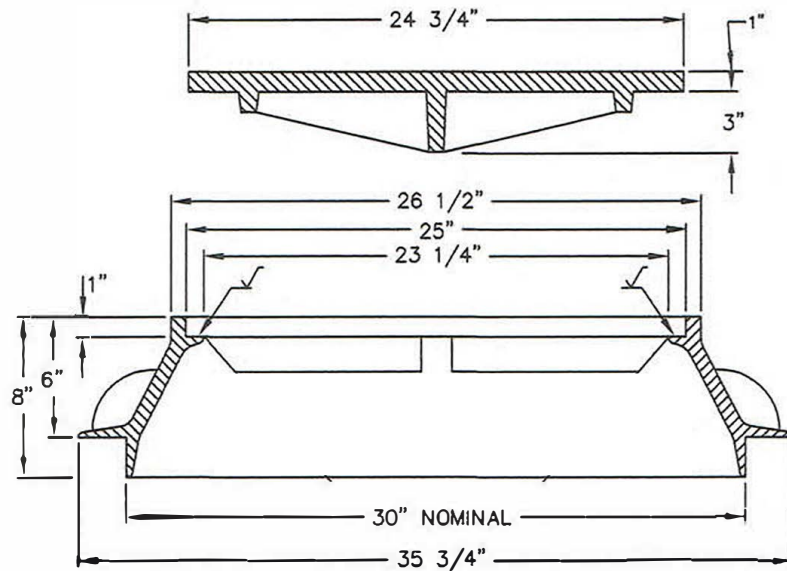
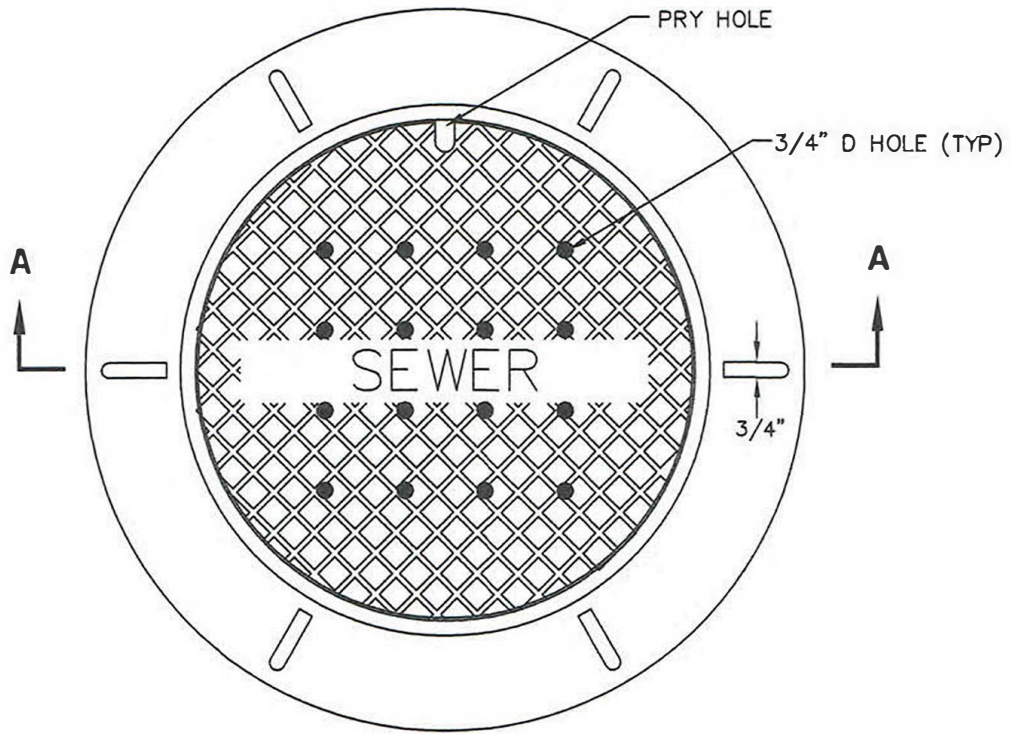

SECTION A-A

Sanitary sewer manhole

1. GENERAL

- A. The drawing shows typical pipe connections. Refer to construction drawings for connection locations or refer to field location of existing piping when engineering pipe connection to the manhole.
- B. Manhole size.
 - 1) Diameter is 4 feet: For sewers under 12" diameter.
 - 2) Diameter is 5 feet: For sewers 12" and larger, or when 3 or more pipes intersect the manhole or manholes that receive force main discharges.

2. PRODUCTS

- A. Base Course: Untreated base course, APWA Section 32 11 23. Do not use gravel as a base course without ENGINEER's permission.
- B. Backfill: Common fill, APWA Section 31 05 13. **BORROW** Maximum particle size 3-inches.
- C. Concrete: Class 4000, APWA Section 03 30 04.
- D. Riser and Reducing Riser: ASTM C478.
- E. Reinforcement: Deformed, 60 ksi yield grade steel, ASTM A615.
- F. Grout: 2 parts sand to 1 part cement mortar, ASTM C1329 **with hydrophilic additive (water stop).**
- G. Stabilization-Separation Geotextile: Moderate or high at CONTRACTOR's choice, APWA Section 31 05 19.
- J. **Exterior joint seal: Manhole Exterior Joint Mastic Seal. See Approved Materials List Sewer**

Manholes receiving discharge from forced main sewers shall be constructed with anchored HDPE liner. See Approved Materials List Sewer Collections

3. EXECUTION

- A. Foundation Stabilization: Get ENGINEER's permission to use a sewer rock or a granular backfill borrow in a geotextile wrap to stabilize an unstable foundation.
- B. Base Course Placement: APWA Section 32 11 23. Maximum lift thickness is 8-inches before compaction. Compaction is 95 percent or greater relative to a modified proctor density, APWA Section 31 23 26.
- C. Invert Cover. During construction, place invert covers over the top of pipe in manholes that currently convey sewerage. See Plan 412.
- D. Pipe Connections: Grout around all pipe openings **with hydrophilic additive (water stop).**
- E. Pipe Seal. ~~Install rubber-based pipe seals on all plastic pipes when connecting plastic pipes to manholes. Hold water-stop in place with stainless steel bands.~~
- F. Joints: Place flexible gasket-type sealant in all riser joints. Finish with grout.
- G. Adjustment: If the required manhole adjustment is more than 1'-6", remove the cone and grade rings and adjust the manhole elevation with the appropriate manhole section, the cone section, and ~~the grade rings or~~ plastic form to make frame and lid match finish grade.
- H. Finish: Provide smooth and neat finishes on interior of cones, shafts, and rings. Imperfect moldings or honeycombs will not be accepted.
- I. Backfill: Provide backfill against the manhole shaft. Pea gravel and recycled RAP aggregate is NOT ALLOWED. Water jetting is NOT allowed. Maximum lift thickness is 8-inches before compaction. Compaction is 95 percent or greater relative to a standard proctor density, APWA Section 31 23 26.
- J. **Manholes located in undeveloped or landscaped areas subject to flooding or irrigation must be installed at least 18-inches higher than finished ground elevation. The manhole shall be provided with a water tight solid locking or bolted manhole cover.**

**2-layers
of KENT
Seal**

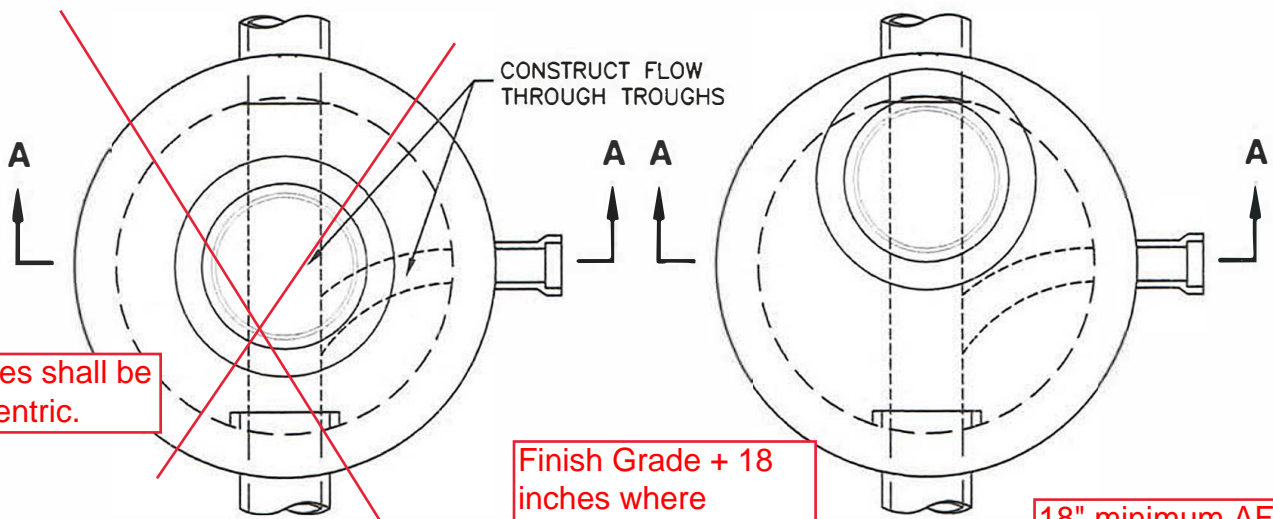

Cones shall be Eccentric.

Finish Grade + 18 inches where located in undeveloped areas subject to flooding or irrigation.

18" minimum AFG. Use solid 18" riser section and with water tight joints, lid and frame

Provide ladder access

PLAN
(CONCENTRIC RISER)

PLAN
(ECCENTRIC RISER)

CONCRETE COLLAR (PLAN 413)
FRAME AND COVER (PLAN 402)
FINISH GRADE

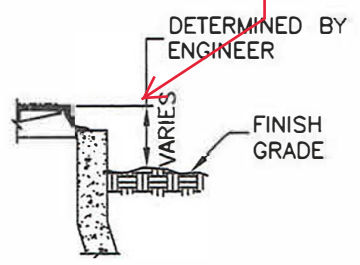

WHIRLYGIG MANHOLE RISER COLLAR SYSTEM (or equal) or plastic form as approved by Inspector

DETAIL
(UNIMPROVED AREAS)

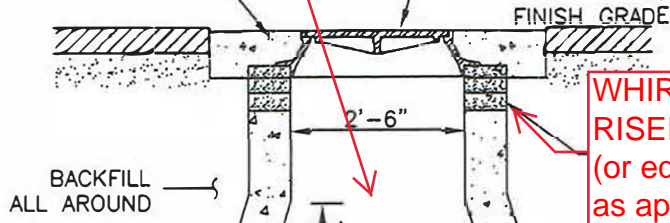

2 layers of Kent seal at each joint

Hydrophilic grout at pipe penetrations

External Joint Mastic Seal at exterior of each joint.

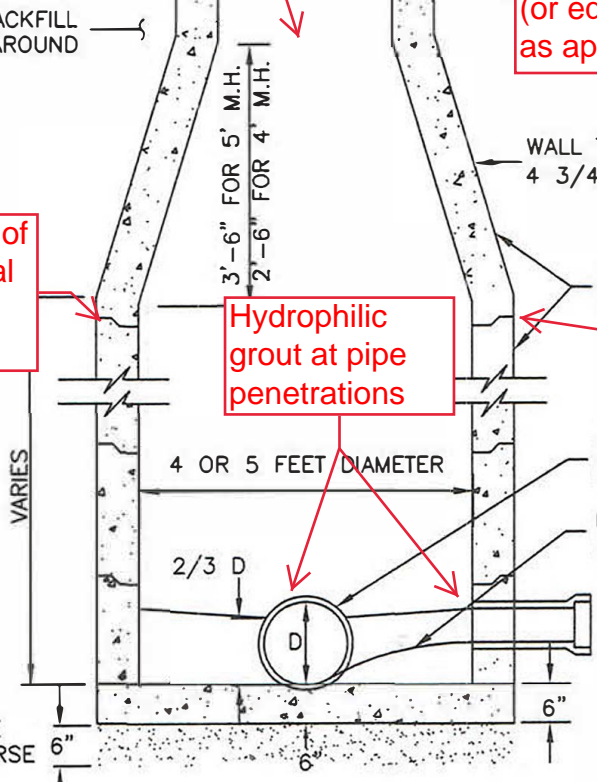

SECTION A-A

Dog house style manholes are not allowed in areas with high water table without engineering design to prevent infiltration and leaking. Must have specific approval from City Engineer.

Cover collar for sanitary sewer manhole

1. GENERAL

A. In a pavement surface, the concrete will support the frame under traffic loadings.

2. PRODUCTS

A. Concrete: Class 4000, APWA Section 03 30 04.

B. Concrete Curing Agent: Type ID Class A (clear with fugitive dye), membrane forming compound, APWA Section 03 39 00.

C. Use High Early Strength Fiber Mix to UDOT Standard- LeGrand Johnson (UDOT 70-B Mix) or Parson's (AA-AE-HP) with mesh additive or equivalent.

3. EXECUTION

A. Pavement Preparation: Provide a neat vertical and concentric joint between the concrete collar and the bituminous pavement surface. Clean edges of all dirt, oil, and loose debris. Use WHIRLYGIG MANHOLE RISER COLLAR SYSTEM form and placement (or equal)

B. Concrete Placement: Fill the annular space around the frame and cover casting with concrete. Apply a broom finish. Apply a curing agent.

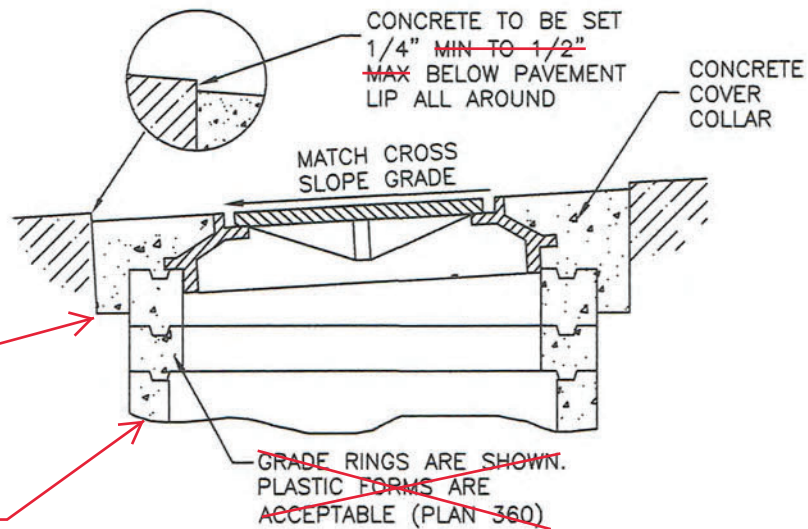
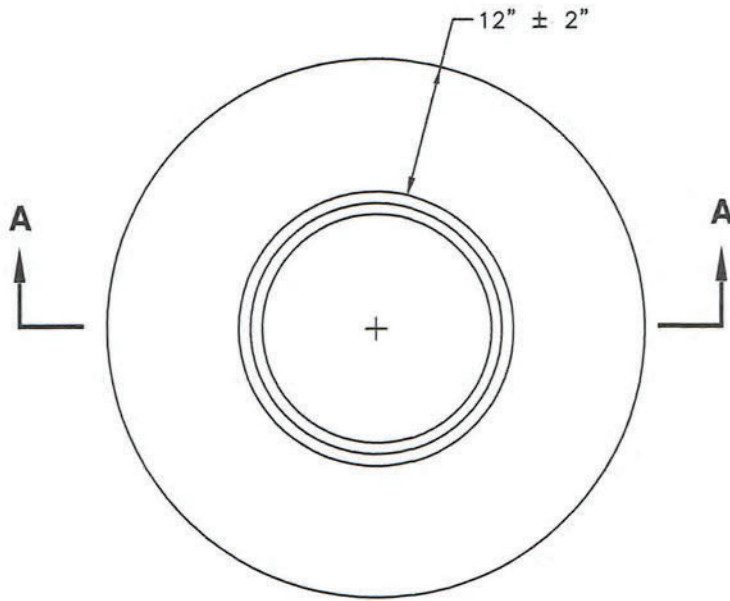

Min. 10" thick (typ)

WHIRLYGIG
MANHOLE RISER
COLLAR SYSTEM
(or equal)

SECTION A-A

Sewer lateral connection

1. GENERAL

- A. Before installation, secure acceptance by ENGINEER for all pipe, fittings, and couplings to be used.
- B. Before backfilling, secure inspection of installation by ENGINEER. Give at least 24 hours notice.
- C. Verify if CONTRACTOR or agency is to install the wye.

2. PRODUCTS

- A. Base Course: Untreated base course, APWA Section 32 11 23. Do not use gravel as a base course ~~without ENGINEER's permission.~~
- B. Backfill: Common fill, APWA Section 31 05 13. **BORROW- 3-inch minus.**
- C. Provide agency approved wye or tee with appropriate donut.
- D. Stainless steel straps required.

3. EXECUTION

- A. Tape wrap pipe as required by soil conditions.
- B. Remove core plug from sewer main. Do not break into sewer main to make connection.
- C. Base Course and Backfill Placement: Maximum lift thickness is 8-inches before compaction. Compaction is 95 percent or greater relative to a standard proctor density, APWA Section 31 23 26.

Sewers and sewer laterals located within drinking water source protection zones shall comply with Utah R309-600

Locate within 2.5' of structure and as required by IPC or IRC

Threaded PVC cap

CAST IRON OR BRASS CLEAN OUT PLUG

Service Lateral approved PVC (SDR35) or HDPE (SDR26)

6" minimum Multi-family/ Commercial / Industrial

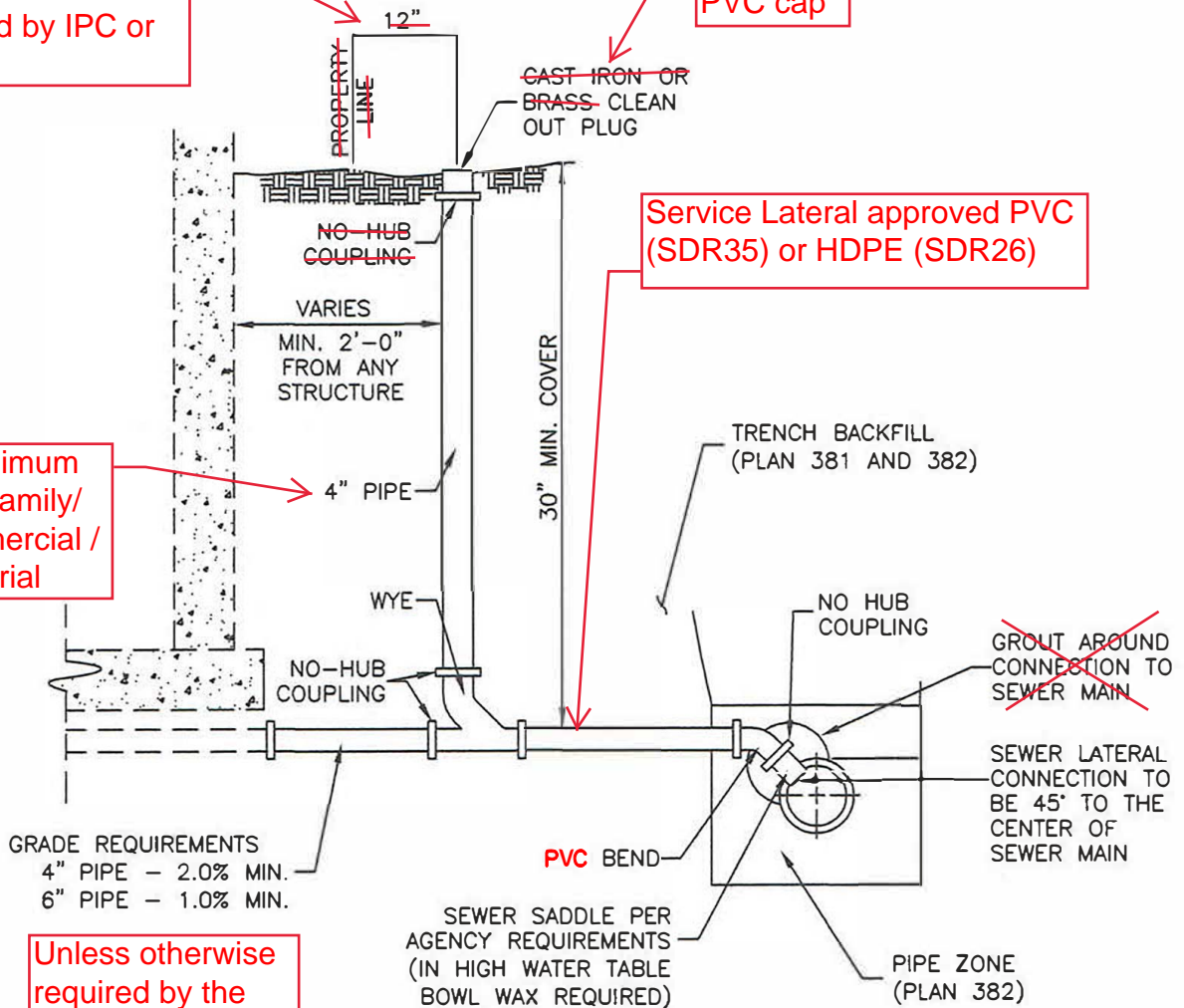

GRADE REQUIREMENTS
4" PIPE - 2.0% MIN.
6" PIPE - 1.0% MIN.

Unless otherwise required by the building code.

Wyes required for new sewer line construction. Saddles allowed for connecting to existing sewer lines.

Sewers and sewer laterals located within drinking water source protection zones shall comply with Utah R309-600

Sewer lateral relocation

1. GENERAL

- A. Before installation, secure acceptance by ENGINEER for all pipe, fittings, and couplings to be used.
- B. Before backfilling, secure inspection of installation by ENGINEER. Give at least 24 hours notice.
- C. Verify if CONTRACTOR or agency is to install the wye or donut.

2. PRODUCTS

- A. Base Course: Untreated base course, APWA Section 32 11 23. Do not use gravel as a base course ~~without ENGINEER's permission.~~
- B. Backfill: Common fill, APWA Section 31 05 13. **BORROW-** Maximum particle size **3**-inches.
- C. Provide agency approved wye or tee with appropriate donut.

3. EXECUTION

- A. ~~Tape wrap metal pipe and metal fittings.~~ Only PVC and HDPE allowed.
- B. Do not install couplings under the obstruction.
- C. Under the obstruction, loosely compact granular material or sand. Flowable fill not allowed.
- D. Base Course and Backfill Placement: Maximum lift thickness is 8-inches before compaction. Compaction is 95 percent or greater relative to a standard proctor density, APWA Section 31 23 26.

Sewers and sewer laterals located within drinking water source protection zones shall comply with Utah R309-600

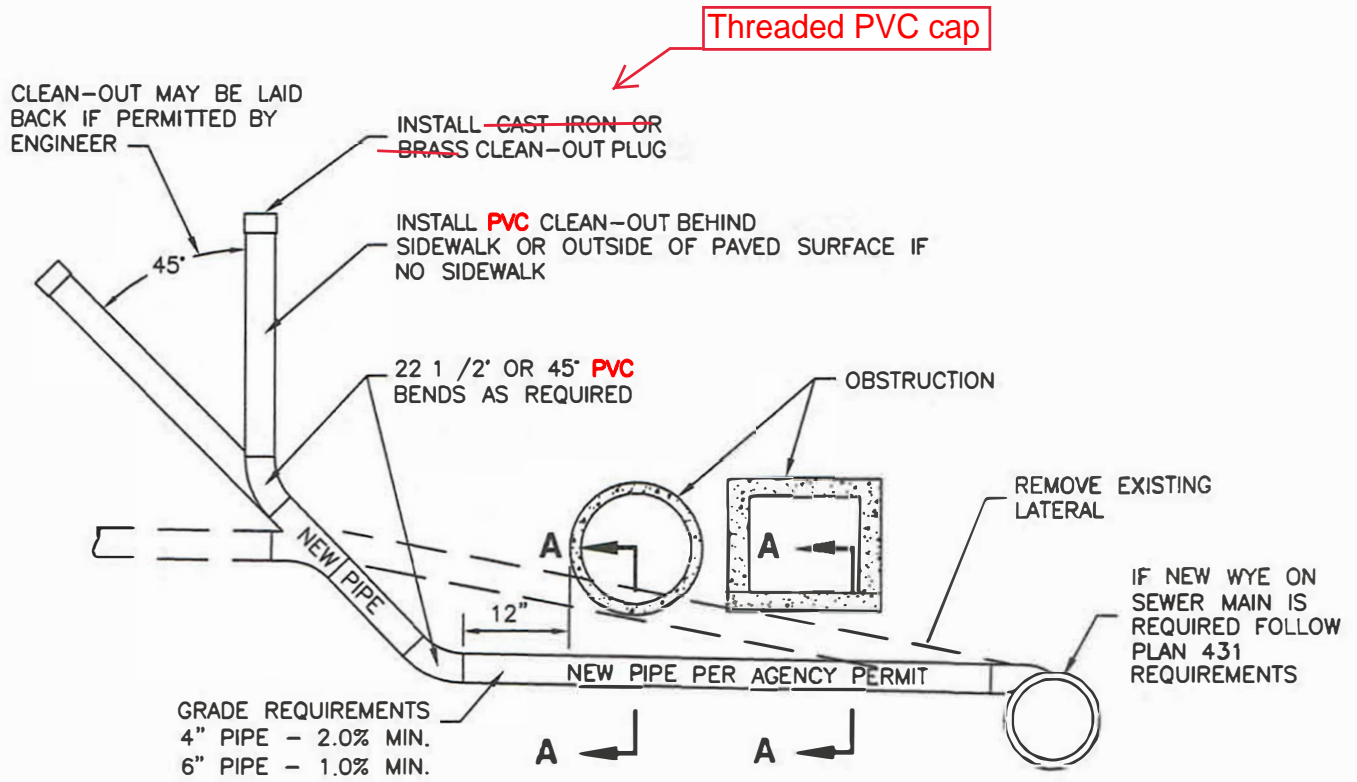

Threaded PVC cap

SECTION

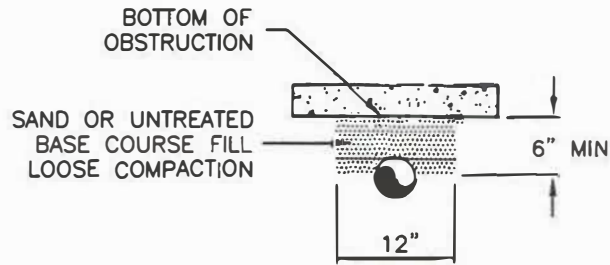

REPLACE EXISTING LATERAL PER AGENCY PERMIT

SECTION A-A

Sewers and sewer laterals located within drinking water source protection zones shall comply with Utah R309-600

Pipe drop / Force Main Manhole

1. GENERAL

- A. Only one drop pipe is allowed inside the manhole.
- B. Size of drop pipe is to be the same diameter as sewer mainline pipe that it serves.

2. PRODUCTS

- A. Concrete: Class 4000, APWA Section 03 30 04.
- B. Anchors: Use stainless steel anchors that are acceptable to ENGINEER.

3. EXECUTION

- A. At the match point, match the 3/4 diameter points of the pipes.
- B. If the drop is more than 18-inches, anchor the riser to the wall every 12-inches.
- C. Extend concrete encasement to first joint beyond excavation for drop connection.

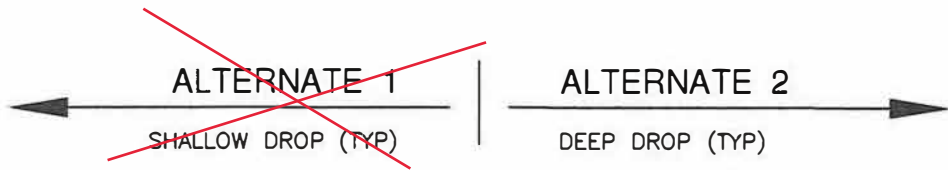
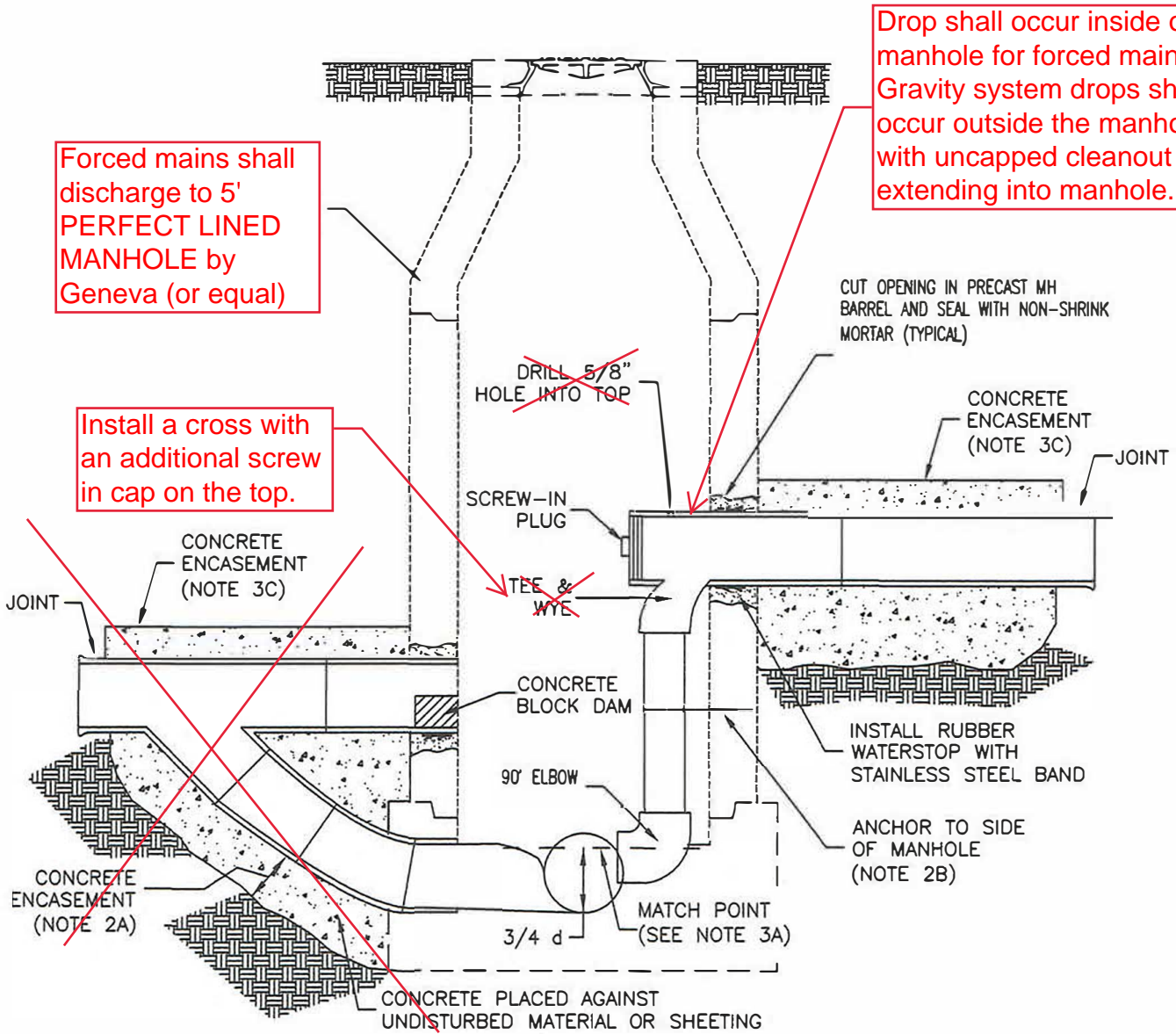

SECTION

Grease trap

1. GENERAL

- A. Before backfilling around concrete box, secure inspection of installation by ENGINEER.

2. PRODUCTS

- A. Base Course: Untreated base course, APWA Section 32 11 23. Do not use gravel as a base course without ENGINEER's permission.
- B. Backfill: Common fill, APWA Section 31 05 13. Maximum particle size 2-inches.
- C. Concrete: Class 4000, APWA Section 03 30 04.
- D. Reinforcement: Deformed, 60 ksi yield grade steel, ASTM A615.
- E. PVC Pipe: APWA Section 33 05 07.

3. EXECUTION

- A. Base Course Placement: APWA Section 32 11 23. Maximum lift thickness is 6-inches before compaction. Compaction is 95 percent or greater relative to a modified proctor density, APWA Section 31 23 26.
- B. Reinforcement Placement: APWA Section 03 20 00.
- C. Concrete Placement: APWA Section 03 30 10. Provide 1/2-inch radius edges. Apply a broom finish. Apply a curing agent.
- D. Fill annular space around pipe wall penetrations with waterproof sealer.
- E. Backfill: Provide backfill against the box walls. Pea gravel and recycled RAP aggregate is NOT ALLOWED. Water jetting is NOT allowed. Maximum lift thickness is 8-inches before compaction. Compaction is 95 percent or greater relative to a standard proctor density, APWA Section 31 23 26.

Grease traps and sand interceptors shall meet Logan City Pretreatment requirements. Contact 435-716-9797

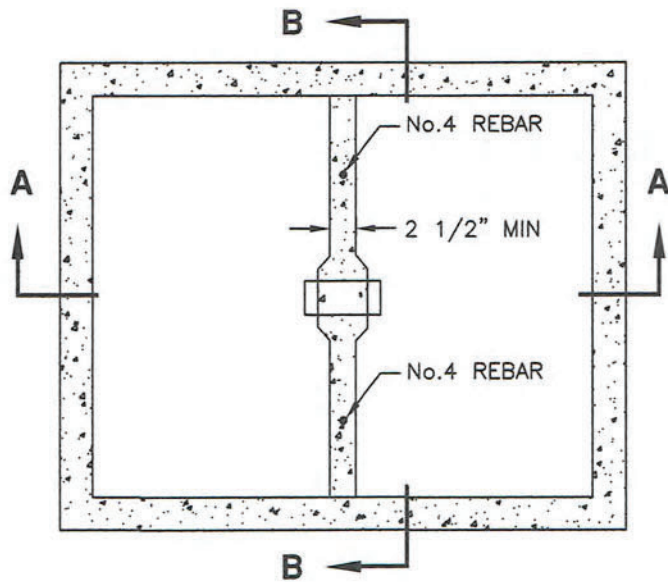

BOX PLAN

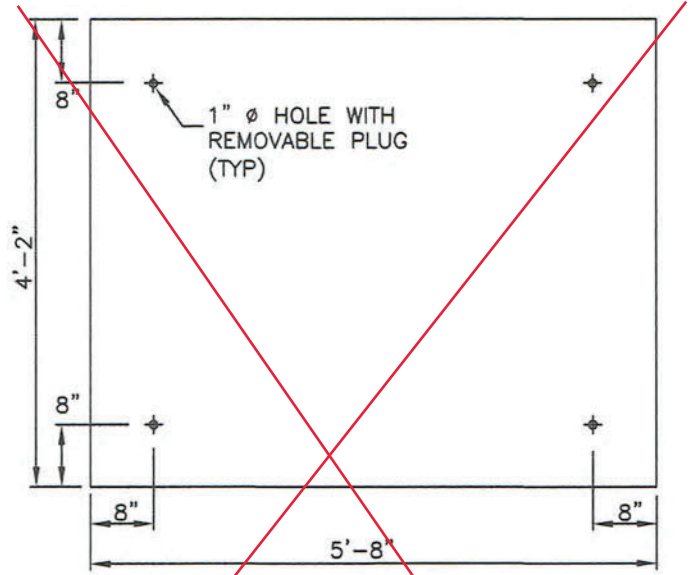

LID PLAN

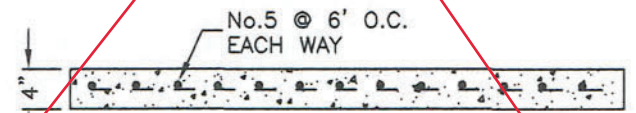

LID SECTION

The dimensions shown are minimum dimensions only. Larger grease traps or interceptors are required according to the application as determined by the Logan City Pretreatment Manager 435-716-9797.

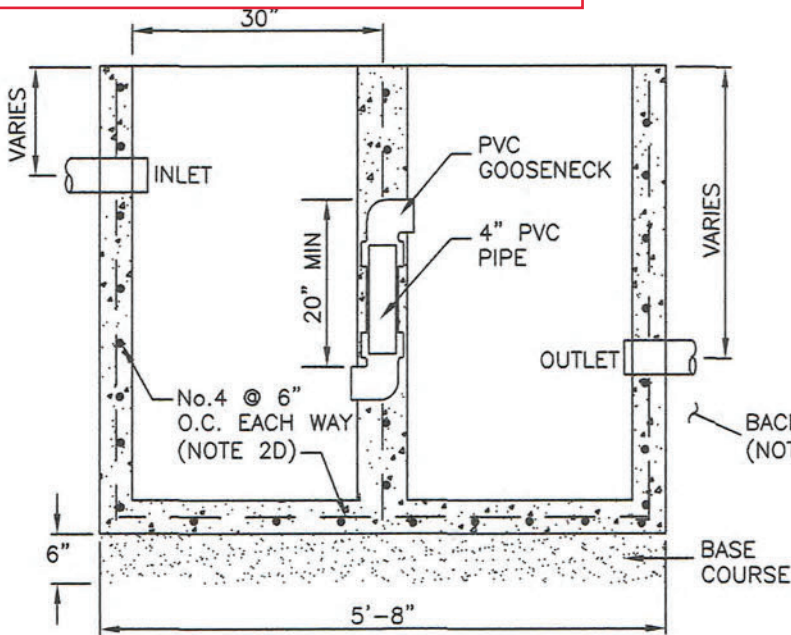

SECTION A-A

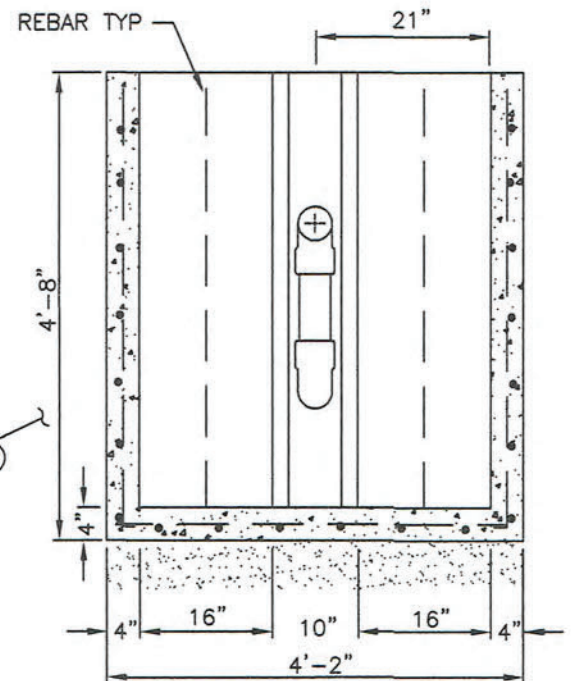

SECTION B-B

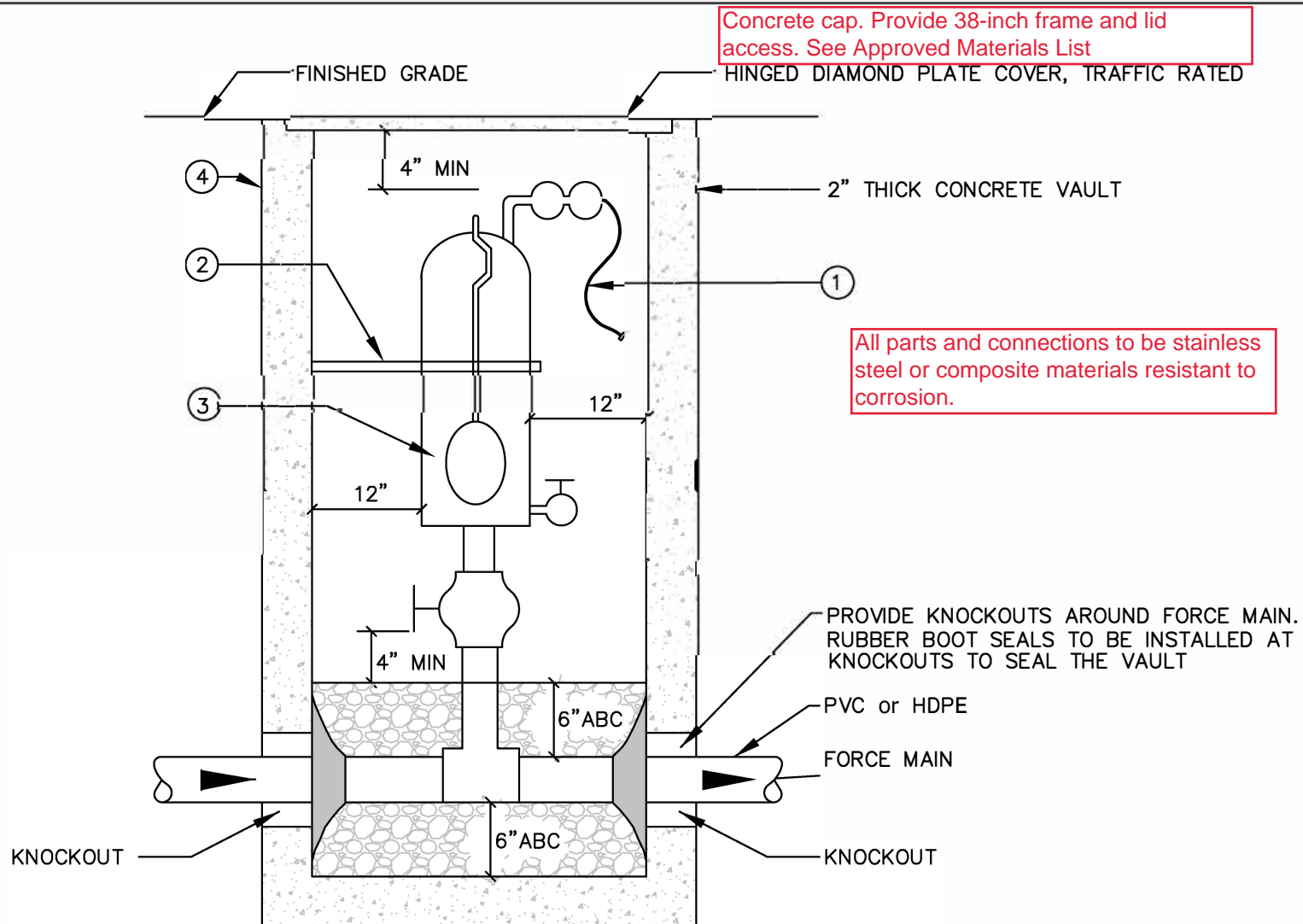

NOTES:

1. BLACK FLUSHING HOSE WITH QUICK COUPLER ATTACHED AT FREE END, 2 FEET IN LENGTH.
2. SUPPORT FOR AIR RELEASE VALVE.
3. SEWAGE AIR RELEASE VALVE.
4. ROTATE VAULT AS REQUIRED TO KEEP BEHIND BACK OF CURB.

DETAIL NO.

FORCE MAIN AIR RELEASE VALVE

DETAIL NO.

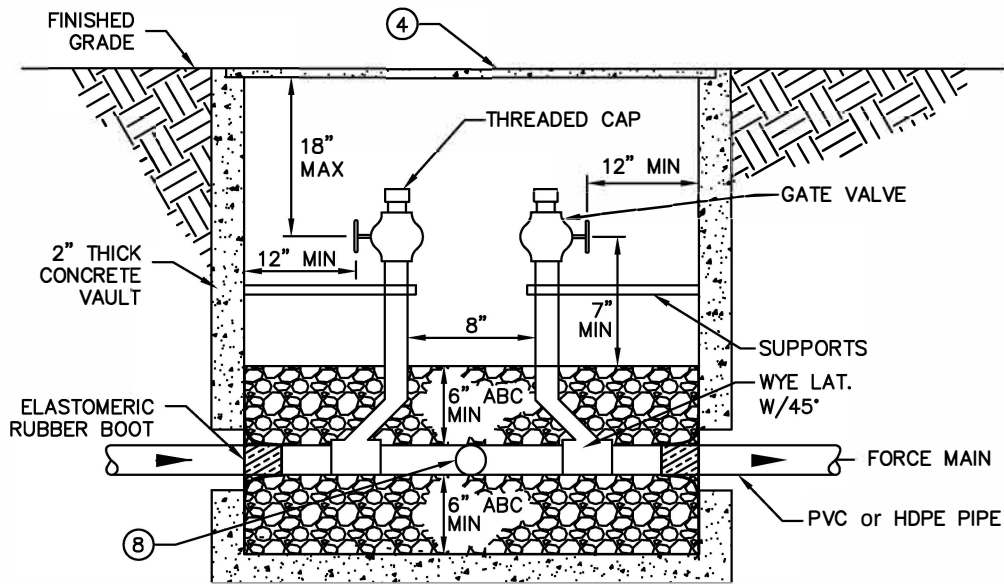
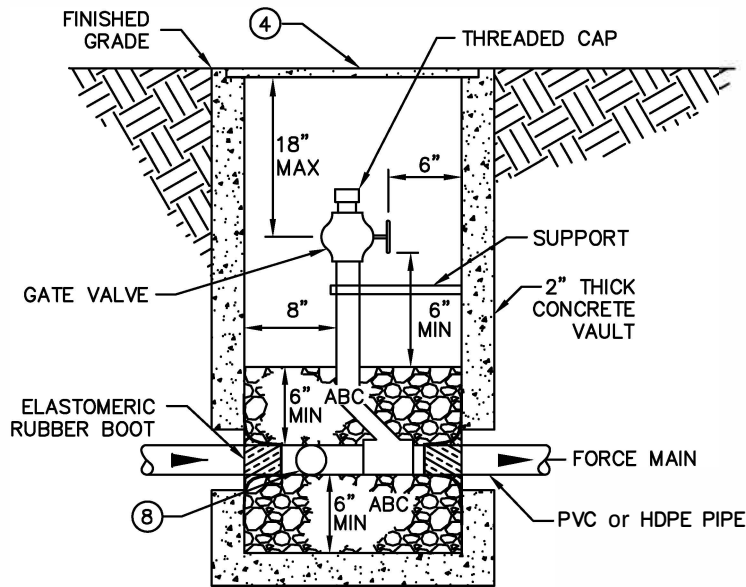

NOTES:

1. ONE-WAY CLEANOUTS SHALL BE INSTALLED ON MAXIMUM 400- FOOT CENTERS ALONG FORCE MAIN. ROTATE VAULT AS REQUIRED TO KEEP BEHIND BACK OF CURB.
2. TWO-WAY CLEANOUTS SHALL BE INSTALLED ON A MAXIMUM 800-FOOT CENTERS ALONG FORCE MAIN. ROTATE VAULT AS REQUIRED TO KEEP BEHIND BACK OF CURB.
3. AN AIR RELEASE VALVE SHALL BE INSTALLED ADJACENT TO ANY FORCE MAIN CLEANOUT.
4. DIAMOND PLATE COVER, TRAFFIC-RATED.
5. RISER PIPES TO BE SAME DIAMETER AS FORCE MAIN (PLUG END WITH THREADED CAP).
6. PROVIDE KNOCKOUTS AROUND FORCE MAIN. RUBBER BOOT SEALS TO BE INSTALLED AT KNOCKOUTS TO SEAL THE VAULT.
7. PROVIDE 12" ABC MATERIAL AROUND FORCE MAIN.
8. PROVIDE GATE VALVE FOR FORCE MAINS WITH DIAMETERS OF 2" OR LESS.
9. A MINIMUM 12" OF CLEARANCE SHALL BE MAINTAINED BETWEEN THE VAULT WALLS AND THE CLEANOUT EQUIPMENT.
10. FORCE MAINS SHALL BE A MINIMUM OF 5' DEEP

DETAIL NO.

FORCE MAIN CLEANOUTS

DETAIL NO.